

**POLE CANYON ANNEXATION AND MASTER
DEVELOPMENT AGREEMENT**

Dated: January 19, 2010

TABLE OF CONTENTS

| | | |
|------|-------------------------------------------------------------------------------------------------------------------|-----------|
| 1. | Conditions to Obligations | 5 |
| 1.1. | Annexation..... | 5 |
| 1.2. | Zoning | 6 |
| 2. | Pole Canyon Investment Group Representative..... | 6 |
| 3. | Development of the Project..... | 7 |
| 4. | Planning Areas; Development of the PCIG Property in Compliance with the Pole Canyon Master Development Plan. | 7 |
| 4.1. | Planning Areas Generally | 7 |
| 4.2. | Phasing | 8 |
| | 4.2.1. Arterial Road Corridor | 9 |
| 4.3. | Project Maximum Density..... | 9 |
| | 4.3.1. Density Transfer | 10 |
| 4.4. | Uses and Densities | 11 |
| 4.5. | Accounting for Density for Parcels Developed by the PCIG..... | 11 |
| 4.6. | Accounting for Density for Parcels Sold to Subdevelopers | 11 |
| | 4.6.1. Return of Unused Density | 12 |
| 5. | Zoning and Vested Rights..... | 12 |
| 5.1. | Vested Rights Granted by Approval of this Agreement | 12 |
| 5.2. | Term of Agreement..... | 13 |
| 6. | Approval Processes for Development Applications..... | 13 |
| 6.1. | Processing Under City's Code..... | 13 |
| 6.2. | City's Cooperation in Processing Development Applications | 14 |

| | | |
|-------|------------------------------------------------------------------------------------------|----|
| 6.3. | [Intentionally Omitted.] | 14 |
| 6.4. | Independent Technical Analyses for Development Applications..... | 14 |
| 6.5. | City Denial of a Development Application | 14 |
| 6.6. | Meet and Confer regarding Development Application Denials | 14 |
| 6.7. | City Denials of Development Applications Based on Denials from Non-City Agencies..... | 15 |
| 7. | [Intentionally Omitted.] | 15 |
| 8. | Open Space and Trails Requirements | 15 |
| 8.1. | Regional Parks | 15 |
| | 8.1.1. Lagoon Property..... | 16 |
| 8.2. | Rodeo Grounds | 17 |
| 8.3. | Interim Equestrian Facility | 18 |
| 8.4. | Creation of Open Space and/or Trails..... | 18 |
| 8.5. | Public Access to Open Space and/or Trails | 19 |
| 8.6. | Accounting for Open Space for Parcels Developed by the PCIG | 20 |
| 8.7. | Accounting for Open Space for Parcels Sold to Subdevelopers..... | 21 |
| | 8.7.1. Credit for Additional Open Space..... | 21 |
| 8.8. | Notice to City..... | 21 |
| 8.9. | Dedication of Open Space and/or Trails..... | 22 |
| 8.10. | Maintenance of Open Space and/or Trails..... | 22 |
| 8.11. | Tax Benefits | 23 |
| 9. | Infrastructure and Improvements..... | 23 |
| 9.1. | Design and Construction of Public Infrastructure and Improvements... | 23 |
| 9.2. | No Additional Off-Site Infrastructure Requirements | 24 |

| | | |
|--------|----------------------------------------------------------------------------|----|
| 9.3. | Pole Canyon Local District..... | 24 |
| 9.4. | Special Assessment Area | 25 |
| 9.4.1. | Establishment by City of SAAs for Certain Improvements..... | 26 |
| 9.4.2. | Fire Station..... | 27 |
| 9.4.3. | White Hills Park..... | 27 |
| 9.5. | Community Development Area / Economic Development Area | 28 |
| 9.6. | Capital Facilities Plan and Impact Fees..... | 28 |
| 9.6.1. | Preparation and Adoption of Capital Facilities Plan and Impact Fee..... | 28 |
| 9.7. | Construction Prior to Completion of Infrastructure..... | 29 |
| 10. | Cable TV/Fiber Optic Service | 29 |
| 11. | Enforcement of Technical Guidelines and CC&R's..... | 30 |
| 12. | Payment of Fees..... | 30 |
| 12.1. | General Requirement of Payment of Fees | 30 |
| 12.2. | Infrastructure Built by the PCIG..... | 30 |
| 12.3. | Reimbursement for "Upsizing"..... | 30 |
| 13. | Permits; Security for Improvements..... | 31 |
| 13.1. | Building Permits | 31 |
| 13.2. | City and Other Governmental Agency Permits | 31 |
| 13.3. | Security for Public Improvements | 32 |
| 13.4. | Separate Security for Landscaping | 32 |
| 14. | Dedication of Public Improvements | 32 |
| 15. | City's Obligations | 33 |
| 16. | Water. | 33 |

| | | |
|-------|------------------------------------------------------------------------------------------------|----|
| 16.1. | Generally..... | 33 |
| 16.2. | Transfer of Water Rights, Water Sources, Water Storage, and Water Distribution Systems..... | 34 |
| 16.3. | Additional Water Tank Property..... | 34 |
| 17. | Rocky Mountain Power | 35 |
| 18. | Additional Easements | 35 |
| 19. | Agricultural and Agricultural Related Uses of Master Planned Area..... | 36 |
| 19.1. | Generally..... | 36 |
| 19.2. | Agricultural Use Prior to Development | 36 |
| 20. | On-Site Processing of Natural Materials | 37 |
| 21. | Future Property Which May be Included in this Agreement | 38 |
| 21.1. | Future Property within the Master Planned Area | 38 |
| 21.2. | Future Property not within the Master Planned Area | 38 |
| 22. | Special Conditions. | 38 |
| 22.1. | WHSSD Agreement..... | 38 |
| 22.2. | WHWC Transition Agreement | 39 |
| 22.3. | Local District Agreement..... | 39 |
| 23. | Default. | 40 |
| 23.1. | Notice..... | 40 |
| 23.2. | Contents of the Notice of Default | 40 |
| 23.3. | Remedies..... | 40 |
| 23.4. | Notice and Public Meeting..... | 41 |
| 23.5. | Emergency Defaults..... | 41 |
| 23.6. | Extended Cure Period | 42 |

| | | |
|--------|-------------------------------------------|----|
| 24. | Amendment..... | 42 |
| 25. | Assignability | 42 |
| 26. | Miscellaneous | 42 |
| 26.1. | Incorporation of Recitals, Exhibits | 42 |
| 26.2. | Binding Effect..... | 42 |
| 26.3. | Notices | 43 |
| 26.4. | Headings | 43 |
| 26.5. | Integration..... | 43 |
| 26.6. | Severability | 43 |
| 26.7. | Waiver..... | 44 |
| 26.8. | Governing Law | 44 |
| 26.9. | Costs of Enforcement..... | 44 |
| 26.10. | Further Documentation | 44 |
| 26.11. | Estoppel Certificate..... | 44 |
| 26.12. | No Joint Venture..... | 45 |
| 26.13. | Mutual Drafting | 45 |
| 26.14. | Authority..... | 45 |

**POLE CANYON ANNEXATION AND MASTER
DEVELOPMENT AGREEMENT**

This Pole Canyon Annexation and Master Development Agreement is effective into as of the 19th day of Jan., 200~~9~~¹⁰, by and between Eagle Mountain City, a Utah municipal corporation, referred to in this Agreement as the "City", and those certain undersigned parties referred to herein as the "Pole Canyon Investment Group" or "PCIG".

RECITALS

Capitalized terms have the meaning given to them in Schedule One attached hereto and incorporated herein.

This Agreement is made with reference to the following facts.

The Petitioners for annexation set forth on Exhibit 1 filed two (2) separate Petitions for Annexation on October 20, 2008 to annex the land located in unincorporated Utah County described in Exhibit 1 (hereafter collectively referred to as the "Annexation Property" or "Master Planned Area"). The Annexation Property is to be annexed to the City under the terms of this Agreement and applicable law.

The land in Petition 1 in Exhibit 1 is intended to be annexed and developed primarily for residential use and the land described in Petition 2 of Exhibit 1 is intended to be developed primarily as a Business Park or for other commercial and/or light industrial use.

Part of the Annexation Property is the property owned by the PCIG and to be planned and developed by the PCIG, which is more particularly described in Exhibit 2 (hereafter the "PCIG Property"). The PCIG Property is owned by the following parties which comprise the Pole Canyon Investment Group: Oquirrh Wood Ranch, LLC, a Utah limited liability company; and GSFJV, LLC, a Utah limited liability company.

(The ownership of the PCIG Property is more particularly set forth in the Pole Canyon Master Development Plan.) Plats A, B and C of the existing White Hills Subdivision (collectively "White Hills Subdivision"), the White Hills Country Estates, and the property owned as of the date of this Agreement by Kenneth F. White (Parcel Nos. 86736-97 and 45320-93) (the "Kenneth White Property"), all as depicted in Exhibit 2, are included within the Annexation Property, but are among the parcels of property expressly excluded from the definition of the PCIG Property.

The portion of the Annexation Property which is not included as part of the PCIG Property (including but not limited to the White Hills Subdivision, the White Hills Country Estates, and the Kenneth White Property) is not owned or controlled by PCIG, and reference is made herein to such property for the sole purpose of annexing such property into the City. Such property of all other persons not signing this Agreement shall be referred to herein as the "Annexation Only Property," and is more particularly identified as Areas A through I in Exhibit 2.

Exhibit 2 is the Land Use Element of the Pole Canyon Master Development Plan, and identifies areas to be zoned by the City for development by PCIG, along with areas designated as areas A through I which are zoned for agricultural use only.

The PCIG Property, all of which is designated as part of the "Master Planned Area", will be zoned, planned and developed in accordance with this Agreement, the laws of the State of Utah and the Codes and Ordinances of Eagle Mountain City, and as more particularly set forth in the "Pole Canyon Master Development Plan," which Plan includes this Agreement as the Master Development Agreement, together with all Exhibits to this Agreement.

The PCIG plans to develop the PCIG Property by emphasizing the natural environment of the Master Planned Area, with trails, parks, and other open space, and

further has a goal of carefully and responsibly managing natural resources located within the area, while putting such resources to full beneficial use, including without limitation, agricultural uses, land and water. Without limiting the generality of the foregoing, the Master Planned Area has been and will continue to be planned pursuant to the following “planning goals”:

- Compliance with the laws and regulations of the City and the State of Utah
- Maintain Rural / Country Atmosphere
- Maintain Quiet, Friendly, Safe Neighborhoods
- Prioritize Trails, Parks & Open Space
- Create Active Lifestyle Neighborhoods
- Provide Access to Recreation Areas
- Plan for Quality / Managed Growth
- Provide Needed Infrastructure
- Create Local Jobs & Tax Base
- Make Appropriate Contribution(s) to Valley-wide Amenities
- Emphasize Property’s Views along with Areas Natural Environment
- Use CC&R’s and Technical Guidelines to Encourage Conservation & Eco-friendly Development
- Offer More for Less in terms of Lot Size, Amenities, Quality & Affordability

The PCIG has spent several years and considerable resources in performing master planning so that as development occurs, it can happen in a quality, well-managed fashion. The City acknowledges that proposed infrastructure master plans have been prepared by (a) AQUA Engineering, with respect to the Wet Utility Master Plan (including a Wastewater Collection and Treatment Analysis, a Water System Analysis, and a Storm Drainage Analysis) attached hereto as Exhibit 5 of the Pole

Canyon Master Plan, (b) Intermountain Consumer Professional Engineers, with respect to the Dry Utility Master Plan attached hereto as Exhibit 6, and (c) DMJ Harris, with respect to the Traffic Impact Study attached hereto as Exhibit 7 and except as the Exhibits are modified by this Agreement or City standards (the Wet Utility Master Plan, the Dry Utility Master Plan, and the Traffic Impact Study are collectively referred to herein as the proposed "Pole Canyon Infrastructure Plan". Additional master plans, studies, reports, and other information prepared by the PCIG in connection with the extensive master planning relating to the Project is attached hereto and incorporated herein as Exhibit 13, and is incorporated as part of the Pole Canyon Master Development Plan.

Without limiting the generality for the foregoing, the City and the PCIG acknowledge that, under the terms of the Pole Canyon Infrastructure Plan as revised for City approval, PCIG proposes that phasing of construction will occur on a demand basis (i.e., 4-way stop roadway intersections until anticipated densities justify roundabouts, sizing of main utility lines, etc.), with the intent of providing necessary and adequate infrastructure through justifiable phasing, in order to keep lots and homes affordable for end purchasers. Financing for Public Infrastructure and Improvements addressed in the Pole Canyon Infrastructure Plan will occur in a manner which is consistent with the terms of this Agreement and the Local District Agreement.

The Pole Canyon Master Development Plan divides the Master Planned Area (for planning purposes only) into approximately twenty one (21) geographic sub-areas referred to herein as "Neighborhood Planning Areas," "Commercial Planning Areas," and "Business Park Planning Areas" (collectively "Planning Areas"). Such Planning Areas will include portions of property within the PCIG Property designated for residential, mixed-use, commercial, business park / industrial, and/or other forms of development. The Planning Areas described in the Land Use Element at Exhibit 2 are intended to indicate the zoning, use, and vested density for each area and provide

zoning for the PCIG and the City with respect to planning and development decisions. PCIG and the City are aware of substantial infrastructure which will be needed by the City to assume responsibility for the Annexation Property and the parties have described "special conditions" in paragraph 18 herein to meet the reasonable needs of the City and its citizens.

The City and the PCIG wish to define the rights and responsibilities of the parties with respect to the development of the land and funding for public improvements in the PCIG Property, pursuant to the Pole Canyon Master Development Plan, which Pole Canyon Master Development Plan is approved by the City pursuant to this Agreement.

NOW, THEREFORE, in consideration of the mutual covenants and promises of the parties contain herein, the parties agree as follows:

1. Conditions to Obligations. The obligations of the PCIG and the City hereunder are contingent upon and subject to the satisfaction of each of the following conditions.

1.1. Annexation. The Annexation Property shall have been annexed into Eagle Mountain City in accordance with Utah's annexation statute (*Utah Code Ann. §§ 10-2-401 et seq.*), and the City's annexation policy plan, as the same shall be amended. The City acknowledges that the PCIG, together with other persons not parties to this Agreement, have filed and the City has accepted two (2) Petitions for Annexation with the City relating to the Annexation Property. The City shall annex the Annexation Property in accordance with the laws of the State of Utah and the policy and review process created by the City for this Annexation and Annexation Petitions.

1.2. Zoning . The PCIG Property and the Annexation Only Property, upon the City's grant of annexation, shall be zoned in accordance with the Land Use Element of the Pole Canyon Master Development Plan, attached hereto as Exhibit 2. In order to provide appropriate transitioning for the existing residents of the White Hills Subdivision, all lots in Neighborhood Planning Area 11 shall have a lot size of at least 10,000 square feet. In Neighborhood Planning Areas 1 and 3, a street with lots on both sides of the street of at least 10,000 square feet in size shall abut the existing White Hills Subdivision.

2. Pole Canyon Investment Group Representative . The PCIG represents and warrants that OWR has, by virtue of separate agreements entered into between OWR and each member of the PCIG, authority from each member of the Pole Canyon Investment Group to exercise full control and management of the entitlement and planning of the PCIG Property, including without limitation the right to represent the Pole Canyon Investment Group in connection with entitlements and other approvals needed from the City for development of the Property. Without limiting the foregoing, each member of the PCIG hereby acknowledges, confirms and ratifies its appointment of OWR as such member's duly authorized agent to make plan, consult with, make applications to, bind, and otherwise represent the interests of such PCIG member with respect to the planning and entitlement of the PCIG Property, and the other rights, obligations, and interests of the PCIG, all as further set forth in this Agreement. Without limiting the generality of the foregoing, each member of the PCIG further acknowledges that in no case shall any member of the PCIG (except for OWR) have any rights whatsoever to exercise any control or management over the entitlements or development of any property not owned by such member. Accordingly, the City and the PCIG agree that the City shall work directly with, and is permitted by the members of the PCIG to rely upon the decisions and representations made by OWR.

3. Development of the Project. Subject to the terms and conditions of this Agreement, including but not limited to Section 5.1 below, development of the Project shall be in accordance with the City's Code in effect on the date a Development Application is filed with the City

4. Planning Areas; Development of the PCIG Property in Compliance with the Pole Canyon Master Development Plan.

4.1. Planning Areas Generally. The parties hereto acknowledge that the Pole Canyon Master Development Plan incorporates the use of geographic sub-areas, referred to herein as "Planning Areas" (including Neighborhood Planning Areas (also known as "Residential Areas"), Commercial Planning Areas and Business Park Planning Areas (also known as "Industrial Areas")) for purposes relating to phasing, planning of infrastructure, financing, standards of construction, and for other similar planning and development-related purposes. Notwithstanding anything herein to the contrary, the PCIG and the City agree that the boundaries of the Planning Areas set forth in the Pole Canyon Master Development Plan may be modified by the PCIG with prior written approval of the City based upon changes to community layout and infrastructure planning, market conditions, and for other similar reasons. It is anticipated that, in addition to the Technical Guidelines, as each Planning Area is planned and developed it will have its own "sub" technical guidelines relating to more Planning Area-specific General Development Standards and other development guidelines for such Planning Area, provided that such Planning Area Technical Guidelines shall be consistent with and subject to the Technical Guidelines. Modifications to Planning Area boundaries may involve amendment of the Pole Canyon Master Development Plan and re-zoning of the lands to be included within new Planning Area boundaries if the

boundary change creates a change in use or increase in density of the land to be included in the revised boundary.

4.2. Phasing. The City acknowledges that the PCIG, future assignees of the PCIG, and/or Subdevelopers who have purchased Parcels within the PCIG Property will develop the PCIG Property in phases. The Planning Areas will serve as general phasing boundaries for phases of the Project, although no sequential phasing is implied by the numbering set forth in the Pole Canyon Master Development Plan. The parties acknowledge that the most efficient and economic development of the Project depends on numerous factors, such as market conditions and demand, infrastructure planning, competition, the public interest and other similar factors. PCIG acknowledges that the primary motivation for the annexation of the Annexation Property by the City is the Commercial and Industrial development Plan for the Business Park Area. The timing, sequencing, location and phasing of the Project, including but not limited to construction of water and storm drain systems, parks, and other public infrastructure and city-wide improvements, shall be as determined by the PCIG in its reasonable business judgment and discretion, and consistent with the Infrastructure Plan and Local District Agreement previously approved by the City Council. Furthermore, the parties acknowledge and agree that the Public Infrastructure and Improvements are to be installed in accordance with the initial phasing requirements for the Project, as set forth in the Infrastructure Plan and the Local District Agreement, and as may be required as development within phases proceeds. In this regard, it is anticipated that the Infrastructure and Financing Plans may be amended and/or updated by the PCIG and the City as phasing is modified and planning occurs by the PCIG, and as a result, the PCIG and the City agree to cooperate in good faith with respect to continued master planning and implementation of such master plan(s) consistent with the public interest.

4.2.1. Arterial Road Corridor. The PCIG and the City acknowledge that, pursuant to traffic studies conducted by traffic engineers on the existing State Road 73, such State Road has additional capacity to service a portion of the additional traffic caused from development of the Project, but that as development of the Project continues, construction of an additional arterial road corridor (currently referred to in the Pole Canyon Master Development Plan as "Pole Canyon Boulevard") will become necessary. To this end, the City and the PCIG agree that Pole Canyon Boulevard (or such other alternate access approved by the City) will be constructed when traffic volumes on State Road 73 are increased as a result of the development of the Project by either 655 vehicles per PM peak hour (for northbound traffic), or 718 vehicles per PM peak hour (for southbound traffic), as determined by a study performed by a licensed traffic engineer. As development proceeds, the City may require additional traffic studies to assess the traffic impact of any application for development approval. If the result of a traffic study required by the City indicates that the traffic volumes defined above may be exceeded by the relevant applications, if approved, and Pole Canyon Boulevard (or other alternate access approved by the City) has not been completed, the application may be denied by the City or stayed pending the completion of Pole Canyon Boulevard or an alternate access approved by the City.

4.3. Project Maximum Density. At Buildout of the Project, the PCIG shall be entitled to have developed the Maximum Residential Units (including the densities identified in the Land Use Element attached as Exhibit 2 on a Neighborhood Planning Area basis), and to have developed the other Intended Uses as specified in the Pole Canyon Master Development Plan, provided that

PCIG has complied with applicable provisions of the City's Code. Notwithstanding anything to the contrary herein, any City ordinance, amendment to the City's Code, or other development standard enacted, implemented, regulated and/or enforced by the City on or after the date of this Agreement which has the effect of prohibiting and/or materially and unreasonably restricting the PCIG's rights to develop the vested densities set forth in the Land Use Element, including but not limited to any ordinance, amendment, or other development standard which increases or otherwise modifies minimum lot size requirements, setbacks, frontage requirements, or other similar standards which relate to or have an effect on densities, shall be inapplicable to the PCIG Property (or modified to the extent necessary to permit the PCIG to develop the vested densities set forth in the Land Use Element), unless the Council, on the record, finds that a compelling, countervailing public interest would be jeopardized without applying such ordinance, amendment or standard to the PCIG Property. Furthermore, no future ordinance or amendment to the City's Code shall materially increase the amount of exactions or dedications vested in the PCIG under this Agreement and the Pole Canyon Master Development Plan, unless such exactions are required to provide services to the PCIG Property. The City makes no guarantee or warranty that the entitled Maximum Residential Units can be achieved, and the parties acknowledge that as development progresses certain market, infrastructure, and/or other similar constraints beyond the control of the parties may be presented which could prevent the practical use of all vested densities granted in the Pole Canyon Master Development Plan.

4.3.1. Density Transfer. Density may be transferred according to the Density Allocation Exhibit attached hereto as Exhibit 4 upon designation by the PCIG with review and approval of the City. The density in a Neighborhood Planning Area may not exceed the percentage

designated in Exhibit 4. Density transfer approval shall take place with the master development plan application by the PCIG and approval for each Neighborhood Planning Area, or along with a subdivision or site plan approval for the applicable Neighborhood Planning Area, subject to City review and approval for land use capability and compatibility with neighborhood land uses and development, provided that the aggregate Density for the PCIG Property shall not exceed the Maximum Residential Units.

4.4. Uses and Densities. Intended Uses which are allowed within one or more Planning Areas, as well as anticipated Densities for each Planning Area, are vested as shown in the Pole Canyon Master Development Plan Land Use Element and future City subdivision development standards shall respect the right of PCIG to develop up to the vested density.

4.5. Accounting for Density for Parcels Developed by the PCIG. At the recordation of a Final Plat or Commercial Site Plan allowing for residential uses or other approved and recorded instrument for any Parcel(s) within a Planning Area developed by the PCIG, then the member of the PCIG whose property is directly affected shall provide the City a Development Report showing any Density used with the Parcel(s) and the Density remaining with the PCIG for such Planning Area and for the remaining Project.

4.6. Accounting for Density for Parcels Sold to Subdevelopers. Any Parcel sold by the PCIG to a Subdeveloper shall include the transfer of a specified portion of the Maximum Residential Units and, for any non-residential use, shall specify the amount and type of any such other use sold with the Parcel. At the recordation of a Final Plat or other document of conveyance for any Parcel sold to a Subdeveloper, the PCIG shall provide the City a Sub-

Development Report showing the ownership of the Parcel(s) sold, the portion of the Maximum Residential Units and/or other type of use transferred with the Parcel(s), the amount of the Maximum Residential Units remaining with the PCIG and any material effects of the sale on the Pole Canyon Master Development Plan.

4.6.1. Return of Unused Density. If any portion of the Maximum Residential Units transferred to a Subdeveloper are unused by the Subdeveloper at the time the Parcels transferred with such Density receives approval for a Development Application for the final portion of such transferred Parcels, the unused portion of the transferred Maximum Residential Units shall automatically revert back to the PCIG and the PCIG shall file with the City a Development Report, but shall not be used to exceed the maximum allowable density approved in this Agreement.

5. Zoning and Vested Rights.

5.1. Vested Rights Granted by Approval of this Agreement. To the maximum extent permissible under the laws of Utah and the United States and at equity, the City and the PCIG intend that this Agreement grants the PCIG all rights to develop the Project in fulfillment of this Agreement without modification or interference by the City except as specifically provided herein. The Parties intend that the rights granted to the PCIG under this Agreement are contractual and also those rights that exist under statute, common law and at equity. The parties specifically intend that this Agreement grants to the PCIG “vested rights” as to, among other things, the density approved and land uses, as that term is construed in Utah’s common law and pursuant to Utah Code Ann. §10-

9a-509 (2008) with respect to the matters set forth in this Agreement, i.e. the Project Densities and Intended Uses, except as specifically provided herein.

5.2. Term of Agreement. The term of this Agreement shall be until December 31, 2019. If as of that date the PCIG has not been declared to be in default as provided in Section 23, or if any such declared default is not being cured as provided therein, then this Agreement shall be automatically extended until December 31, 2029. If as of December 31, 2029, the PCIG has not been declared to be in default as provided in Section 23, or if any such declared default is not being cured as provided therein, then this Agreement shall be further automatically extended until December 31, 2039.

6. Approval Processes for Development Applications.

6.1: Processing Under City's Code. Approval processes for Development Applications shall be as provided in this Agreement, the Pole Canyon Master Development Plan, and the City's Code,. Each Neighborhood Planning Area shall be required to submit and obtain approval of a master development plan for the relevant area before development approval in the Neighborhood Planning Area is granted in any form by the City. Development Applications shall be approved by the City if they comply with the Existing Applicable Building Codes and the City's Code in effect on the date the Application for development approval is filed with the City. Nothing in this Section 6 shall be construed to require the PCIG or any Subdeveloper to obtain further City zoning approval with respect to a Parcel's Intended Use or Density as set forth in Exhibit 2, or rights granted to the PCIG herein, provided that such Development Applications comply with the terms set forth in this Agreement and the Pole Canyon Master Development Plan, the applicable

neighborhood master development plan and the City's Code in effect on the date of the Application for development approval.

6.2. City's Cooperation in Processing Development Applications. The City and each Development Applicant, including PCIG shall cooperate reasonably in promptly and fairly processing Development Applications.

6.3. [Intentionally Omitted.]

6.4. Independent Technical Analyses for Development Applications. If the City needs technical expertise beyond the City's internal resources to determine impacts of a Development Application such as for structures, bridges, water tanks, "threatened and endangered species" and other similar matters which are not required by the City's Code to be certified by such experts as part of a Development Application, the City may engage such experts as City Consultants with the actual and reasonable costs being the responsibility of Applicant. If the City needs any other technical expertise other than as specified above, under extraordinary circumstances specified in writing by the City, the City may engage such experts as City Consultants with the actual and reasonable costs being the responsibility of Applicant.

6.5. City Denial of a Development Application. If the City denies a Development Application, the City shall specify in writing in reasonable detail the reasons the City believes that the Development Application is not consistent with this Agreement and/or the City's Code.

6.6. Meet and Confer regarding Development Application Denials. The City and Applicant may meet within a reasonable time after denial of a Development

Application to review the issues specified in the denial of a Development Application.

6.7. City Denials of Development Applications Based on Denials from Non-City Agencies. If the City's denial of a Development Application is based on the denial of the Development Application by a Non-City Agency, the PCIG may appeal any such denial through the appropriate procedures for such a decision.

7. [Intentionally Omitted.]

8. Open Space and Trails Requirements. In the Development Application for each separate Parcel, the Applicant shall designate the land required for Open Space and/or Trails as provided in the Pole Canyon Master Development Plan and the City's Code (to the extent not inconsistent with the Open Space and/or Trails Exhibit attached hereto as Exhibit 8) and the Applicant shall be required as a condition of approval to dedicate and construct required trail segments.

8.1. Regional Parks. City and the PCIG anticipate that Regional Parks will need to be constructed on portions of the PCIG Property according to the Parks and Open Space Master Plan. The PCIG shall cooperate with the City in the siting, planning, design and financing of the Regional Parks, and such Regional Parks shall be proposed by the City for identification in the City's capital facilities plan. The PCIG and the City shall provide for the acquisition of such property, whether through dedication of the necessary property to the City in exchange for credits against Impact Fees or reimbursement for excess capacity required by the City, and/or through other methods.

8.1.1. Lagoon Property. The PCIG shall construct a specialized Recreation Area (which the parties acknowledge may be treated by the City as a regional park, and incorporated as part of the City's capital facilities plan) on property currently consisting of a lagoon(s) or another site proposed by PCIG and approved by the City, which lagoon property shall be sold to OWR by the City for a purchase price equal to \$218,000 less all of the cash received by the City from WHSSD pursuant to the WHSSD Agreement, provided that in no event shall the purchase price paid by OWR for the lagoon property exceed \$130,000. The purchase price shall be payable in a single lump sum at closing. Closing shall occur within thirty (30) days after notice from the City to the Buyer that the sale shall be closed. The City shall convey the property "as is", without warranty, by quit claim deed subject to all encumbrances of every kind of record or which are observable on the property as of the date that the City obtains title to such property from the WHSSD, but excluding any encumbrance of record or observed on the property by or as a result of actions (or inactions) of the City prior to transfer to OWR. OWR and the PCIG have inspected the property and are fully informed about the use of the property by the WHSSD. Certain changes to the property may be required to facilitate the termination of the use of the property as a sewer lagoon. OWR may elect to purchase title insurance at OWR's expense. Failure of OWR to close the purchase of the property shall be considered a default in the terms of this Agreement by the PCIG. Notwithstanding the foregoing, the PCIG may propose a change of location of such Area, provided that the size of the facility is equal to or greater than the size of the current proposed use to be located on the lagoon property and that the lagoon is fully decommissioned at the expense of PCLD prior to the date of public use.

8.2. Rodeo Grounds. The PCIG shall cause to be subdivided and dedicated to the City as a specialized Recreation Area (which the parties acknowledge may be treated by the City as a regional park, and incorporated as part of the City's capital facilities plan as further set forth below) a Parcel of approximately twenty (20) acres within the PCIG Property, for the purpose of a public rodeo grounds; provided, however, that the PCIG will develop the rodeo grounds as an amenity by the earlier of (a) the date on which the aggregate market value of the PCIG Property (as determined by the Utah County Assessor's office) is equal to or greater than \$250 million, or (b) June 1, 2015, unless such deadline is extended at the request of the PCIG (at the discretion of the Council), considering whether an adequate demand exists within the City for such rodeo grounds at the time of the request. The rodeo grounds to be constructed shall include: a gravel parking area, one (1) rodeo-equipped riding arena, holding pens, bleachers for five hundred (500) spectators, one (1) separate riding ring or warm-up pen, lighting for the riding areas and security lighting for the parking area, restrooms (4 stalls for men and 6 stalls for women), and concession areas. This area will also be capable of hosting a high school rodeo and will include the following: lighted secondary "warm-up" arena with bleacher seating for at least two hundred (200) people, restroom facilities, concession area(s), parking, and other amenities as may be necessary to host a high school rodeo at a minimum standard. The currently anticipated location of such rodeo grounds is identified in the Pole Canyon Master Development Plan. The improvements provided with respect to the rodeo grounds may be publicly financed through the Pole Canyon Local District. The City agrees to consider incorporating the proposed rodeo grounds into the City's Capital Facilities Plan for cost reimbursement or impact fee credit, with respect to the costs associated with such rodeo grounds, if considered and approved in the City Impact Fee process. The rodeo grounds dedicated to the City shall be consistent with the design and construction quality of rodeo grounds and facilities of similar sizes located

within the State of Utah. The City shall be required to maintain such rodeo grounds following dedication, and shall also be required to pay for any costs associated with "up-sizing" the rodeo grounds or facilities beyond that which is described in this Section.

8.3. Interim Equestrian Facility. The PCIG agrees to provide for the City's use and enjoyment on or before May 1, 2010, the equipment and temporary facilities for an interim equestrian facility (for use prior to the completion of permanent rodeo grounds as provided in Section 8.2 above) to be located at the existing Pony Express Park (which location shall be provided by the City at no cost to the PCIG). Such interim facilities shall include the riding arena and bleacher seating that will later be moved and used as the "warm-up" arena at the permanent rodeo grounds. This arena will be sufficient in size, construction and equipment, to host barrel racing, roping, and other equestrian and horse-related events, excluding bull riding, bronc riding, and other "rough stock" events, with movable bleacher seating for two hundred (200) spectators (with additional temporary seating for three hundred (300) additional spectators provided for the Pony Express Sesquicentennial event). The City agrees to provide reasonable and adequate liability insurance relating to the public use of the interim equestrian facility, and to obtain customary liability releases signed by rodeo participants, in favor of the City and the PCIG. The City agrees to release, indemnify and hold the PCIG harmless from and against all claims, including but not limited to personal or bodily injury, damage to property, or otherwise, arising from or relating to the public's use of the interim equestrian facility, except to the extent caused by the negligence of the PCIG."

8.4. Creation of Open Space and/or Trails. Open Space and/or Trails shall generally be created and/or dedicated by means of a Subdivision or a Commercial Site Plan to which the Open Space and/or Trails are either internal

or contiguous. The City acknowledges that it may not be in the interest of either the City, the PCIG, assignees of the PCIG or Subdevelopers to always dedicate Open Space and/or Trails on such a contiguous basis which may result in constructing and/or designating incremental, small, unusable parcels of land. Therefore, each Development Application approval shall provide for the designation and/or construction of Open Space and/or continuous Trails in such amounts as are determined to be appropriate by the City considering:

8.4.1. The amounts and types of Open Space and/or Trails proposed in the Application and provided on the portions of the Project previously developed;

8.4.2. The amounts and types of Open Space and/or Trails proposed in the Application and remaining to be designated and/or constructed pursuant to the Pole Canyon Master Development Plan; and

8.4.3. If the development Application is for development of a commercial or industrial parcel, the amount and nature of the land and the types of land uses proposed by the Development Application.

8.5. Public Access to Open Space and/or Trails. Unless otherwise provided in the approval of a Development Application (such as for an amenity in the control of a Homeowners Association for the exclusive benefit of the members of the Homeowners Association, or with respect to private property subject to a deed restriction or other restrictive covenant as approved by the City), the public shall have access to all Open Space and/or Trails whether the same are dedicated to the City or to some other entity. Notwithstanding anything to the contrary herein, the PCIG and the City anticipate that the PCIG shall phase out

the existing "ATV" trail system located on the PCIG Property as the master trail system is completed.

8.6. Accounting for Open Space for Parcels Developed by the PCIG. The Open Space requirements for the Project are as set forth in the Pole Canyon Master Development Plan, and such requirements must be met by compliance with the City Open Space and/or Trails standards as set forth in the City's Code to the extent not inconsistent with the Open Space and/or Trails Exhibit attached hereto as Exhibit 8. In this regard, the City Standards require 178 total acres of Open Space, including 27 total acres of regional Parks, 71 acres of Community Parks and 62 acres of Neighborhood Parks. The Open Space Standards require approximately 17.7 acres of pocket parts and off-street trails as proposed by PCIG or its successors in interest during the planning process in compliance with the City Master Parks and Open Space Plan. The general location of Open Space and Parks is designated on Exhibit 8 for Regional and Community Parks. Regional and Community Parks must be dedicated and improved as required by City Standards and phases based on the development of adjoining plats. At the recordation of a Final Plat or Site Plan allowing for residential uses or other approved and recorded instrument for any Parcel(s) within a Planning Area developed by the PCIG, the PCIG shall provide the City an Open Space Report showing any Open Space planned for development with the Parcel(s) and the Open Space requirement remaining with the PCIG for such Planning Area and for the remaining Project. The Open Space requirement for the Project may be met by either the "master" Open Space and/or Trails, or the Open Space and/or Trails found exclusively in individual Planning Areas, Parcels and/or Subdivisions. The City will not record any plat if the required Open Space and/or Trails relating to the applicable property have not been dedicated to the City at, or prior to the recordation of, each proposed plat or Commercial Site Plan.

8.7. Accounting for Open Space for Parcels Sold to Subdevelopers. Any Parcel sold by the PCIG to a Subdeveloper shall include the transfer and delegation to such Subdeveloper of a specified portion of the City's Open Space requirement found in the City's Code. At the recordation of a Final Plat or other document of conveyance for any Parcel sold to a Subdeveloper, the PCIG shall provide the City a "sub" Open Space Report showing the amount of Open Space planned for the particular Parcel(s), and the amount of the Open Space requirement under the City standards transferred and delegated with the Parcel(s).

8.7.1. Credit for Additional Open Space. If any portion of the PCIG Property purchased by a Subdeveloper is designed and constructed such that there is a greater amount of Open Space in such portion of the PCIG Property than what is required under this Agreement and the Technical Guidelines for the Planning Area, then the excess Open Space planned and constructed by such Subdeveloper shall automatically be credited towards the Open Space requirement for the Planning Area. In such event, the PCIG shall file with the City an Open Space Report to notify the City of such credit.

8.8. Notice to City. Upon the initial filing of any Development Application in which Open Space, Local Parks and/or Trails are located, the PCIG and/or Subdeveloper shall provide separate written notice to the City of its intent to dedicate the proposed parcels of Open Space and/or Trails as a part of the final recorded instrument approving the Development Application. Notice shall be provided to the Mayor, Planning Director and City Engineer and shall include a current title report and statement of all ad valorem taxes due. Within sixty (60) days of receipt of the Notice, the City shall make an initial determination

whether the City intends to accept dedication of the Open Space and/or Trails or will accept the proposed designation on conditions specified in the determination. If the City does not intend to accept dedication of the Open Space and/or Trails the City shall notify Applicant of its decision. The City's notification that it does not intend to accept dedication of the Open Space and/or Trails shall constitute a waiver of its right to receive an outright conveyance of fee title to that parcel. If the City does not exercise this option, such Open Space and/or Trails shall be offered to Utah County, a conservation organization, a Homeowners Association or another similar designated entity reasonably acceptable to the City.

8.9 Dedication of Open Space and/or Trails. Dedication of the Open Space and/or Trails to the City shall be by plat recordation or by dedication by deed acceptable to legal counsel for the City from the PCIG or a Subdeveloper which shall be without any financial encumbrance or other encumbrance including easements) or property taxes, or which interfere with the use of the property for Open Space and/or Trails in the judgment of the City. ATV trails and equestrian trails are depicted on Exhibit 4 and are included within the Open Space and/or Trails required to be dedicated to the City.

8.10 Maintenance of Open Space and/or Trails. Upon acceptance by the City of the proffered Open Space and/or Trails and after formal possession, the City shall be responsible for maintaining the Open Space and/or Trails after final inspection, acceptance of the improvements to the Open Space and/or Trails, if any, and expiration of the applicable warranty term. If the Open Space and/or Trails are dedicated to an entity other than the City then the dedication shall provide for maintaining the Open Space and/or Trails in a manner to be reasonably acceptable to the City.

8.11. Tax Benefits. The City acknowledges that the PCIG intends to seek and qualify for certain tax benefits by reason of conveying, dedicating, gifting, granting or transferring Open Space and/or Trails to the City or to a charitable organization. The PCIG shall have the sole responsibility to claim and qualify for any tax benefits sought by the PCIG by reason of the foregoing. The City shall reasonably cooperate with the PCIG to the extent reasonable under law to allow the PCIG to take advantage of any such tax benefits.

9. Infrastructure and Improvements.

9.1. Design and Construction of Public Infrastructure and Improvements. The City and the PCIG acknowledge that significant On-Site Infrastructure, Off-Site Infrastructure, Backbone Infrastructure and other System Improvements, and other related improvements (collectively "Public Infrastructure and Improvements") are required in connection with the development of the PCIG Property, including without limitation: (a) main and ancillary roadways, (b) traffic signals, (c) sewer, water and storm drainage systems, treatment plants, and other facilities, (d) utility (including power, gas, telephone, and fiber optics) systems, facilities, and plants, (e) public buildings, centers, pavilions, and other facilities, and (f) Open Space and/or Trails. The nature and type of Public Infrastructure and Improvements are more particularly set forth in the Pole Canyon Infrastructure Plan as revised in subsequent planning and reporting documents. The City and the PCIG shall cooperate in good faith to design, construct and/or acquire the Public Infrastructure and Improvements. The City shall consider all complete Development Applications and issue all permits reasonably necessary for the construction of the required Public Infrastructure and Improvements, provided that such issuance is consistent with the City standards as provided in the City's Code.

9.2. No Additional Off-Site Infrastructure Requirements. The City shall not, directly or indirectly, charge the PCIG, its affiliates or successors, Subdevelopers or the PCIG Property any development fees, Impact Fees, sewer capacity or hookup fees, or any similar fees, charges, assessments or exactions for Off-Site Infrastructure for the development of the Project except as may be otherwise allowed by law.

9.3. Pole Canyon Local District. The City acknowledges that the PCIG has previously facilitated the creation of a local district relating to the PCIG Property through Utah County (the "Pole Canyon Local District"). The Certificate of Creation establishing the Pole Canyon Local District pursuant to Utah Code Ann. § 17B-1-215 was executed by the lieutenant governor on June 23, 2009. The Pole Canyon Local District, as currently established, is comprised of the entire PCIG Property (which property excludes the White Hills Subdivision, the White Hills Country Estates, the Wilson Commercial Property and any property within the Master Planned Area not currently owned by OWR and GSFJV, LLC), as more fully depicted in the Local District Maps attached to and incorporated as Exhibit 9 of the Pole Canyon Master Development Plan. The Pole Canyon Local District is governed by representatives of PCIG and has been created for the purpose of financing and construction of up to four (4) services for each Local District permitted under Section 17B-1-202 of the Local District Act, including transportation (such as public transit and providing streets and roads, curb, gutter, and sidewalk), public recreation, sewer, water and storm drainage systems, and electric utilities systems. The parties hereto acknowledge that the Pole Canyon Local District acting only with the prior written approval of the City, will finance, construct, dedicate, and convey to the City (a) certain sewer lines and facilities, pursuant to and within the timing provided in the Agreement between the WHSSD and the City dated December ____, 2009, a copy of which is attached hereto and

incorporated herein as part of Exhibit 10 (the "WHSSD Agreement"), and (b) certain other Public Infrastructure and Improvements, pursuant to an Agreement between the Pole Canyon Local District and the City dated December ____, 2009, a copy of which is attached hereto and incorporated herein as part of Exhibit 11 (the "Local District Agreement"). As more fully set forth in the WHSSD Agreement and the Local District Agreement, it is contemplated that all of the Public Infrastructure and Improvements financed and constructed by the Pole Canyon Local District shall be approved and inspected by the City and dedicated to the City, free and clear of all liens and encumbrances, and that the PCIG shall be granted Impact Fee credits and reimbursements, if and when applicable, in consideration of its obligations to the Pole Canyon Local District. The Pole Canyon Local District financing does not modify or remove the obligation of PCIG or its successors in interest to complete all of the required public infrastructure required for development approval, subject to the issuance to the PCIG (or to its successors in interest) of impact fee credits and/or reimbursements for System Improvements if applicable. Therefore, regardless of whether or not the City decides to engage in financing of any kind or the use of tax increment payments as incentives to development, the parties understand and agree that the primary obligation for construction and financing of all infrastructure in the Project is the responsibility of PCIG and PCIG, or its successors in interest, is required as a condition of annexation, zoning and development approval to complete all public improvements and infrastructure without financial contribution from the City.

9.4. Special Assessment Area. As more fully set forth in the Local District Agreement, it is contemplated that Special Assessment Areas ("SAAs") will be considered by the City pursuant to the SAA Act, in the sole discretion of the Council for the purpose of providing financing for the construction and/or acquisition of certain of the Public Infrastructure and Improvements, as more

particularly set forth in the Local District Agreement and in the exclusive discretion of the City. It is anticipated that such SAAs may be established by the City and/or the Pole Canyon Local District for all purposes allowed by law, as more particularly set forth below and in the Local District Agreement.

9.4.1. Establishment by City of SAAs for Certain Improvements. The City shall work in good faith and in accordance with the Local District Agreement and in the sole discretion of the Council to establish when feasible and financially appropriate, one or more SAAs for (a) construction of utilities which are not included within the scope of the Pole Canyon Local District (including but not limited to natural gas, power), and (b) Public Infrastructure and Improvements which provide benefit to other parties in addition to the PCIG, and to other property besides the PCIG Property (and in such event, the area subject to the SAA should include all such benefited properties). Without limiting the generality of the foregoing, and as more particularly set forth in the Local District Agreement, the City may consider, in the sole discretion of the Council the establishment of an SAA to finance some or all of the following public improvements which may be required as a condition of Annexation in the initial phase of the development of the Project: (i) repairs/upgrading to the "White Hills Deficiencies" as outlined in the White Hills Infrastructure Report prepared by Horrocks Engineering, not to exceed \$350,000, and (ii) improvements required in connection with the WHWC water system being transferred to the City pursuant to the WHWC Transition Agreement (the "WHWC System Repairs"); as more fully set forth in the Pole Canyon Master Development Plan. The PCIG agrees to consent to the establishment of an SAA pursuant to this Section, and to execute an Acknowledgment Consent and Waiver and waive its protest rights and rights to a hearing with respect to the

establishment of an SAA, provided that the purpose of the SAA shall be consistent with the terms described in this Section. With respect to the WHWC System Repairs, the parties acknowledge that the PCIG will advance funds to make certain WHWC System Repairs, as more fully set forth in the Local District Agreement, and that the remaining WHWC System Repairs will be financed from proceeds of the sale of the SAA bond issued pursuant to this Section, all as more particularly set forth in the Local District Agreement and the WHWC Transition Agreement.

9.4.2. Fire Station. The parties acknowledge that the City may propose when financially feasible and when a sufficient demand is present the construction of a fire station on the PCIG Property. The City may consider financing the costs associated with the construction of the fire station, pursuant to the issuance of SAA bonds or otherwise. The site of the proposed fire station is depicted on Exhibit 2. At the request of the City, PCIG shall survey the fire station property and shall convey the real property identified in the survey to the City. The fire station property shall be conveyed by the PCIG to the City without cost to the City.

9.4.3. White Hills Park. The PCIG agree that Phase One of the White Hills Park (as more particularly described and identified in Exhibit 13.8) shall be completed on or before the one (1) year anniversary of the date of this Agreement. The parties acknowledge that it is currently contemplated that Phase One of the White Hills Park improvements will be financed by the Pole Canyon Local District. Upon completion, the White Hills Park property (including completed phases thereof) shall be conveyed by the PCIG to the City without cost to the City.

9.5. Community Development Area / Economic Development Area. The City acknowledges that the Pole Canyon Master Development Plan includes the planning of the construction of a substantial business park, which business park is anticipated to increase sales of property, economic activity, job growth, and tax revenues over the long term for the benefit of the City and PCIG. Among other reasons, and in an effort to induce and attract businesses to locate within the business park of the Master Planned Area, the City will consider upon the PCIG's request, the inclusion of the Business Park in the Redevelopment Area and Plan for the City including establishment of an Economic Development Area ("EDA") and/or a Community Development Area ("CDA"), pursuant to Title 17C of the Utah Code, which area(s) will include all or a portion of the PCIG Property intended for commercial, industrial, and/or commercial agricultural related services. The City agrees to consider assisting the PCIG in facilitating, negotiating, and obtaining necessary consents to the budget and terms of such EDA and/or CDA formed in connection with the PCIG Property, with tax entity committee(s) and/or other taxing entities, as applicable, which would be impacted by such tax increment financing.

9.6. Capital Facilities Plan and Impact Fees.

9.6.1. Preparation and Adoption of Capital Facilities Plan and Impact Fee. The City hereby agrees upon execution of this Agreement, to promptly initiate and schedule amendments to the City's current capital facilities plan with respect to the Public Infrastructure and Improvements to be financed with the assistance of the City. The City and the PCIG acknowledge that significant studies have previously been

performed by AQUA Engineering and other engineering consultants retained by the PCIG with respect to the consideration of certain Backbone Infrastructure and other System Improvements, and such studies have been useful in the City's preparation of amendments of the City's Capital Facilities Plan (but such studies will not be adopted as amendments to the City Capital Facilities Plan). Upon completion and approval by the City of an amended capital facilities plan, the City further agrees to consider an Impact Fee ordinance with respect to the facilities described in the Capital Facilities Plan and written analysis, including lawfully required credits against impact fees and reimbursement agreements benefitting PCIG, if applicable.

9.7. Construction Prior to Completion of Infrastructure. Anything in the City's Code notwithstanding, but subject to the requirements for fire protection, the PCIG may apply for and obtain Building Permits and/or temporary Certificates of Occupancy for uninhabited model homes, homes shows, sales offices, construction offices or similar uses prior to the installation of all Public Infrastructure and Improvements required to be eventually completed so long as PCIG is not in default of its obligations under this Agreement and such installation is secured consistent with the City's Code and the provisions of this Agreement.

9.7.1. No permanent Certificate of Occupancy shall be issued by the City, except in compliance with the City's Code.

10. Cable TV/Fiber Optic Service. Upon application to the City and approval of a Franchise Agreement for such facilities, the PCIG may install or cause to be installed underground all conduits and cable service/fiber optic lines within the Project at no expense to the City. The PCIG may contract with any cable TV/fiber optic provider of

its own choice and grant an exclusive access and/or easement to such provider to furnish cable TV/fiber optic services for those dwelling units or other uses on the Project, so long as the property is private and not dedicated to the public. The City may charge and collect all taxes and/or fees with respect to such cable service and fiber optic lines as allowed by contract with the PCIG or its successor in interest.

11. Enforcement of Technical Guidelines and CC&R's. The Design Review Committee, with respect to the Technical Guidelines and the Master CC&R's, and the Homeowners Association(s), with respect to the "sub" CC&R's, will be responsible for the implementation, enforcement, and amendment of such Technical Guidelines, and/or CC&R's, as applicable. The City shall not be responsible for the enforcement of private agreements or CC&R's.

12. Payment of Fees.

12.1. General Requirement of Payment of Fees. The PCIG and/or a Subdeveloper shall pay to the City all fees in amounts and at times specified in the City's Code.

12.2. Infrastructure Built by the PCIG. Upon application to and approval of the City, the PCIG or Subdevelopers may, from time-to-time, install and construct portions of the infrastructure specified in the Pole Canyon Infrastructure Plan which are System Improvements. The City shall comply with Utah Impact Fee law.

12.3. Reimbursement for "Upsizing". The City shall not require the PCIG to "upsized" any public improvements (i.e., to construct the improvements to a size larger than required to service the Project) unless financial arrangements reasonably acceptable to the PCIG are made to compensate the PCIG for the pro

rata costs of such upsizing. Compensation to the PCIG for any “upsizing” of the public improvements shall be agreed to by the PCIG and the City as a part of the Pole Canyon Financing Plan.

13. Permits; Security for Improvements.

13.1. Building Permits. No Building Permit shall be issued by the City for construction in the PCIG property, unless PCIG or its successor has substantially completed the required infrastructure to comply with City requirements for phasing of infrastructure and completion of off-site improvements required by the relevant project or proposed construction. Except as set forth in any provision of the City’s Code, no buildings, improvements, or other structures shall be constructed within the Project without the PCIG and/or a Subdeveloper first obtaining an appropriate Building Permit(s), and/or grading and excavation permits, as applicable. The PCIG and/or a Subdeveloper may apply for and obtain a grading permit following approval of a Commercial Site Plan or a Subdivision Site Plan if the PCIG and/or a Subdeveloper has submitted and received approval of a site grading plan from the City Engineer and all required fees are paid.

13.2. City and Other Governmental Agency Permits. Before commencement of construction or development of any buildings, structures or other work or improvements upon any portion of the Project, the PCIG or a Subdeveloper shall, at its expense, secure, or cause to be secured, any and all permits which may be required by the City or any other governmental entity having jurisdiction over the work. The City shall reasonably cooperate with the PCIG or a Subdeveloper in seeking to secure such permits from other governmental entities.

13.3. Security for Public Improvements. The completion of all improvements shall be subject to collateral requirements established by the City using forms for cash escrow or surety approved by the City Attorney. Any such security shall be, at the PCIG's request, partially released pro rata as work proceeds, to a maximum of ninety percent (90%). Upon Substantial Completion of the On-Site or Off-Site Infrastructure, as certified by the PCIG's engineers, the remainder of such security, except ten percent (10%) as security for a one (1) year warranty against defects in materials and workmanship, shall be released. At the end of the one (1) year warranty, unless the PCIG has been notified by the City of any repairs required under the warranty, the remaining security shall be released to the PCIG upon the City's determination that there are no further warranty repairs required. Unless otherwise required in a subsequent Development Agreement, no security shall be required for any improvements that are not designated to be dedicated to the City, nor for any improvements that are constructed by a public or quasi-public entity, including but not limited to the Pole Canyon Local District.

13.4. Separate Security for Landscaping. Security for the completion of those items of landscaping that are weather dependent shall be provided as required by the City's Code.

14. Dedication of Public Improvements. The PCIG agrees that all of the infrastructure and improvements dedicated to the City pursuant hereto shall be constructed to the City's standard specifications unless otherwise agreed in this Agreement or otherwise, and shall be subject to City requirements for the payment of property taxes, inspections and approval before acceptance by the City. The City agrees to accept such dedication after payment of all taxes and fees and inspection and correction of any deficiency or failure to meet City standards.

15. City's Obligations. Subject to the PCIG's performance of its obligations hereunder, and consistent with the terms and conditions provided herein, the City agrees that it shall provide the PCIG Property with standard municipal services in compliance with state laws and City Ordinance to the level of service feasible under City staffing and budgeting constraints, which level of services the City provides from time-to-time to other residents and properties within the City including but not limited to, garbage, snow removal, police, fire protection and other emergency services. Such services shall be provided to the PCIG Property on a reasonable basis, at reasonable levels, and on reasonable terms, conditions and rates, as appropriate under the circumstances, given the location of the property and prior, pre-existing conditions of the PCIG Property and subject to the conditions set forth above.

16. Water.

16.1. Generally. The parties acknowledge that the methodology for acquiring, utilizing, and otherwise managing the water issues relating to the Project has been studied at length, and is more fully summarized and set forth in the Pole Canyon Infrastructure Plan. The PCIG and the City also desire to cooperate in implementing techniques and methodology (for example, through implementation of restrictive covenants limiting residential water use) which emphasize the natural environment of the area and which encourage and promote the efficient use, maintenance and management of water resources, including without limitation through water-efficient landscaping and streetscaping, water-use reduction and/or reuse, and/or other innovative methods which are intended to manage water use in reasonable, cost-effective ways. In light of the foregoing, the PCIG and City agree that the PCIG Property shall be developed in accordance with and subject to the water right requirements which are incorporated in the City standards for dedication or contract fees in effect at the date of a Development Application.

16.2. Transfer of Water Rights, Water Sources, Water Storage, and Water Distribution Systems. The parties further acknowledge that the PCIG is currently negotiating with the City, WHWC, WHSSD, and the Pole Canyon Local District to secure sufficient water (and water systems) for the development of the PCIG Property. It is presently contemplated that (a) the City will request water for the Project from CUWCD through the CWP project when the City and PCIG conclude an agreement for such water, and (b) the WHWC will transfer its water rights to the City in exchange for water right banking credits in favor of OWR for the water rights approved as directed by the City and/or reimbursements in favor of OWR for the excess capacity in the water sources, water storage and water distribution systems benefiting the PCIG Property, with such transfer occurring pursuant to that certain White Hills Water Company Transition and Acquisition Agreement dated December ____, 2009, a copy of which is attached hereto as part of Exhibit 12 (the "WHWC Transition Agreement"). The City understands that any such transfer of water rights, water sources, water storage and water distribution systems may occur incrementally and in phases, and that the City may enter into a separate agreement to operate any water systems not previously transferred to the City. Any Impact Fees or related fees collected by WHWC and/or WHSSD, and not previously used for appropriate improvements or operations, will also be transferred to the City upon transfer of the system improvements, or portions thereof, to the City, to the extent that such Impact Fees or other fees relate to the portion(s) of the system improvements being transferred.

16.3. Additional Water Tank Property. If reasonably necessary for the planning and development of the Master Planned Area, the City agrees to consider initiating the acquisition of permits or property rights necessary to permit the installation of additional water tanks and distribution lines west of

the PCIG Property, which property is presently owned by the U.S. Bureau of Land Management, pursuant to the filing of a request for public purpose.

17. Rocky Mountain Power. Rocky Mountain Power currently provides electrical service to the Annexation Property. The City cannot furnish electrical utility services to consumers in the Annexed Property without receiving consent from Rocky Mountain Power to do so and without reimbursing Rocky Mountain Power for the value of the facilities owned by Rocky Mountain Power which the City must acquire in the Annexation Property. Rocky Mountain Power is preparing an inventory of the facilities in the Annexation Property and the relative value of the facilities to determine a cost that must be paid by the City to reimburse Rocky Mountain Power for the facilities. PCIG will have access to the inventory prepared by Rocky Mountain Power and may comment to the City and Rocky Mountain Power with respect to the values and resulting costs based on the inventory. The City anticipates that it will be necessary to negotiate an agreement with Rocky Mountain Power for a phased purchase of the existing electric utility facilities owned by Rocky Mountain Power before the City may begin providing electric utility services to consumers within the Annexation Property. The City agrees that it shall bear the costs paid to Rocky Mountain Power to acquire the electric utility facilities in the amounts and at the times required in the Purchase Agreement between Rocky Mountain Power and the City; provided, however, that the City shall have the right to recover such costs in full and as paid by the City from PCIG and related property owners deriving a benefit from the purchase of such facilities by the City. The City agrees to consult with the PCIG prior to making any payment to Rocky Mountain Power for the existing electric utility facilities, and to cooperate with the PCIG in making any challenge (whether through formal legal action or otherwise) to the amounts demanded by Rocky Mountain Power for such facilities.

18. Additional Easements. The PCIG shall exercise reasonable efforts to secure any necessary utility and similar easements or similar property rights (including without

limitation easements for water, sewer, power, gas, telephone, etc.) from neighboring property owners in connection with the planning and development of the PCIG Property. To the extent that the PCIG's efforts to secure necessary easements are unsuccessful due to issues beyond the reasonable control of the PCIG, the City may consider using its eminent domain power (to the extent permitted by applicable state and federal law) to obtain such necessary easements, provided that nothing in this Section shall be construed to obligate the City to exercise such power.

Notwithstanding the foregoing, the PCIG acknowledge that it is the responsibility of PCIG to acquire, plan, survey and dedicate the required easements and rights of way for infrastructure to the City, free of all encumbrances of every kind, including property taxes.

19. Agricultural and Agricultural Related Uses of Master Planned Area.

19.1. Generally. The City and the PCIG acknowledge that the Cedar Valley area has a deep and rich history in farming, ranching, and other agricultural related purposes and industries, and that the Pole Canyon Master Development Plan contemplates that such agricultural and agricultural related uses may continue in portions of the PCIG Property. Agricultural and agricultural related uses which continue under the terms of this Agreement may not be expanded or enlarged beyond the scope of operations in place as of the date of this Agreement and shall not be changed, unless the change is consistent with the Master Development Plan for the Pole Canyon area. Certain agricultural uses may be approved by the City as conditional uses where such approval is allowable under the City's Code.

19.2. Agricultural Use Prior to Development. Without limiting the generality of Section 19.1, and notwithstanding anything herein to the contrary, including the zoning and use provisions referred to herein and in the Pole

Canyon Master Development Plan, until such time as physical development and construction of the PCIG Property begins with respect to a relevant portion of such Property, the PCIG, and/or its successors, assigns, tenants, guests and invitees, shall be permitted to operate the PCIG Property for agricultural purposes, including without limitation, the present soil cultivation, crop production, raising and grazing livestock, and the present preparation of agricultural products for human use and their disposal all as contemplated in a farming and ranching agricultural operation. Fencing shall be permitted on the Property to (among other things) prevent parties from trespassing onto the PCIG Property, the City will use reasonable efforts to enforce the applicable law against such trespassing parties. Nothing in this Agreement shall be construed to affect or limit any presently permitted hunting, trap and other sport hunting, on land located outside of the PCIG Property, provided that adequate buffer areas (pursuant to applicable law) exist between such hunting areas, if any, and the development within the PCIG Property.

20. On-Site Processing of Natural Materials. Notwithstanding anything to the contrary herein, the PCIG, and/or its agents, successors, assigns, tenants, guests, and invitees shall be permitted to extract and process the natural materials located on the PCIG Property such as aggregate (rock, sand or gravel), for temporary purposes and in connection with the grading, excavation, and other ordinary and customary development processes for the PCIG Property. Such natural materials may be used in the construction of infrastructure, homes, or other buildings or improvements located on the PCIG Property and other locations outside the PCIG Property. No extraction, processing or other form of mining activities shall occur within the PCIG Property unless the party performing such activities has obtained necessary permits and approvals prior to commencement of such activities from the City.

21. Future Property Which May be Included in this Agreement.

21.1. Future Property within the Master Planned Area. If the PCIG acquires any additional property in the Master Planned Area, then such future property shall be automatically included within this Agreement at the option of the PCIG, and notice of this Agreement shall be recorded in the chain of title of such property. Any such future property acquired by the PCIG may be rezoned and if the future property is included within a Neighborhood Planning Area, the Maximum Residential Units may be designated at the same density unit rate used in the adjoining area.

21.2. Future Property not within the Master Planned Area. If the PCIG acquires any additional property that is not within the Master Planned Area then such future property may be added to this Agreement if the City determines that the addition of such future property is appropriate in light of its proximity to the Project compatibility and the appropriateness of such a development pattern.

22. Special Conditions.

22.1. WHSSD Agreement. This Agreement specifically incorporates the terms and obligations of three (3) separate agreements which are found to be in the public interest and are required as conditions of annexation of the PCIG Property to the City. The City has concluded an Agreement with the WHSSD providing for the transfer of the properties and facilities of the WHSSD to the City in return for the City assuming service obligations of the WHSSD. PCIG is not a party to this Agreement; however, the Parties acknowledge that the implementation and completion of all transfers required by the WHSSD Agreement are a condition of the City providing service to PCIG properties for future development. The WHSSD Agreement is attached to this Agreement as

Exhibit 10.

22.2 WHWC Transition Agreement. WHWC is a Public Service Commission regulated water utility which is presently under common management and control as the PCIG. The WHWC Transition Agreement with WHWC is attached to this Agreement as Exhibit 12. Completion of the transfers and obligations contemplated by the WHWC Transition Agreement with the City are a condition of the City issuing a development approval as set forth in the WHWC Transition Agreement, and of the City providing any service to PCIG, its properties or developments.

22.3 Local District Agreement. Pole Canyon Local District is a local district of the State of Utah which was formed as a result of an application filed by PCIG for the purpose of providing for the financing of certain public infrastructure within the PCIG Property as described more fully in this Agreement. The Local District Agreement with PCLD and compliance by PCLD with the terms of the Local District Agreement is a material consideration for the City entering this Agreement. PCLD and PCIG, with cooperation by the City where feasible and in the sole discretion of the Council, and as more fully provided in the Local District Agreement, are responsible for the implementation of a financing plan if approved by the City for the public facilities and infrastructure within the PCIG Property. In the event public facilities and infrastructure cannot be timely financed as provided in the Local District Agreement, the City may withhold further development approvals impacted by the applicable infrastructure to be financed until the financing plan is modified by PCIG and approved by the City and implemented.

23. Default.

23.1. Notice. If the PCIG or a Subdeveloper or the City fails to perform their respective obligations hereunder or to comply with the terms hereof, the party believing that a Default has occurred shall provide Notice to the other party. If the City believes that the Default has been committed by a Subdeveloper then the City shall also provide a courtesy copy of the Notice to the PCIG.

23.2. Contents of the Notice of Default. The Notice of Default shall:

23.2.1. Specify the claimed event of Default;

23.2.2. Identify with particularity the provisions of any applicable law, rule, regulation or provision of this Agreement that is claimed to be in Default;

23.2.3. Identify why the Default is claimed to be material; and

23.2.4. If the City chooses, in its discretion, propose a method and time for curing the Default which shall be of no less than sixty (60) days duration.

23.3. Remedies. If the parties are not able to resolve the Default through good faith negotiations or through mediation (which both parties agree to submit to upon the request of the other party), then the parties may have the following remedies:

23.3.1. All rights and remedies available at law and in equity, including, but not limited to, injunctive relief, specific performance

and/or damages.

23.3.2. The right to draw on any security posted or provided in connection with the Project and relating to remedying of the particular Default.

23.3.3. The right to withhold all further reviews, approvals, licenses, building permits and/or other permits for development of the Project in the case of a default by the PCIG, or in the case of a default by a Subdeveloper, development of those Parcels owned by the Subdeveloper until the Default has been cured.

23.3.4. If the cure of any alleged Default can be effectuated by the City because the alleged Default is covered by any security the City may have for the completion of a public improvement then the City may not declare a Default until it has attempted in good faith to use the security to remedy the alleged Default.

23.4. Notice and Public Meeting. Except for withholding the issuance of a building permit, before any remedy in Section 23.3 may be imposed by the City the party allegedly in Default shall be afforded the right to Notice of a public meeting before the Council and shall have the right to address the Council regarding the claimed Default.

23.5. Emergency Defaults. If the Council finds on the record that a default materially impairs a compelling, countervailing interest of the City, then the City may impose the remedies of Section 23.3 without meeting the negotiation and/or mediation requirements of Section 23.3.

23.6. Extended Cure Period. If any Default cannot be reasonably cured within sixty (60) days then such cure period shall be extended so long as the defaulting party is pursuing a cure with reasonable diligence.

24. Amendment. Any future amendments to this Agreement shall be in writing and signed by the PCIG (or a duly appointed agent of the PCIG, such as OWR) and a duly authorized representative of the City.

25. Assignability. The rights and responsibilities of the PCIG under this Agreement may be assigned in whole or in part by the PCIG, provided that the PCIG shall give Notice to the City of any assignment, and shall further provide such information regarding the assignee that the City may reasonably request. Such Notice shall include providing the City with all necessary contact information for the proposed assignee. If any proposed assignment is for less than all of the PCIG's rights and responsibilities then the assignee shall be responsible for the performance of each of the obligations contained in this Agreement to which the assignee succeeds. Upon any such partial assignment, the PCIG shall be released from any future obligations as to those obligations which are assigned but shall remain responsible for the performance of any obligations that were not assigned. Any assignee shall consent in writing to be bound by the assigned terms and conditions of this Agreement as a condition precedent to the effectiveness of the assignment.

26. Miscellaneous

26.1. Incorporation of Recitals, Exhibits. The above Recitals and attached Exhibits are hereby incorporated into this Agreement.

26.2. Binding Effect. A short-form notice of this Agreement shall be recorded by the PCIG and the City against the PCIG Property in substantially the form

attached as Exhibit 14 of the Pole Canyon Master Development Plan. This Agreement shall be deemed to run with the PCIG Property, and shall be binding upon and inure to the benefit of the successors, heirs and assigns of the parties hereto, and to any entities resulting from the reorganization, consolidation, or merger of any party hereto.

26.3. Notices. Any notices, requests and demands required or permitted to be given by any provision of this Agreement shall be in writing and shall be deemed to have been sufficiently given or served for all purposes if delivered personally to the party to whom the same is directed or three (3) days after being sent by United States mail, certified or registered mail, postage prepaid, addressed to such party's address set forth next to such party's signature below. Any party may change its address or notice by giving written notice to the other party in accordance with the provisions of this Section.

26.4. Headings. The headings contained in this Agreement are intended for convenience only and are in no way to be used to construe or limit the text herein.

26.5. Integration. This Agreement constitutes the entire understanding and agreement between the parties, and supersedes any previous agreement, representation, or understanding between the parties relating to the subject matter hereof.

26.6. Severability. If any part or provision of this Agreement shall be adjudged unconstitutional, invalid or unenforceable by a court or competent jurisdiction, then such a judgment shall not affect any other part or provision of this Agreement except that part or provision so adjudged to be unconstitutional, invalid or unenforceable. If any condition, covenant, or other provision of this

Agreement shall be deemed invalid due to its scope or breadth, such provision shall be deemed valid to the extent of the scope or breadth permitted by law.

26.7. Waiver. Any waiver by any party hereto of any breach of any kind or character what so ever by the other party, whether such waiver be direct or implied, shall not be construed as a continuing waiver of or consent to any subsequent breach of this Agreement on the part of the other part.

26.8. Governing Law. This Agreement shall be interpreted, construed and enforced according to the laws of the State of Utah.

26.9. Costs of Enforcement. In the event of default on the part of any party to this Agreement, that party shall be liable for all costs and expenses incurred by the other parties in enforcing the provisions of this Agreement, including but not limited to attorneys' fees, whether or not legal action is instituted.

26.10. Further Documentation. This Agreement is entered into by both parties with the recognition and anticipation that subsequent agreements implementing and carrying out the provisions of this Agreement may be necessary. The parties agree to negotiate in good faith with respect to all such future agreements.

26.11. Estoppel Certificate. If no default has occurred in the provisions of this Agreement and upon twenty (20) days prior written request by the PCIG or a Subdeveloper, the City will execute an estoppel certificate to any third party, certifying that the PCIG or a Subdeveloper, as the case may be, at that time is not in default of the terms of this Agreement.

26.12. No Joint Venture. This Agreement does not create a joint venture relationship, partnership or agency relationship between the City and the PCIG.

26.13. Mutual Drafting. Each party has participated in negotiating and drafting this Agreement and therefore no provision of this Agreement shall be construed for or against either party based on which party drafted any particular portion of this Agreement.

26.14. Authority. The parties to this Agreement each warrant that they have all of the necessary authority to execute this Agreement. Specifically, on behalf of the City, the signature of the Mayor of the City is affixed to this Agreement lawfully binding the City pursuant to and is further certified as to being lawful and binding on the City by the signature of the City Attorney.

[Signatures on Next Page.]

IN WITNESS WHEREOF, the parties have executed this Agreement by their authorized representatives effective as of the date first written above.

CITY:

EAGLE MOUNTAIN CITY, a Utah
municipal corporation

ATTEST:

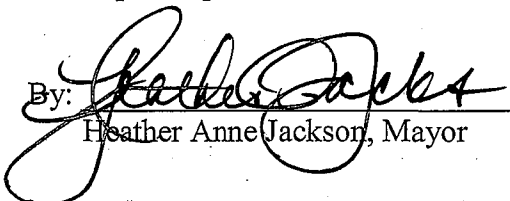
By: 
Heather Anne Jackson, Mayor

By: 
Fionnuala B. Kofoed, City Recorder



POLE CANYON INVESTMENT GROUP:

OQUIRRH WOOD RANCH, LLC, a
Utah limited liability company

GSJFJV, LLC, a Utah limited liability
company

By: Shipp Ventures, Inc., a Utah
corporation, its Manager

By: OQUIRRH WOOD RANCH, LLC, a Utah
limited liability company, its Manager

By: 

Nathan D. Shipp, President

By: Shipp Ventures, Inc., a Utah
corporation, its Manager

By: 

Nathan D. Shipp, President

1046624

{00085717.DOC /}

SCHEDULE ONE

DEFINED TERMS

As used in the Agreement, the words and phrases specified below shall have the following meanings:

Act means the Municipal Land Use Development and Management Act, Utah Code Ann. §§10-9a-101, et seq. (2008).

Agreement means this Annexation and Pole Canyon Master Development Agreement, including all of the Exhibits attached hereto.

Annexation Only Property has the meaning given to such term in the Recitals to this Agreement.

Annexation Property has the meaning given to such term in the Recitals to this Agreement.

Applicant means a person or entity submitting a Development Application or other land use application with the City in connection with the PCIG Property.

Backbone Infrastructure means those improvements shown as such in the Pole Canyon Infrastructure Plan and which are, generally, infrastructure improvements of a comprehensive scale that are a part of the overall development of the Annexed Property and not merely a part of the development of any particular Subdivision or Commercial Site. Backbone Infrastructure are generally considered to be in the nature of "System Improvements," as defined in Utah Code Ann. § 11-36-101, et seq. (2008).

Building Permit means a permit issued by the City to allow construction, erection or structural alteration of any building, structure, private or public infrastructure on-site infrastructure on any portion of the Project, or to construct any Off-Site Infrastructure.

Buildout means the completion of all of the development on all of the Project.

Business Park Planning Area has the meaning given to such term in the Recitals to this Agreement.

CC&R's means the Conditions, Covenants and Restrictions regarding certain aspects of design and construction on the PCIG Property to be recorded in the chain of title on all or a portion of the PCIG Property, and shall include the Master CC&R's and all "sub" CC&R's.

CUWCD means the Central Utah Water Conservancy District.

City means Eagle Mountain City, a Utah municipal corporation.

City Consultants means those outside consultants employed by the City in various specialized disciplines such as traffic, hydrology or drainage for reviewing certain aspects of the development of the Project.

City's Code means the Eagle Mountain Municipal Code, which was approved by the Council on October 7, 2008, as the same may be lawfully and properly amended from time to time.

Commercial Planning Area has the meaning given to such term in the Recitals to this Agreement.

Commercial Site means a portion of the Project which may include multiple buildings that are not intended to be on individual subdivision lots and includes apartments, shopping centers, business parks, or similar multi-building developments on portions of the Project for other commercial and/or industrial developments which are allowed by the applicable Zone as a permitted and/or conditional use.

Commercial Site Plan means the plan submitted to the City for the approval of the development of a Commercial Site.

Community Development Area, or CDA, has the meaning given to such term in Section 9.5.

Council means the elected City Council of the City.

Default means a material breach of this Agreement.

Denied means a formal denial issued by the final decision-making body of the City for a particular type of Development Application and does not include review comments or "redlines" by City staff.

Density means the number of Residential Dwelling Units allowed per acre in each Planning Area.

Design Review Committee shall be the committee authorized pursuant to the Technical Guidelines and/or Master CC&R's to consider and act upon all proposals or plans submitted pursuant to the Technical Guidelines. The Design Review Committee shall have such further rights and duties as are further set forth in the Technical Guidelines and Master CC&R's.

Development Application means an application to the City for development of a portion of the Project including a Subdivision, a Commercial Site, a Building Permit or any other permit, certificate or other authorization from the City required for development of the Project.

Development Report means a report containing the information specified in Sections 4.6 or 4.7 submitted to the City by the PCIG for the development by the PCIG of any Parcel or for the sale of any Parcel to a Subdeveloper or the submittal of a Development Application by a Subdeveloper pursuant to an assignment from the PCIG.

Economic Development Area, or EDA, has the meaning given to such term in Section 9.5 of this Agreement.

Existing Applicable Building Codes means building, plumbing, mechanical, electrical, dangerous buildings, drainage, or similar construction or safety related codes, such as the International Building Code and the Uniform Fire Code, that are generated by a nationally recognized construction/safety organization, or by the State or Federal governments and are required to alleviate legitimate and bona fide harmful and noxious uses.

Final Plat means the recordable map or other graphical representation of land

prepared in accordance with Utah Code Ann. § 10-9a-603 (2008), and approved by the City, effectuating a Subdivision of any portion of the Project.

General Development Standards means the general development standards relating to the improvement of the PCIG Property, as further set forth in the Technical Guidelines prepared and utilized by the PCIG in connection with the development of the Project, including without limitation, lot configuration, coverage, sizes and types, height limitations, setbacks, building sizes, streets and streetscapes, Open Space, landscaping, storm and other utility plans, lighting, parking, and signage.

Homeowners Association(s) means one or more associations formed pursuant to Utah law to perform the functions of an association of property owners.

Impact Fees means those fees, assessments, exactions or payments of money imposed by the City as a condition on development activity as specified in Utah Code Ann. § 11-36-101. *et seq.* (2008).

Intended Uses means the use of all or portions of the Project for single-family and multi-family residential units, institutional and special services, utility related services, automobile related uses, retail or related uses, industrial and related uses, open spaces, parks, trails and other uses, as more fully specified in the Pole Canyon Land Use Plan included as Exhibit 2 of the Pole Canyon Master Development Plan.

Local District Act means Utah Code Ann. § 17B-1-101 *et seq.* (2008).

Local District Agreement means the certain Agreement between the PCLD and the City, as referred to in Section 9.3 and attached as Exhibit 11.

Local Park means a park that is planned and designed as an amenity to serve and necessary for the use and convenience of a particular Planning Area (or a group of related Planning Areas) and which is not a System Improvement, but is counted towards the Open Space requirement set forth in the City's Code and Technical Guidelines.

Master CC&R's means the CC&R's to be recorded in the chain of title on the entire PCIG Property.

Master Planned Area has the meaning given to such term in the Recitals to this Agreement.

Maximum Residential Units means the development on the PCIG Property of a number of Residential Dwelling Units equal to the sum of all of the number of Residential Dwelling Units associated with each Neighborhood Planning Area for purposes of this Agreement, as further identified on the Pole Canyon Master Development Plan.

Neighborhood Planning Area has the meaning given to such term in the Recitals to this Agreement.

Non-City Agency means a governmental or quasi-governmental entity, other than those of the City, which has jurisdiction over the approval of any aspect of the Project, including without limitation, county or state governmental or quasi-governmental entities charged with oversight for transportation, health, safety, utilities, and so forth.

Notice means any notice to or from any party to this Agreement that is either required or permitted to be given to another party.

Off-Site Infrastructure means those items of public or private infrastructure which may be specified in the Pole Canyon Infrastructure Plan, and which are necessary for development of the PCIG Property such as roads, utilities, and other infrastructure and improvements set forth in Section 9.1, that are not on the site of any portion of the PCIG Property that is the subject of a Development Application.

On-Site Infrastructure means those items of public or private infrastructure specified in the Pole Canyon Infrastructure Plan or as a condition of the approval of a Development Application that are necessary for development of the PCIG Property, such as roads, utilities, and other infrastructure and improvements set forth in Section 9.1, that are located on that portion of the PCIG Property which is subject to a Development Application.

Open Space means those areas, whether publicly or privately owned, (a) without any buildings or other physical improvements, except those customary and/or necessary to

the provision of recreation and those permitted by the City's Code and/or Technical Guidelines, as applicable, (b) any natural break that provides appropriate breaks from building masses or conserves or preserves natural, historic or other amenities with social or cultural values, or (c) which maintain the natural water table level or preserves wetlands. Open Space includes, but is not limited to, those areas identified as Open Space in the Pole Canyon Master Development Plan and/or Technical Guidelines.

Open Space Report means a report containing the information specified in Section 8.5 submitted to the City by the PCIG for the development by the PCIG of any Parcel or for the sale of any Parcel to a Subdeveloper or the submittal of a Development Application by a Subdeveloper pursuant to an assignment from the PCIG.

OWR means Oquirrh Wood ranch, LLC, a Utah limited liability company.

Parcel means a portion of a Planning Area located within the PCIG Property which is intended to be developed as a particular type of Intended Use.

PCIG means the Pole Canyon Investment Group, and its respective assignees or transferees as permitted by this Agreement.

Petition for Annexation has the meaning given to such term in the Recitals set forth above, and includes the petition(s) filed by the PCIG for purposes of initiating the annexation of the Annexation Property into the City.

Phase means the development of a portion of the Project at a point in a logical sequence as determined by the PCIG.

Planning Area has the meaning given to such term in the Recitals to this Agreement.

Pole Canyon Infrastructure Plan means the portion of the Pole Canyon Master Development Plan identified as the "Pole Canyon Infrastructure Plan," which plan is adopted simultaneously with this Agreement, and shows the Backbone Infrastructure for the PCIG Property, including water, roads, and other infrastructure.

Pole Canyon Local District (or PCLD) means the local district to be formed in accordance with Section 9.3 of this Agreement.

Pole Canyon Master Development Plan means, as further defined in the Recitals to this Agreement, the plan comprising this Agreement and the Exhibits to this Agreement, as the master plan approved by the City in connection with this Agreement and the development of the PCIG Property.

PCIG Property means, as set forth in the Recitals to this Agreement, the approximately two thousand six hundred (2,600) acres either owned or controlled by the PCIG which are a part of Annexed Property and which are more fully described in Exhibit 3.

Project means the development to be constructed on the PCIG Property pursuant to this Agreement with the associated public and private facilities, Intended Uses, Densities, Phases and all of the other aspects approved as part of this Agreement including its Exhibits.

Public Infrastructure and Improvements has the meaning given to such term in Section 9.1 of this Agreement.

Regional Park means a park identified in the City's capital facilities plan, and that is intended to provide services to the community at large such that it would be considered to be a System Improvement. Without limiting the generality of the foregoing, the rodeo grounds contemplated by this Agreement to be constructed on the PCIG Property are expressly included within the definition of a Regional Park.

Residential Dwelling Unit means, for purposes of calculating Density, a unit intended to be occupied for residential living purposes: one single-family residential dwelling and each separate unit in a multi-family dwelling, apartment building, condominium or time-share equals one Residential Dwelling Unit.

SAA means Special Assessment Areas created in accordance with the the SAA Act.

SAA Act means Utah Code Ann. § 11-42-101 *et seq.* (2008).

Site Plan means the plan submitted to the City for the first stage of the approval of a Subdivision or Commercial Development.

Special Assessment Area or SAA means an area or areas to be created as set forth in Section 9.4 pursuant to State Law, for the purpose of funding the construction of some or all of the On-Site Infrastructure and/or the Off-Site Infrastructure.

Subdeveloper means an entity not "related" (as defined by Internal Revenue Service regulations) to the PCIG which purchases a Parcel for development.

Subdivision means the division of any portion of the Project into a subdivision pursuant to procedures set forth under State Law and/or the City's Code.

Subdivision Application means the application to create a Subdivision.

Subdivision Site Plan means the plan submitted with a Subdivision Application.

Substantial Completion means a point in the progress of a construction project where the work has reached the point that it is sufficiently complete such that any remaining work will not interfere with the intended use or occupancy of the project. For work to be substantially complete it is not required that the work be 100% complete.

System Improvement means those elements of infrastructure that are defined as System Improvements pursuant to Utah Code Ann. §11-3-6-102(16) (2008).

Technical Guidelines means those General Development Standards and other guidelines created, implemented, amended and enforced by the PCIG in connection with the Project.

White Hills Subdivision has the meaning given to such term in the Recitals to this Agreement.

WHSSD means White Hills Special Service District.

WHSSD Agreement means the certain Agreement between the PCLD, WHSSD,

and the City, as referred to in Section 9.3 and attached as Exhibit 10.

WHWC means White Hills Water Company, a Utah corporation.

WHWC System Repairs has the meaning given to such term in Section 9.4.1 of this Agreement.

WHWC Transition Agreement means the certain Agreement between the WHWC and the City, as referred to in Section 16.2 and attached as Exhibit 12.

SCHEDULE TWO

Pole Canyon Master Development Plan– Summary of Exhibits

Exhibit 1 – Annexation Property / Annexation Petitions

Exhibit 2 – Master Planned Area / Land Use Element

Exhibit 3 – PCIG Property

Exhibit 4 – Density Allocation

Exhibit 5 – Wet Utility Master Plan

Exhibit 6 – Dry Utility Master Plan

Exhibit 7 – Traffic Impact Study

Exhibit 8 – Open Space and/or Trails

Exhibit 9 – Local District Maps

Exhibit 10 – WHSSD Agreement

Exhibit 11 – Local District Agreement

Exhibit 12 – WHWC Transition Agreement

Exhibit 13 – Additional Exhibits/Maps

Exhibit 14 – Short-Form Notice of Agreement

Exhibit 1 – Annexation Property/Annexation Petitions

Petition for Annexation

We the undersigned owners of certain real property lying contiguous to the present municipal limits of Eagle Mountain City hereby submit this Petition for Annexation and respectfully represent the following:

1. That this petition is made pursuant to the requirements of Section 10-2-403, Utah Code Annotated, 1953, as amended (U.C.A.);
2. That the property subject to this petition is a contiguous, unincorporated area contiguous to the boundaries of Eagle Mountain City and the annexation thereof will not leave or create an unincorporated island or peninsula;
3. That the signatures affixed hereto are those of the owners of private real property that:
 - a. Is located within the area proposed for annexation
 - b. covers a majority of the private land area within the area proposed for annexation;
 - c. is equal in value to at least 1/3 of the value of all private real property within the area proposed for annexation; and
 - d. is described as follows:

The property subject of this petition lies contiguous to the present boundary of Eagle Mountain City corporate limits (describe approximate location) _____

More specifically described as follows (legal description):

See attached exhibit "Pole Canyon No. 1 Addition"

4. That up to five of the signers of this petition have been designated as sponsors, one of whom is designated as the "Contact Sponsor", with the mailing address of each sponsor being indicated;
5. That this petition does not propose annexation of all or a part of an area proposed for annexation in a previously filed petition that has not been denied, rejected, or granted.
6. That this petition does not propose annexation of an area that includes some or all of an area proposed to be incorporated in a request for feasibility study under Section 10-2-103 U.C.A. or a petition under Section 10-2-125 U.C.A.

The petitioners further file herewith two (2) copies of an accurate and recordable map or plat, of the certain real property sought to be annexed which the petitioners have caused to be prepared by _____ a licensed surveyor.

SPONSERS OF PETITION:

NAME

ADDRESS

CONTACT SPONSOR:

Oquirrh Woods Ranch, LLC
 By: Shipp Ventures
 Its: Manager

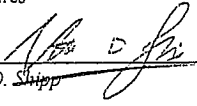
 By: Nathan D. Shipp
 Its: President

Phone No. 801-495-3414
 GSFJU, LLC

Its: Manager
 By: Oquirrh Woods Ranch, LLC
 Its: Manager
 By: Shipp Ventures, Inc.
 Its: Manager

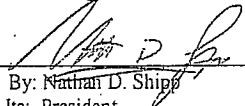

 By: Nathan D. Shipp
 Its: President

1099 W. South Jordan Pkwy
South Jordan UT 84095

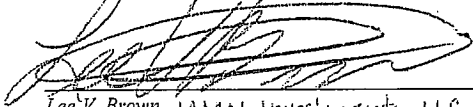
1099 W. South Jordan Pkwy
South Jordan UT 84095

 Lee V. Brown MMN Investments, LLC
 Manager

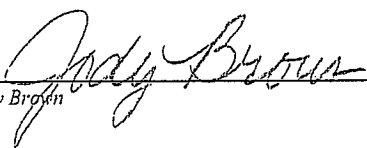
PO Box 230
Cedar Valley, UT 84013

 Jody Brown

2921 N. Hwy 73
Cedar Valley, UT 84013

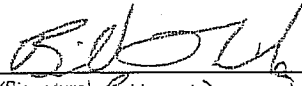
 (Signature) BILL WILSON

3819 N CEDAR VALLEY HWY
CEAR FORT UT 84013

STATE OF UTAH)
 Sittles)
 COUNTY OF UTAH)

On the 2nd day of July, 20 , personally appeared before me,

Lee Van Brown, Jody B Brown
Nathan D. Shipp, William H. Wilson

the signers of the foregoing instrument, who duly acknowledged to me that they executed the same.

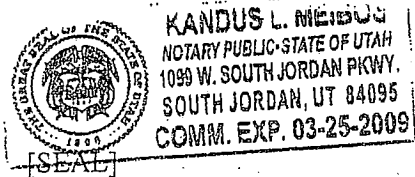

Kandus L. Meibos
Notary Public

My commission expires: 3/25/2009

SPONSERS OF PETITION:

NAME

ADDRESS

CONTACT SPONSOR:

(Signature of Contact Sponsor)

Phone No. _____

Grant Smith
(Signature) Grant Smith Farms, LLC

18489 Wilson Ave
Cedar Valley, UT 84013

Grant Smith
(Signature)

90 No. 500 West
Hehi, UT 84043

Brent Bowles
(Signature)

3967 So. 1460 West
West Valley City, UT 84123

R. Blaine Bowles
(Signature)

3944 PHARAOH CIR.
WVC, UT 84123

STATE OF UTAH)

South Lakes
COUNTY OF UTAH)

On the 7th day of August, 2008, personally appeared before me,

Grant B Smith, Carey Grant Smith

Brent Bowles, Robert Blaine Bowles

the signers of the foregoing instrument, who duly acknowledged to me that they executed the same.

Kandus L. Meibos

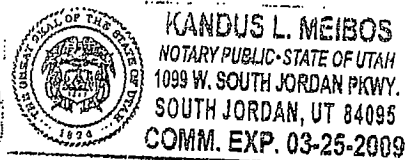

3/25/2009

[SEAL]

Notary Public
My commission expires: 3/25/09

Petition for Annexation

We the undersigned owners of certain real property lying contiguous to the present municipal limits of Eagle Mountain City hereby submit this Petition for Annexation and respectfully represent the following:

1. That this petition is made pursuant to the requirements of Section 10-2-403, Utah Code Annotated, 1953, as amended (U.C.A.);
2. That the property subject to this petition is a contiguous, unincorporated area contiguous to the boundaries of Eagle Mountain City and the annexation thereof will not leave or create an unincorporated island or peninsula;
3. That the signatures affixed hereto are those of the owners of private real property that:
 - a. Is located within the area proposed for annexation
 - b. covers a majority of the private land area within the area proposed for annexation;
 - c. is equal in value to at least 1/3 of the value of all private real property within the area proposed for annexation; and
 - d. is described as follows:

The property subject of this petition lies contiguous to the present boundary of Eagle Mountain City corporate limits (describe approximate location) _____

More specifically described as follows (legal description):

See attached exhibit "Pole Canyon No. 2 Addition"

4. That up to five of the signers of this petition have been designated as sponsors, one of whom is designated as the "Contact Sponsor", with the mailing address of each sponsor being indicated;
5. That this petition does not propose annexation of all or a part of an area proposed for annexation in a previously filed petition that has not been denied, rejected, or granted.
6. That this petition does not propose annexation of an area that includes some or all of an area proposed to be incorporated in a request for feasibility study under Section 10-2-103 U.C.A. or a petition under Section 10-2-125 U.C.A.

The petitioners further file herewith two (2) copies of an accurate and recordable map or plat, of the certain real property sought to be annexed which the petitioners have caused to be prepared by _____ a licensed surveyor.

SPONSERS OF PETITION:

NAME

ADDRESS

CONTACT SPONSOR:

Oquirrh Woods Ranch, LLC

Its: Manager

By: Shipp Ventures

Nathan D. Shipp

Its: Presiden

Phone No. 801-495-3414

1099 W. South Jordan Pkwy

S. Jordan, UT 84095

(Signature)

(Signature)

(Signature)

(Signature)

STATE OF UTAH)

:§

COUNTY OF UTAH)

On the _____ day of _____, 20____, personally appeared before me,

_____, _____,

_____, _____,

the signers of the foregoing instrument, who duly acknowledged to me that they executed the same.

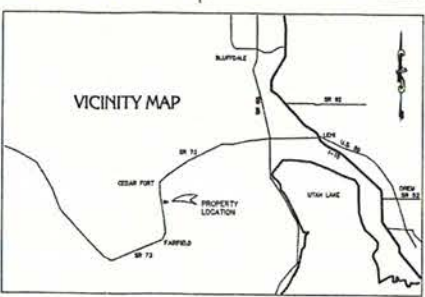
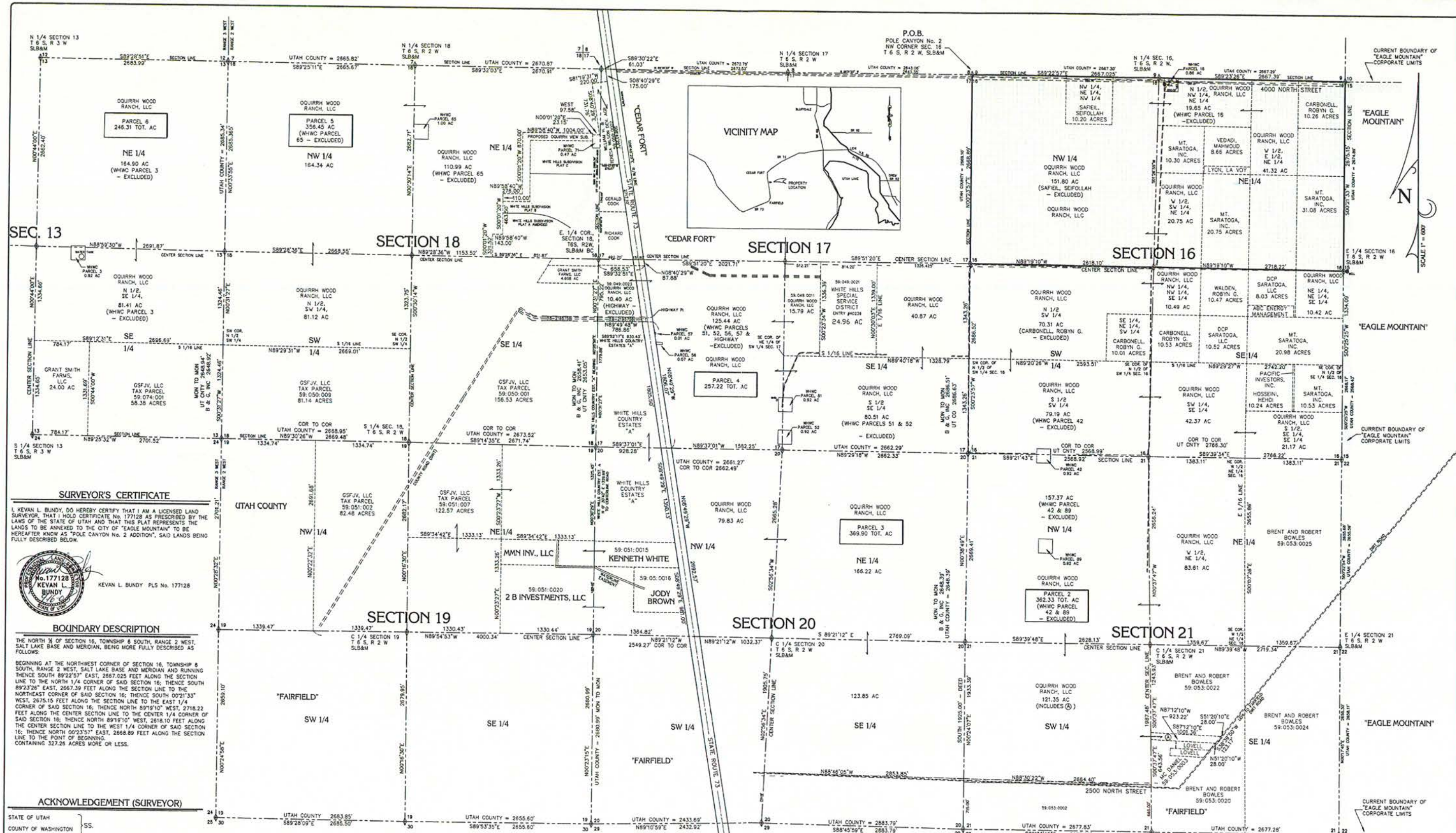

SURVEYOR'S CERTIFICATE
 I, KEVAN L. BUNDY, DO HEREBY CERTIFY THAT I AM A LICENSED LAND SURVEYOR THAT I HOLD CERTIFICATE NO. 177128 AS PRESCRIBED BY THE LAWS OF THE STATE OF UTAH AND THAT THIS PLAN REPRESENTS THE LANDS TO BE ANNEXED TO THE CITY OF "EAGLE MOUNTAIN" TO BE HEREAFTER KNOWN AS "POLE CANYON No. 2 ADDITION", SAID LANDS BEING FULLY DESCRIBED BELOW.



BOUNDARY DESCRIPTION
 THE NORTH 1/4 OF SECTION 16, TOWNSHIP 6 SOUTH, RANGE 2 WEST, SALT LAKE BASE AND MERIDIAN, BEING MORE FULLY DESCRIBED AS FOLLOWS:
 BEGINNING AT THE NORTHWEST CORNER OF SECTION 16, TOWNSHIP 6 SOUTH, RANGE 2 WEST, SALT LAKE BASE AND MERIDIAN AND RUNNING THENCE SOUTH 89°22'57" EAST, 2667.025 FEET ALONG THE SECTION LINE TO THE NORTH 1/4 CORNER OF SAID SECTION 16; THENCE SOUTH 89°22'28" EAST, 2667.39 FEET ALONG THE SECTION LINE TO THE NORTHEAST CORNER OF SAID SECTION 16; THENCE SOUTH 02°21'13" WEST, 2675.15 FEET ALONG THE SECTION LINE TO THE EAST 1/4 CORNER OF SAID SECTION 16; THENCE NORTH 89°19'10" WEST, 2718.22 FEET ALONG THE CENTER SECTION LINE TO THE CENTER 1/4 CORNER OF SAID SECTION 16; THENCE NORTH 89°19'10" WEST, 2718.22 FEET ALONG THE CENTER SECTION LINE TO THE CENTER 1/4 CORNER OF SAID SECTION 16; THENCE SOUTH 02°21'13" WEST, 2675.15 FEET ALONG THE SECTION LINE TO THE POINT OF BEGINNING. CONTAINING 327.26 ACRES MORE OR LESS.

ACKNOWLEDGEMENT (SURVEYOR)

STATE OF UTAH)
 COUNTY OF WASHINGTON) SS.
 ON THIS 16th DAY OF SEPTEMBER, 2008, BEFORE ME PERSONALLY APPEARED KEVAN L. BUNDY, WHOSE IDENTITY IS PERSONALLY KNOWN TO ME OR PROVED TO ME ON THE BASIS OF SATISFACTORY EVIDENCE, AND WHO, BEING BY ME DULY SWORN (OR AFFIRMED), DID SAY THAT HE IS THE PERSON WHOSE NAME IS SIGNED ON THE FOREGOING SURVEYOR'S CERTIFICATE, AND ACKNOWLEDGED BEFORE ME THAT HE SIGNED IT VOLUNTARILY FOR THE USES AND PURPOSES STATED THEREIN.

NOTARY PUBLIC
 RESIDING IN WASHINGTON COUNTY, STATE OF UTAH
 MY COMMISSION EXPIRES: 5/12/2010

RYAN LEE
 NOTARY PUBLIC-STATE OF UTAH
 109 WEST SUNSET BLVD.
 ST. GEORGE, UT 84778
 COMM. EXP. 03-13-2010

LEGEND
 POLE CANYON No. 2 ADDITION
 WHWC = WHITE HILLS WATER CONVS. PROP.

NOTES
 1. THIS PLAN WAS CREATED USING THE A.L.T.A. SURVEY COMPLETED BY BUSH & QUIGLEY INC. WHICH IS TITLED "WHITE AND SMITH PROPERTIES" AND DATED 06-01-08.

BUNDY SURVEYING INCORPORATED
 1704 WEST SUNSET BLVD., ST. GEORGE, UTAH 84770
 PHONE: (435) 619-1990
 SURVEY LOCATION: SECTIONS 16 & 17, T6S, R2W, SLBAM
 MAP DATE: SEPTEMBER 15, 2008

ACCEPTANCE BY THE LEGISLATIVE BODY

WE, THE DULY ELECTED COUNCIL OF THE CITY OF EAGLE MOUNTAIN, UTAH, HAVE RECEIVED A REQUEST TO INITIATE PROCEDURES FOR THE ANNEXATION OF THE TRACT OF LAND SHOWN HEREON, WHICH TRACT CONSTITUTES A PORTION OF AN EXISTING ISLAND OR PENINSULA WITHIN OR CONTIGUOUS TO THE CITY, AND DO HEREBY CERTIFY: (1) THE COUNCIL HAS ADOPTED A RESOLUTION SETTING FORTH ITS INTENT TO ANNEX THE TRACT, PROVIDED NOTICE AND CONDUCTED HEARINGS ON THE MATTER, AND ADOPTED AN ORDINANCE PROVIDING FOR THE ANNEXATION OF THE LAND SHOWN HEREON AS A PART OF EAGLE MOUNTAIN CITY, TO BE KNOWN HERE AFTER AS THE POLE CANYON No. 2 ADDITION.

DATED THIS _____ DAY OF _____, 200__.

CLERK RECORDER

EAGLE MOUNTAIN ANNEXATION PETITION
POLE CANYON No. 2 ADDITION

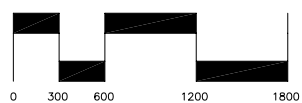
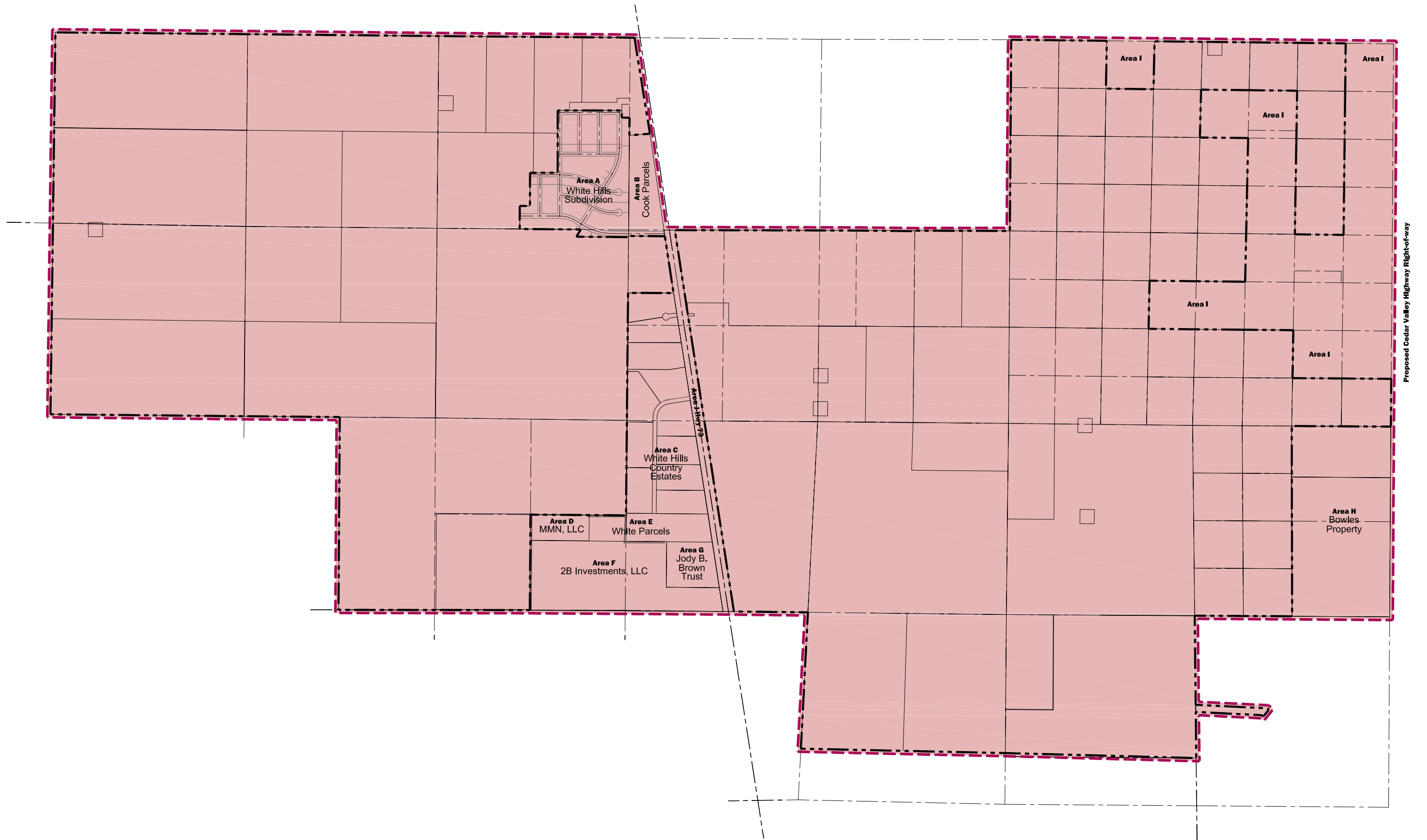

Annexation Boundary



Annexation Property Exhibit 1



Exhibit 2 – Master Planned Area/Land Use Element

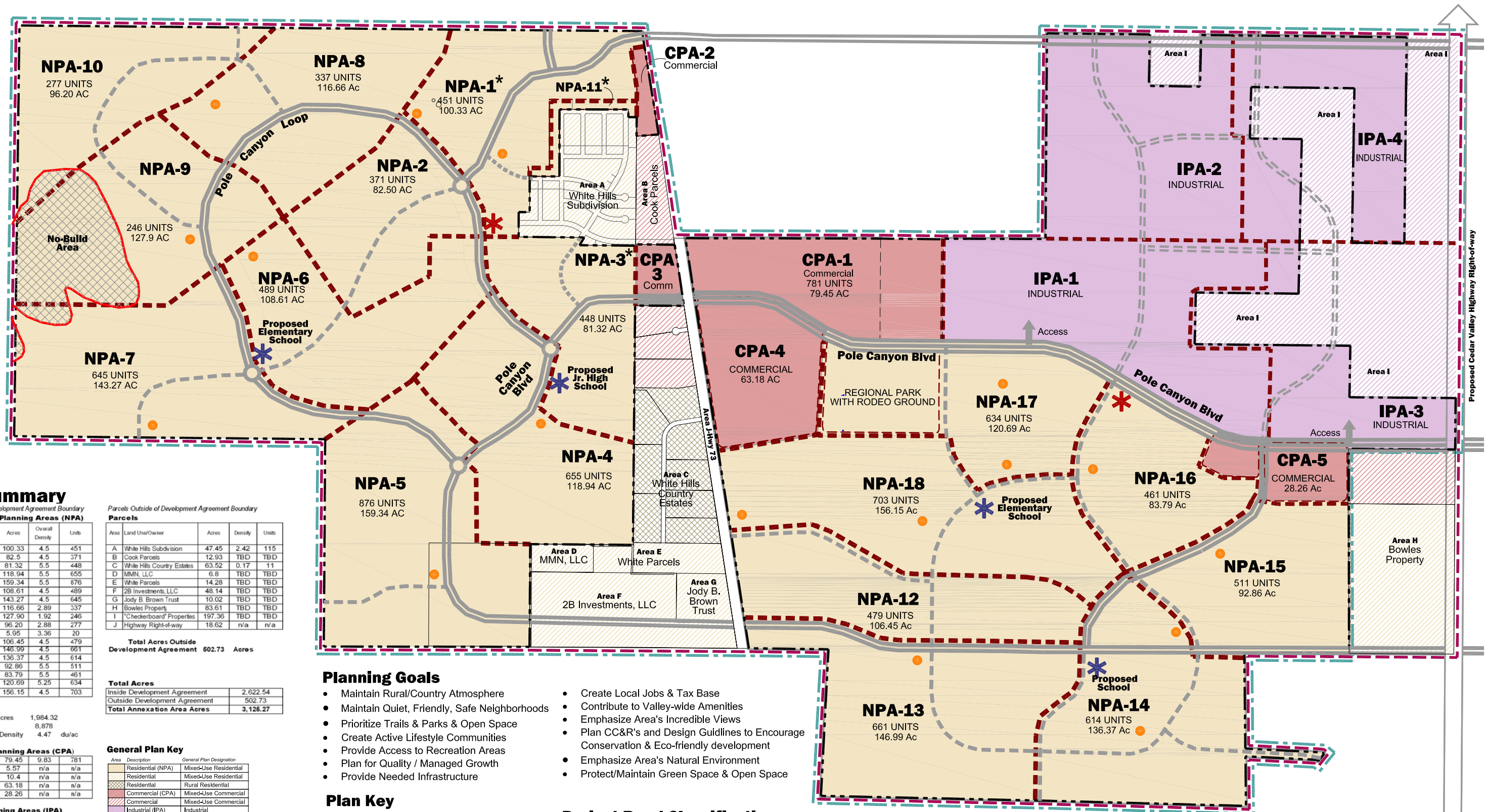

Site Summary

Parcels Inside of Development Agreement Boundary
Neighborhood Planning Areas (NPA)

| Area | Planning Area Type | Acres | Overall Density | Units |
|------|--------------------|--------|-----------------|-------|
| 1 | Residential | 100.33 | 4.5 | 451 |
| 2 | Residential | 82.5 | 4.5 | 371 |
| 3 | Residential | 81.32 | 5.5 | 448 |
| 4 | Residential | 118.94 | 5.5 | 655 |
| 5 | Residential | 159.34 | 5.5 | 876 |
| 6 | Residential | 108.61 | 4.5 | 489 |
| 7 | Residential | 143.27 | 4.5 | 645 |
| 8 | Residential | 116.66 | 2.89 | 337 |
| 9 | Residential | 127.90 | 1.92 | 246 |
| 10 | Residential | 96.20 | 2.88 | 277 |
| 11 | Residential | 5.95 | 3.36 | 20 |
| 12 | Residential | 106.45 | 4.5 | 479 |
| 13 | Residential | 146.99 | 4.5 | 661 |
| 14 | Residential | 136.37 | 4.5 | 614 |
| 15 | Residential | 92.86 | 5.5 | 511 |
| 16 | Residential | 83.79 | 5.5 | 461 |
| 17 | Residential | 120.69 | 5.25 | 634 |
| 18 | Residential | 156.15 | 4.5 | 703 |

Total Residential Acres 1,984.32
Total Units 8,878
Residential Gross Density 4.47 du/ac

Commercial Planning Areas (CPA)

| Area | Description | Acres | Density | Units |
|------|-------------|-------|---------|-------|
| 1 | Commercial | 79.45 | 9.83 | 781 |
| 2 | Commercial | 5.57 | n/a | n/a |
| 3 | Commercial | 10.4 | n/a | n/a |
| 4 | Commercial | 63.18 | n/a | n/a |
| 5 | Commercial | 28.26 | n/a | n/a |

Industrial Planning Areas (IPA)

| Area | Description | Acres | Density | Units |
|------|-------------|--------|---------|-------|
| 1 | Industrial | 159.9 | n/a | n/a |
| 2 | Industrial | 142.04 | n/a | n/a |
| 3 | Industrial | 57.09 | n/a | n/a |
| 4 | Industrial | 92.33 | n/a | n/a |

Total Dev Agreement Acres 2,622.54
Total Residential Units 9,659
Gross Density 3.68

Parcels Outside of Development Agreement Boundary
Parcels

| Area | Land Use/Owner | Acres | Density | Units |
|------|-----------------------------|--------|---------|-------|
| A | White Hills Subdivision | 47.45 | 2.42 | 115 |
| B | Cook Parcels | 12.93 | TBD | TBD |
| C | White Hills Country Estates | 63.52 | 0.17 | 11 |
| D | MMN, LLC | 6.8 | TBD | TBD |
| E | White Parcels | 14.28 | TBD | TBD |
| F | 2B Investments, LLC | 48.14 | TBD | TBD |
| G | Jody B. Brown Trust | 10.02 | TBD | TBD |
| H | Bowles Property | 83.61 | TBD | TBD |
| I | "Checkerboard" Properties | 197.36 | TBD | TBD |
| J | Highway Right-of-way | 18.62 | n/a | n/a |

Total Acres Outside Development Agreement 502.73 Acres

Total Acres

| | |
|------------------------------------|-----------------|
| Inside Development Agreement | 2,622.54 |
| Outside Development Agreement | 502.73 |
| Total Annexation Area Acres | 3,125.27 |

General Plan Key

| Area | Description | General Plan Designation |
|-------------------|-----------------------|--------------------------|
| Residential (NPA) | Mixed-Use Residential | |
| Residential | Mixed-Use Residential | |
| Residential | Rural Residential | |
| Commercial (CPA) | Mixed-Use Commercial | |
| Commercial | Mixed-Use Commercial | |
| Industrial (IPA) | Industrial | |
| Industrial | Industrial | |

* Note: In NPA 11, all lots shall be a min 10,000 Sq Ft. In NPA 1 & 3, a street with min 10,000 Sq Ft lots on both sides shall about the existing White Hills Subdivision

Planning Goals

- Maintain Rural/Country Atmosphere
- Maintain Quiet, Friendly, Safe Neighborhoods
- Prioritize Trails & Parks & Open Space
- Create Active Lifestyle Communities
- Provide Access to Recreation Areas
- Plan for Quality / Managed Growth
- Provide Needed Infrastructure
- Create Local Jobs & Tax Base
- Contribute to Valley-wide Amenities
- Emphasize Area's Incredible Views
- Plan CC&R's and Design Guidelines to Encourage Conservation & Eco-friendly development
- Emphasize Area's Natural Environment
- Protect/Maintain Green Space & Open Space

Plan Key

- Planning Area Boundary
- ★ Proposed Schools
- ✳ Proposed Public Safety Facility

Project Road Classifications

- === Arterial Road Corridors
- == Major Collector Road Corridors
- === Industrial Collector Road Corridors
- Minor Collector Road Corridors
- Local Street

Boundary Classifications

- Annexation Boundary
- Development Agreement Boundary
- Master Plan Area

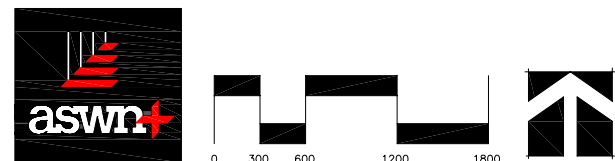

Land Use Element Exhibit 2



Exhibit 3 – PCIG Property

BOUNDARY DESCRIPTIONS

LAND LYING IN SECTION 16, THE SOUTH 1/4 SECTION 17, SECTION 18, THE NORTH 1/4 SECTION 19, THE NW 1/4, THE NE 1/4 AND THE SE 1/4 SECTION 20 AND IN SECTION 21, TOWNSHIP 6 SOUTH, RANGE 2 WEST, SALT LAKE BASE AND MERIDIAN, AND IN THE EAST 1/2 OF SECTION 13, TOWNSHIP 6 SOUTH, RANGE 3 WEST, SALT LAKE BASE AND MERIDIAN, DESCRIBED AS FOLLOWS:

BEGINNING AT THE NORTHEAST CORNER OF SECTION 18, TOWNSHIP 6 SOUTH, RANGE 2 WEST, SALT LAKE BASE & MERIDIAN, AND RUNNING SOUTH 89°30'22" EAST, 61.03 FEET ALONG THE SECTION LINE TO THE WESTERLY RIGHT-OF-WAY LINE OF STATE ROUTE NO. 73; THENCE SOUTH 08°40'29" EAST, 175.00 FEET ALONG SAID RIGHT-OF-WAY LINE; THENCE LEAVING SAID RIGHT-OF-WAY LINE AND RUNNING ALONG THE BOUNDARY LINE OF THE WILLIAM H. AND TERESA WILSON PROPERTY (DEVELOPMENT AGREEMENT) IN THE FOLLOWING TWO COURSES: SOUTH 81°19'31" WEST, 220.00 FEET; THENCE SOUTH 08°40'29" EAST, 731.76 FEET TO THE NORTH BOUNDARY LINE OF THE WHITE HILLS WATER CONSERVANCY PROPERTY; THENCE WEST 97.58 FEET ALONG SAID NORTH BOUNDARY LINE; THENCE NORTH 00°01'20" EAST, 23.15 FEET; THENCE NORTH 89°58'40" WEST, 1004.00 FEET; THENCE SOUTH 00°01'20" WEST, 870.00 FEET; THENCE NORTH 89°58'40" WEST, 276.00 FEET; THENCE SOUTH 00°01'20" WEST, 110.00 FEET TO THE WEST BOUNDARY LINE OF "WHITE HILLS SUBDIVISION PLAT B"; THENCE SOUTH 00°01'20" WEST, 163.52 FEET ALONG SAID WEST BOUNDARY LINE TO THE WEST BOUNDARY LINE OF "WHITE HILLS SUBDIVISION PLAT A AMENDED"; THENCE ALONG THE WEST AND SOUTH BOUNDARY OF SAID SUBDIVISION IN THE FOLLOWING NINE COURSES: SOUTH 00°01'20" WEST, 300.00 FEET; THENCE NORTH 89°58'40" W, 143.00 FEET; THENCE SOUTH 00°01'20" WEST, 321.15 FEET; THENCE SOUTH 89°28'47" EAST, 851.85 FEET; THENCE SOUTH 31°31'20" WEST, 117.29 FEET; THENCE SOUTH 89°28'47" EAST, 208.45 FEET; THENCE NORTH 00°01'20" EAST, 66.13 FEET TO A POINT ON THE ARC OF A 742.11 FOOT RADIUS CURVE TO THE LEFT, THE BEARING TO RADIUS POINT BEING NORTH 21°33'06" EAST; THENCE EASTERLY 273.40 FEET ALONG THE ARC OF SAID CURVE THROUGH A CENTRAL ANGLE OF 21°06'30" TO THE POINT OF TANGENCY; THENCE SOUTH 89°33'23" EAST, 909.98 FEET ALONG SAID SUBDIVISION BOUNDARY LINE AND THE PROLONGATION THEREFROM TO THE EASTERLY RIGHT-OF-WAY LINE OF "STATE ROUTE NO. 73"; THENCE NORTH 08°40'29" WEST, 87.54 FEET ALONG SAID RIGHT-OF-WAY LINE TO A POINT ON THE EAST-WEST CENTER SECTION LINE OF SECTION 17, TOWNSHIP 6 SOUTH, RANGE 2 WEST, SALT LAKE BASE & MERIDIAN; THENCE SOUTH 89°51'20" EAST, 2021.71 FEET ALONG SAID CENTER SECTION LINE TO THE CENTER 1/4 CORNER OF SAID SECTION 17; THENCE SOUTH 89°51'20" EAST, 512.21 FEET ALONG THE CENTER SECTION LINE TO THE WEST BOUNDARY LINE OF THE "WHITE HILLS SPECIAL SERVICE DISTRICT" PROPERTY RECORDED AS ENTRY # 040239-1986, IN THE OFFICE OF THE RECORDER FOR UTAH COUNTY, STATE OF UTAH; THENCE ALONG THE BOUNDARY LINE OF SAID PROPERTY IN THE FOLLOWING THREE COURSES: SOUTH 00°23'34" WEST, 1336.39 FEET TO THE SOUTH 1/16 LINE; THENCE SOUTH 89°40'18" EAST, 811.68 FEET ALONG THE SOUTH 1/16 LINE; THENCE NORTH 00°30'03" EAST, 1339.00 FEET TO THE CENTER SECTION LINE; THENCE SOUTH 89°51'20" EAST, 1326.43 FEET ALONG THE CENTER SECTION LINE TO THE EAST 1/4 CORNER OF SAID SECTION 17; THENCE NORTH 00°23'57" EAST, 2668.89 FEET ALONG THE SECTION LINE TO THE NORTHWEST CORNER OF SECTION 16, TOWNSHIP 6 SOUTH, RANGE 2 WEST, SALT LAKE BASE & MERIDIAN; THENCE SOUTH 89°22'57" EAST, 1333.51 FEET ALONG THE SECTION LINE TO THE WEST BOUNDARY OF THE "SAFIEIL" PROPERTY, SERIAL NO. 59:048:007; THENCE ALONG SAID BOUNDARY IN THE FOLLOWING THREE COURSES: SOUTH 00°55'27" WEST, 667.69 FEET; THENCE SOUTH 89°22'01" EAST, 663.70 FEET; THENCE NORTH 01°11'12" EAST, 667.79 FEET TO THE SECTION LINE; THENCE SOUTH 89°22'57" EAST, 666.76 FEET TO THE NORTH 1/4 CORNER OF SAID SECTION 16; THENCE SOUTH 89°23'26" EAST, 2000.54 FEET TO THE NORTHEAST CORNER OF THE NORTHWEST 1/4 OF THE NORTHEAST 1/4 OF THE NORTHEAST 1/4 OF SAID SECTION 16; THENCE SOUTH 00°37'53" WEST, 2674.28 FEET TO THE SOUTHEAST CORNER OF THE SOUTHWEST 1/4 OF THE SOUTHEAST 1/4 OF THE NORTHEAST 1/4 OF SAID SECTION 16; THENCE NORTH 89°19'10" WEST, 679.55 FEET ALONG THE CENTER SECTION LINE TO THE SOUTHWEST CORNER OF THE SOUTHWEST 1/4 OF THE SOUTHEAST 1/4 OF THE NORTHEAST 1/4 OF SAID SECTION 16; THENCE NORTH 00°54'13" EAST, 2005.11 FEET TO THE SOUTHEAST CORNER OF THE NORTHEAST 1/4 OF THE NORTHWEST 1/4 OF THE NORTHEAST 1/4 OF SAID SECTION 16; THENCE NORTH 89°22'21" WEST, 1340.05 FEET TO THE NORTHWEST CORNER OF THE SOUTHWEST 1/4 OF THE NORTHWEST 1/4 OF THE NORTHEAST 1/4 OF SAID SECTION 16; THENCE SOUTH 01°26'55" WEST, 668.01 FEET TO THE SOUTHWEST CORNER OF THE SOUTHWEST 1/4 OF THE NORTHEAST 1/4 OF SAID SECTION 16; THENCE SOUTH 89°21'16" EAST, 673.20 FEET TO THE SOUTHEAST CORNER OF THE SOUTHWEST 1/4 OF THE NORTHWEST 1/4 OF THE NORTHEAST 1/4 OF SAID SECTION 16; THENCE SOUTH 01°10'34" WEST, 1336.36 FEET TO THE SOUTHEAST CORNER OF THE SOUTHWEST 1/4 OF THE SOUTHWEST 1/4 OF THE NORTHEAST 1/4 OF SAID SECTION 16; THENCE SOUTH 01°11'37" WEST, 670.14 FEET TO THE SOUTHEAST CORNER OF THE NORTHWEST 1/4 OF THE NORTHWEST 1/4 OF THE SOUTHEAST 1/4 OF SAID SECTION 16; THENCE NORTH 89°24'20" WEST, 682.55 FEET TO THE SOUTHWEST CORNER OF THE NORTHWEST 1/4 OF THE NORTHWEST 1/4 OF THE SOUTHEAST 1/4 OF SAID SECTION 16; THENCE NORTH 89°19'47" WEST, 651.45 FEET TO THE NORTHWEST CORNER OF THE SOUTHEAST 1/4 OF THE NORTHEAST 1/4 OF THE SOUTHWEST 1/4 OF SAID SECTION 16; THENCE SOUTH 01°11'10" WEST, 671.29 FEET TO THE SOUTHWEST CORNER OF THE SOUTHEAST 1/4 OF THE NORTHEAST 1/4 OF THE SOUTHWEST 1/4 OF SAID SECTION 16; THENCE SOUTH 89°20'26" EAST, 648.38 FEET TO THE SOUTHEAST CORNER OF THE SOUTHEAST 1/4 OF THE NORTHEAST 1/4 OF THE SOUTHWEST 1/4 OF SAID SECTION 16; THENCE SOUTH 89°29'27" EAST, 1371.10 FEET TO THE NORTHEAST CORNER OF THE NORTHEAST 1/4 OF THE SOUTHWEST 1/4 OF THE SOUTHEAST 1/4 OF SAID SECTION 16; THENCE SOUTH 00°58'16" WEST, 889.10 FEET TO THE SOUTHEAST CORNER OF THE NORTHEAST 1/4 OF THE SOUTHWEST 1/4 OF THE SOUTHEAST 1/4 OF SAID SECTION 16; THENCE SOUTH 89°34'32" EAST, 1377.10 FEET TO THE NORTHEAST CORNER OF THE SOUTHEAST 1/4 OF THE SOUTHEAST 1/4 OF THE SOUTHWEST 1/4 OF SAID SECTION 16; THENCE SOUTH 00°25'25" WEST, 867.04 FEET ALONG THE SECTION LINE TO THE SOUTHEAST CORNER OF SAID SECTION 16; THENCE NORTH 89°39'34" WEST, 1383.11 FEET ALONG THE SECTION LINE TO THE NORTHEAST CORNER OF THE NORTHWEST 1/4 OF THE NORTHEAST 1/4 OF SECTION 21, TOWNSHIP 6 SOUTH, RANGE 2 WEST, SALT LAKE BASE & MERIDIAN; THENCE SOUTH 00°07'26" EAST, 2655.86 FEET ALONG THE EAST 1/16 LINE TO THE SOUTHEAST CORNER OF THE SOUTHWEST 1/4 OF THE NORTHEAST 1/4 OF SAID SECTION 21; THENCE NORTH 89°39'48" WEST, 1359.67 FEET ALONG THE EAST-WEST CENTER SECTION LINE TO THE CENTER 1/4 OF SAID SECTION 21; THENCE SOUTH 00°37'47" EAST, 1243.93 FEET ALONG THE CENTER SECTION LINE; THENCE SOUTH 87°12'10" EAST, 1001.36 FEET TO THE WEST BOUNDARY LINE OF THE LEHI TO FAIRFIELD ROAD; THENCE SOUTH 51°20'10" EAST, 28.00 FEET TO THE CENTERLINE OF SAID ROAD; THENCE SOUTH 38°39'50" WEST, 123.17 FEET ALONG SAID CENTERLINE; THENCE NORTH 51°20'10" WEST, 28.00 FEET TO THE WEST BOUNDARY LINE OF SAID ROAD; THENCE NORTH 87°12'10" WEST, 923.22 FEET TO THE CENTER SECTION LINE; THENCE SOUTH 00°37'47" EAST, 643.56 FEET ALONG THE CENTER SECTION LINE TO THE NORTH BOUNDARY LINE OF 2500 NORTH STREET; THENCE LEAVING THE CENTER SECTION LINE AND RUNNING NORTH 88°30'22" WEST, 2664.40 FEET ALONG SAID NORTH BOUNDARY LINE TO THE WEST LINE OF THE SOUTHWEST 1/4 OF SAID SECTION 21, BEING THE EAST LINE OF THE SOUTHEAST 1/4 OF SECTION 20, TOWNSHIP 6 SOUTH, RANGE 2 WEST, SALT LAKE BASE & MERIDIAN, THENCE NORTH 88°46'05" WEST, 2853.85 FEET TO THE NORTH-SOUTH CENTER SECTION LINE OF SAID SECTION 20; THENCE NORTH 02°56'34" EAST, 1905.75 FEET ALONG THE SECTION LINE TO THE CENTER 1/4 CORNER OF SAID SECTION 20; THENCE NORTH 89°21'12" WEST, 2549.27 FEET ALONG THE EAST-WEST CENTER SECTION LINE TO THE EAST 1/4 CORNER OF SAID SECTION 20; THENCE NORTH 89°54'53" WEST, 4000.34 FEET ALONG THE EAST-WEST CENTER SECTION LINE OF SECTION 19, TOWNSHIP 6 SOUTH, RANGE 2 WEST, SALT LAKE BASE & MERIDIAN TO THE SOUTHWEST CORNER OF THE SOUTHEAST 1/4 OF THE NORTHWEST 1/4 OF SAID SECTION 19; THENCE NORTH 00°22'32" EAST, 2691.68 FEET TO THE NORTHWEST CORNER OF THE NORTHEAST 1/4 OF THE NORTHWEST 1/4 OF SAID SECTION 19; THENCE NORTH 89°30'26" WEST, 1334.74 FEET ALONG THE SECTION LINE TO THE NORTHWEST CORNER OF SAID SECTION 19; THENCE NORTH 89°25'32" WEST, 2701.52 FEET ALONG THE SOUTH LINE OF SECTION 13, TOWNSHIP 6 SOUTH, RANGE 3 WEST, SALT LAKE BASE & MERIDIAN TO THE SOUTH 1/4 CORNER OF SAID SECTION 13; THENCE NORTH 00°44'00" EAST, 5331.71 FEET ALONG THE NORTH-SOUTH CENTER SECTION LINE TO THE NORTH 1/4 CORNER OF SAID SECTION 13; THENCE SOUTH 89°28'51" EAST, 2683.99 FEET ALONG THE SECTION LINE TO THE NORTHEAST CORNER OF SAID SECTION 13; THENCE SOUTH 89°25'11" EAST, 2665.67 FEET ALONG THE NORTH LINE OF SECTION 18, TOWNSHIP 6 SOUTH, RANGE 2 WEST, SALT LAKE BASE & MERIDIAN TO THE NORTH 1/4 CORNER OF SAID SECTION 18; THENCE SOUTH 89°32'03" EAST, 2670.91 FEET ALONG THE SECTION LINE TO THE POINT OF BEGINNING. CONTAINING 2,746.51 ACRES MORE OR LESS.

Exhibit 3:
PCIG Property
Pole Canyon Development

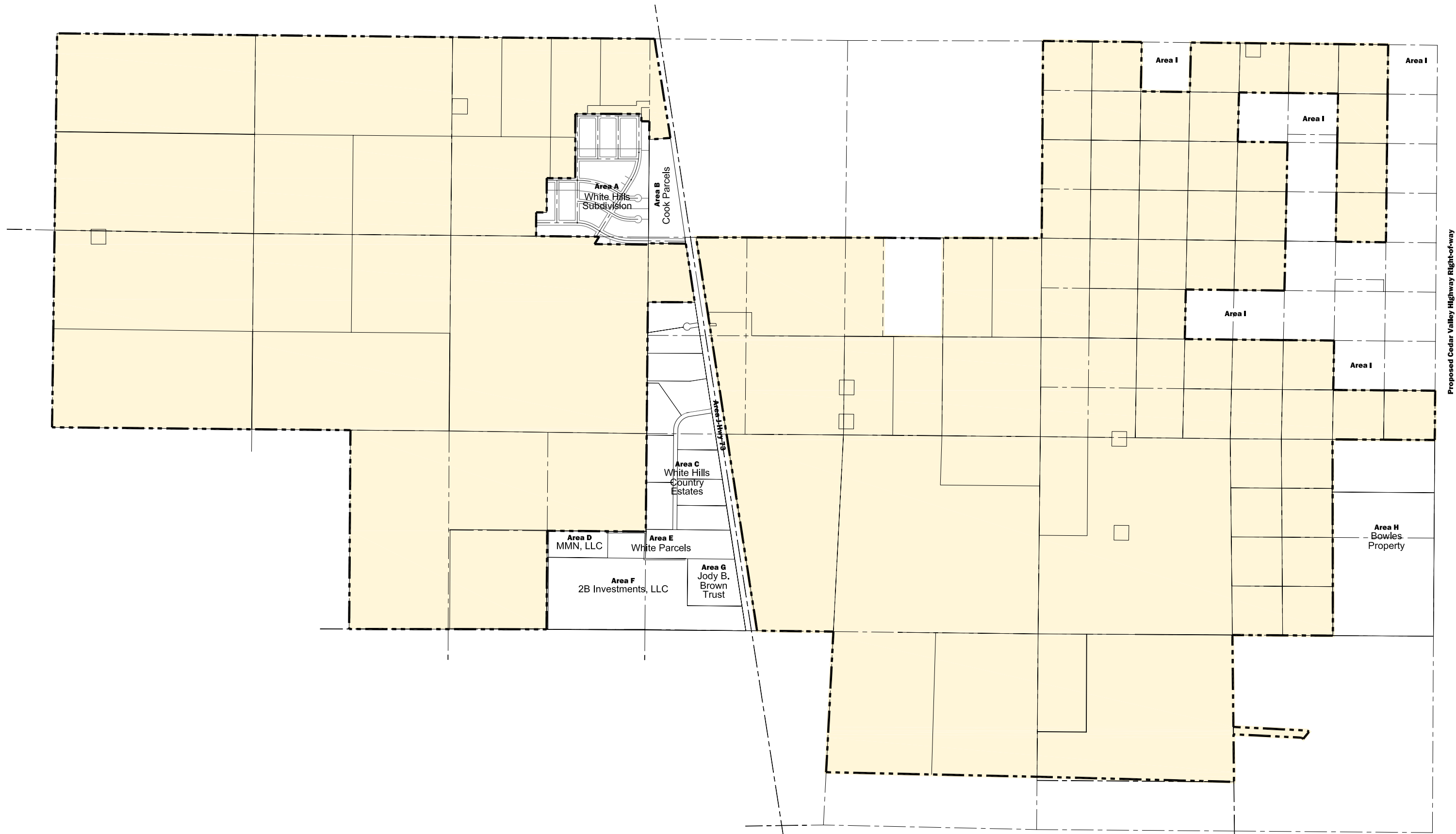

Proposed Cedar Valley Highway Right-of-way

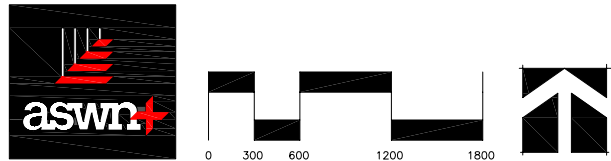

PCIG Property Exhibit 3



Exhibit 4 – Density Allocation

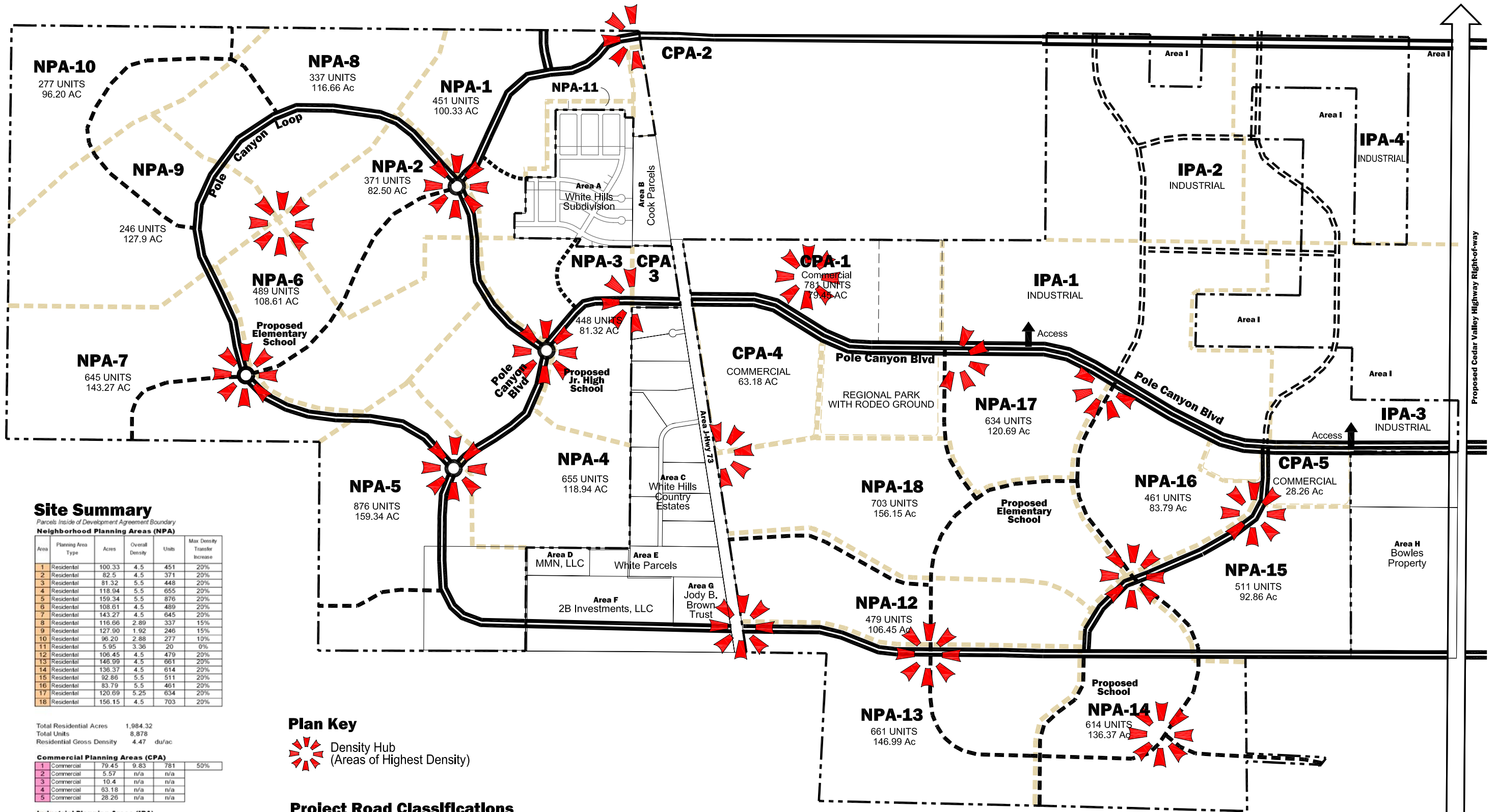

Site Summary

Parcels Inside of Development Agreement Boundary

Neighborhood Planning Areas (NPA)

| Area | Planning Area Type | Acres | Overall Density | Units | Max Density Transfer Increase |
|------|--------------------|--------|-----------------|-------|-------------------------------|
| 1 | Residential | 100.33 | 4.5 | 451 | 20% |
| 2 | Residential | 82.5 | 4.5 | 371 | 20% |
| 3 | Residential | 81.32 | 5.5 | 448 | 20% |
| 4 | Residential | 118.94 | 5.5 | 655 | 20% |
| 5 | Residential | 159.34 | 5.5 | 876 | 20% |
| 6 | Residential | 108.61 | 4.5 | 489 | 20% |
| 7 | Residential | 143.27 | 4.5 | 645 | 20% |
| 8 | Residential | 116.66 | 2.89 | 337 | 15% |
| 9 | Residential | 127.90 | 1.92 | 246 | 15% |
| 10 | Residential | 96.20 | 2.88 | 277 | 10% |
| 11 | Residential | 5.95 | 3.36 | 20 | 0% |
| 12 | Residential | 106.45 | 4.5 | 470 | 20% |
| 13 | Residential | 146.99 | 4.5 | 661 | 20% |
| 14 | Residential | 136.37 | 4.5 | 614 | 20% |
| 15 | Residential | 92.86 | 5.5 | 511 | 20% |
| 16 | Residential | 83.79 | 5.5 | 461 | 20% |
| 17 | Residential | 120.69 | 5.25 | 634 | 20% |
| 18 | Residential | 156.15 | 4.5 | 703 | 20% |

Total Residential Acres 1,984.32
 Total Units 8,878
 Residential Gross Density 4.47 du/ac

Commercial Planning Areas (CPA)

| Area | Planning Area Type | Acres | Overall Density | Units | Max Density Transfer Increase |
|------|--------------------|-------|-----------------|-------|-------------------------------|
| 1 | Commercial | 79.45 | 9.83 | 781 | 50% |
| 2 | Commercial | 5.57 | n/a | n/a | n/a |
| 3 | Commercial | 10.4 | n/a | n/a | n/a |
| 4 | Commercial | 63.18 | n/a | n/a | n/a |
| 5 | Commercial | 28.26 | n/a | n/a | n/a |

Industrial Planning Areas (IPA)

| Area | Planning Area Type | Acres | Overall Density | Units | Max Density Transfer Increase |
|------|--------------------|--------|-----------------|-------|-------------------------------|
| 1 | Industrial | 159.9 | n/a | n/a | n/a |
| 2 | Industrial | 142.04 | n/a | n/a | n/a |
| 3 | Industrial | 130.49 | n/a | n/a | n/a |
| 4 | Industrial | 154.44 | n/a | n/a | n/a |

Total Dev Agreement Acres 2,758.05
 Total Residential Units 9,659
 Gross Density 3.50

Plan Key

Density Hub (Areas of Highest Density)

Project Road Classifications

- Arterial Road Corridors
- Major Collector Road Corridors
- Industrial Collector Road Corridors
- Minor Collector Road Corridors
- Local Street

Boundary Classifications

- Planning Area Boundaries
- Property



Density Allocation Exhibit 4



Proposed Cedar Valley Highway Right-of-way

Exhibit 5 – Wet Utility Master Plan

Wet Utilities Master Plan

For

Pole Canyon Development

Cedar Valley, Utah

Project by



August 2008

Revised: November 9, 2009



POLE CANYON

DEMOGRAPHICS

Table of Contents

| | |
|--------------------------------|----------|
| TABLE OF CONTENTS | 1 |
| DEMOGRAPHICS | 2 |
| INTRODUCTION | 2 |
| LAND USE | 2 |
| GROWTH DISTRIBUTION | 2 |
| POPULATION..... | 4 |
| PLANNING UNITS | 6 |
| FUTURE GROWTH | 6 |

Introduction

Pole Canyon is a proposed residential development located in Cedar Valley, Utah west of Eagle Mountain, Utah and situated at the mouth of Pole Canyon. The ultimate build-out plan for Pole Canyon includes more than 2,600 acres consisting of numerous land use categories from low-density residential to light industrial. The existing subdivisions of White Hills and White Hills Country Estates will be included as part of Pole Canyon and the existing utilities in these subdivisions will be expanded and improved to provide for proposed future growth.

Land Use

Figure 1 on the following page shows the proposed types and locations of land uses (zoning) as part of Pole Canyon. The primary land use types are Neighborhood Planning Areas, Mixed-use Planning Area, Commercial Planning Areas, Business Park Planning Areas, and Open Space. Conceptual land use planning was completed by ASWN Planners. The planning goals for the development include preserving the quiet, rural atmosphere of the area while providing for quality, managed growth and creation of local jobs and valley-wide amenities.

Growth Distribution

Growth and development within Pole Canyon will take a phased approach with areas near existing utility infrastructure developing first. In order to determine utility infrastructure requirements, Equivalent Residential Connections (ERC) were estimated based on density values provided by ASWN Planners. Densities and estimated ERC are shown on Figure 1. The resulting residential ERC values (were multiplied by 3.5 persons per ERC (typical of Northern Utah) to estimate total population. This analysis allowed both the evaluation of site specific and growth related infrastructure requirements for the undeveloped areas and the projection of the build-out population for Pole Canyon. The resulting build-out population for Pole Canyon was estimated to be 33,800 with approximately 15,476 ERCs as shown in Table 1. The existing development of White Hills contributes 424 persons and 121 ERC for a total of 34,224 persons and 15,597 ERC. Obviously, development and growth will occur over a number of years in a managed phased approach with infrastructure requirements and utilities being constructed in a timely manner to allow for this growth.

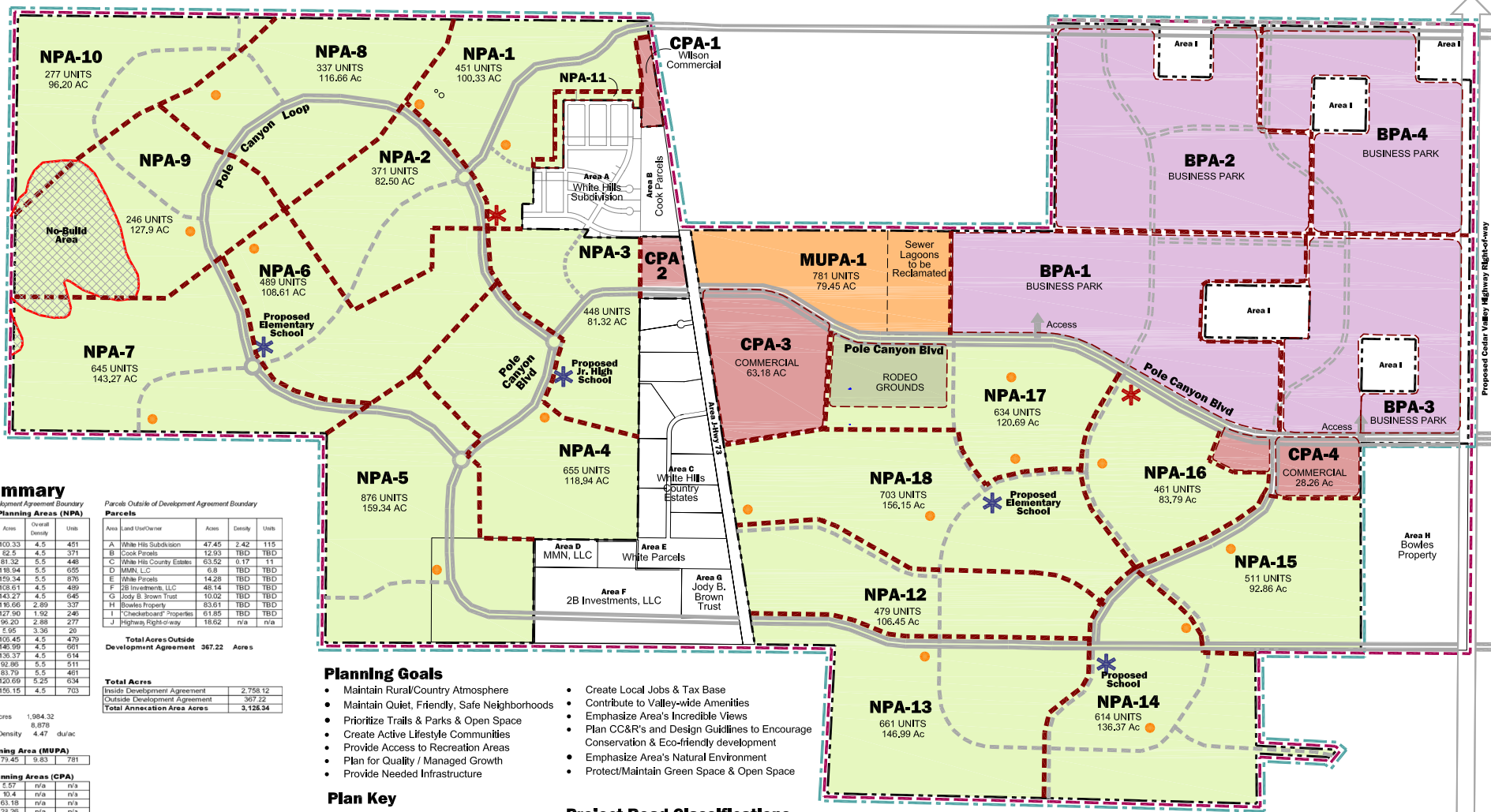

Site Summary

Neighborhood Planning Areas (NPA)

| Area | Planning Area | Type | Acres | Overall Density | Units |
|------|---------------|--------|-------|-----------------|-------|
| 1 | Residential | 100.33 | 4.5 | 451 | |
| 2 | Residential | 82.5 | 4.5 | 371 | |
| 3 | Residential | 81.32 | 5.5 | 448 | |
| 4 | Residential | 118.94 | 5.5 | 655 | |
| 5 | Residential | 159.34 | 5.5 | 876 | |
| 6 | Residential | 108.61 | 4.5 | 489 | |
| 7 | Residential | 143.27 | 4.5 | 645 | |
| 8 | Residential | 116.66 | 2.89 | 337 | |
| 9 | Residential | 127.90 | 1.92 | 246 | |
| 10 | Residential | 96.20 | 2.88 | 277 | |
| 11 | Residential | 100.33 | 3.30 | 20 | |
| 12 | Residential | 108.45 | 4.5 | 479 | |
| 13 | Residential | 146.95 | 4.5 | 661 | |
| 14 | Residential | 136.37 | 4.5 | 614 | |
| 15 | Residential | 92.86 | 5.5 | 511 | |
| 16 | Residential | 93.79 | 5.5 | 461 | |
| 17 | Residential | 120.69 | 5.25 | 634 | |
| 18 | Residential | 156.15 | 4.5 | 703 | |

Parcels Outside of Development Agreement Boundary

| Area | Land Use/Owner | Acres | Density | Units |
|------|-----------------------------|-------|---------|-------|
| A | White Hills Subdivision | 47.45 | 2.42 | 115 |
| B | Cook Parcels | 12.93 | TBD | TBD |
| C | White Hills Country Estates | 63.52 | 0.17 | 11 |
| D | MMN, LLC | 6.8 | TBD | TBD |
| E | White Parcels | 14.28 | TBD | TBD |
| F | 2B Investments, LLC | 48.14 | TBD | TBD |
| G | Jody B. Brown Trust | 10.02 | TBD | TBD |
| H | Bowles Property | 83.61 | TBD | TBD |
| I | Checkboard Properties | 61.85 | TBD | TBD |
| J | Highway Right-of-way | 18.62 | n/a | n/a |

Total Acres Outside Development Agreement 367.22 Acres

Total Acres

| | |
|------------------------------------|-----------------|
| Inside Development Agreement | 2,756.12 |
| Outside Development Agreement | 367.22 |
| Total Annexation Area Acres | 3,123.34 |

Mixed-use Planning Area (MUPA)

| | | | |
|-------------|-------|------|-----|
| 1 Mixed Use | 79.45 | 9.63 | 781 |
|-------------|-------|------|-----|

Commercial Planning Areas (CPA)

| | | | |
|---------------------|-------|-----|-----|
| 1 Wilson Commercial | 10.4 | n/a | n/a |
| 2 Comm / Retail | 10.4 | n/a | n/a |
| 3 Comm / Retail | 63.18 | n/a | n/a |
| 4 Comm / Retail | 28.26 | n/a | n/a |

Business Park Planning Areas (BPA)

| | | | |
|-----------------|--------|-----|-----|
| 1 Business Park | 113.28 | n/a | n/a |
| 2 Business Park | 133.18 | n/a | n/a |
| 3 Business Park | 129.04 | n/a | n/a |
| 4 Business Park | 154.44 | n/a | n/a |

Total Dev Agreement Acres 2,756.12
Total Residential Units 9,659
Gross Density 3.50

Planning Goals

- Maintain Rural/Country Atmosphere
- Maintain Quiet, Friendly, Safe Neighborhoods
- Prioritize Trails & Parks & Open Space
- Create Active Lifestyle Communities
- Provide Access to Recreation Areas
- Plan for Quality / Managed Growth
- Provide Needed Infrastructure
- Create Local Jobs & Tax Base
- Contribute to Valley-wide Amenities
- Emphasize Area's Incredible Views
- Plan CC&R's and Design Guidelines to Encourage Conservation & Eco-friendly development
- Emphasize Area's Natural Environment
- Protect/Maintain Green Space & Open Space

Plan Key

- Planning Area Boundary
- ★ Proposed Schools
- ★ Proposed Public Safety Facility
- Potential Church Site

Church sites will be located throughout each planning area on an as-needed basis

Project Road Classifications

- Arterial Road Corridors
- Major Collector Road Corridors
- Industrial Collector Road Corridors
- Minor Collector Road Corridors
- Local Street

Boundary Classifications

- Annexation Boundary
- Development Agreement Boundary
- Master Plan Area

Land Use Plan Exhibit 2

Proposed Final Draft
August 10, 2009

Table 1 – Buildout ERC and Population Projection

| Neighborhood Planning Areas (NPA) | | | | |
|--------------------------------------------|---------------------|--------|-----------------|-------------|
| Planning Area | Planning Area Type | Acres | Overall Density | Total Units |
| 1 | Residential | 100.33 | 4.5 | 451 |
| 2 | Residential | 82.5 | 4.5 | 371 |
| 3 | Residential | 81.32 | 5.5 | 447 |
| 4 | Residential | 118.94 | 5.5 | 654 |
| 5 | Residential | 159.34 | 5.5 | 876 |
| 6 | Residential | 108.61 | 4.5 | 489 |
| 7 | Residential | 143.27 | 4.5 | 645 |
| 8 | Residential | 116.66 | 2.89 | 337 |
| 9 | Residential | 127.9 | 1.92 | 246 |
| 10 | Residential | 96.2 | 2.88 | 277 |
| 11 | Residential | 5.95 | 3.36 | 20 |
| 12 | Residential | 106.45 | 4.5 | 479 |
| 13 | Residential | 146.99 | 4.5 | 661 |
| 14 | Residential | 136.37 | 4.5 | 614 |
| 15 | Residential | 92.86 | 5.5 | 511 |
| 16 | Residential | 83.79 | 5.5 | 461 |
| 17 | Residential | 120.69 | 5.25 | 634 |
| 18 | Residential | 156.15 | 4.5 | 703 |
| Mixed-use Planning Area (MUPA) | | | | |
| 1 | Mixed Use | 65.09 | 12 | 781 |
| *Commercial Planning Areas (CPA) | | | | |
| 1 | Wilson Commercial | 5.57 | 5 | 28 |
| 2 | Commercial / Retail | 10.4 | 5 | 52 |
| 3 | Commercial / Retail | 63.18 | 5 | 316 |
| 4 | Commercial / Retail | 28.26 | 5 | 141 |
| *Business Park Planning Areas (BPA) | | | | |
| 1 | Business Park | 170.28 | 9 | 1533 |
| 2 | Business Park | 133.18 | 9 | 1199 |
| 3 | Business Park | 129.04 | 9 | 1161 |
| 4 | Business Park | 154.44 | 9 | 1390 |
| Total Units | | | | 15,476 |
| Total Acres | | | | 2,743.8 |
| Gross Density | | | | 5.47 |

**Densities for CPA and BPA areas are estimates and not provided by ASWN Planners, but recommendations by Horrocks Engineers.*

Population

Because Pole Canyon is a new community without existing population data or building permit information, the nearby cities of Eagle Mountain and Saratoga Springs were studied. Census data for these cities show that from 2000-2006 yearly growth rates of up to 972% were recorded with average annual rates of change (AARC) of 48.5%. It is anticipated that Pole Canyon will experience similar growth for the first 5 years. Future population projections from the Utah Office of Planning and Budget (UOPB) and MAG show these cities having long-term growth rates of 7.50% and 9.07% respectively. Based on this information, an AARC estimate of 45% will be applied to Pole Canyon for the first 6 years beginning in 2008 and decreasing by 5% per year until the long-term growth rate for Eagle Mountain of 7.50% has been reached.

After reviewing the available data Table 2 was generated. This table represents an estimated population growth rate similar to existing communities in the Cedar Valley with a long-term growth rate equal to that of Eagle Mountain, Utah as provided by the UOPB. The resulting population estimate was discussed with the developers and determined to fit their development plans. It is also representative of the expected growth rates of Eagle Mountain, Utah. As shown, the build-out population is expected to be 34,224 in the year 2030.

Figure 2 was generated to graphically show the projection and the resulting estimated population of Pole Canyon from 2008 to Build-out.

Table 2 – Pole Canyon Population Projections

| Year | Population | Growth Rate | Year | Population | Growth Rate |
|------|------------|-------------|-------------|---------------|-------------|
| 2008 | 424 | 45.00% | 2020 | 14,316 | 15.00% |
| 2009 | 615 | 45.00% | 2021 | 16,463 | 10.00% |
| 2010 | 891 | 45.00% | 2022 | 18,110 | 10.00% |
| 2011 | 1,293 | 45.00% | 2023 | 19,921 | 10.00% |
| 2012 | 1,874 | 45.00% | 2024 | 21,913 | 9.00% |
| 2013 | 2,718 | 45.00% | 2025 | 23,885 | 9.00% |
| 2014 | 3,941 | 35.00% | 2026 | 26,035 | 8.00% |
| 2015 | 5,320 | 30.00% | 2027 | 28,115 | 7.50% |
| 2016 | 6,916 | 25.00% | 2028 | 30,223 | 7.50% |
| 2017 | 8,645 | 20.00% | 2029 | 32,490 | 7.50% |
| 2018 | 10,374 | 20.00% | 2030 | 34,224 | Build-out |
| 2019 | 12,449 | 15.00% | | | |

Figure 2 – Population Growth

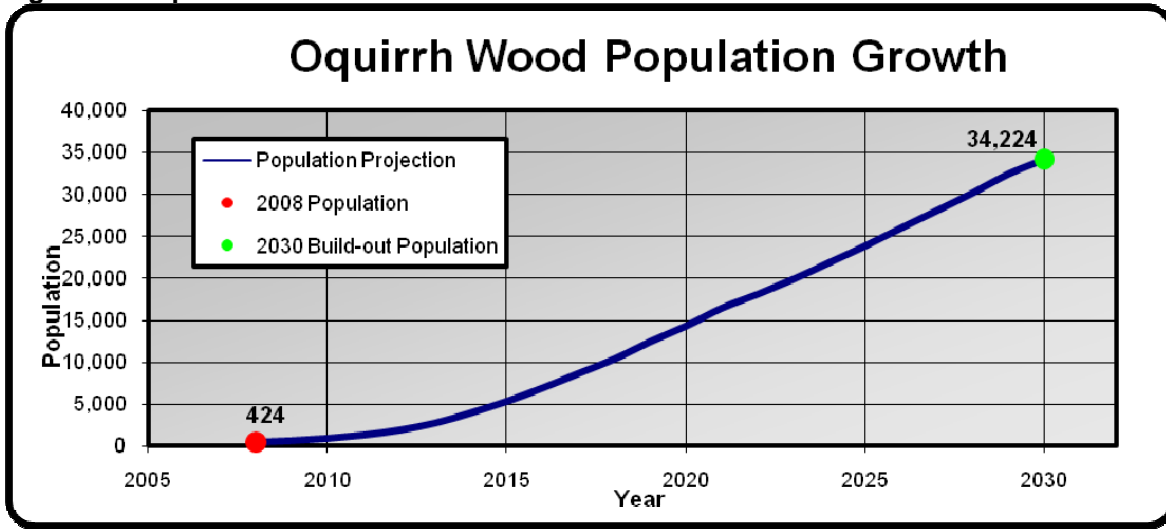

Planning Units

For utility master planning efforts, the preferred planning unit is the Equivalent Residential Connection (ERC). One ERC represents a single family dwelling with known utility demands. Because this development is new with relatively few existing homes, ERC were determined using housing densities as provided by ASWN Planners. Typically, actual service connections are less than ERC and a factor often used for this conversion is 1.15 ERC per service connection. Pole Canyon is projected to have approximately 15,476 ERC at build-out or 13,458 service connections.

Future Growth

To allocate future growth for infrastructure analysis, it is necessary to convert the build-out population projection into ERC. The only existing infrastructure within the Pole Canyon boundary is the White Hills Water Company utility. This system serves approximately 121 homes, all of which are single family residences and therefore constitute 121 ERC. Table 4 is a summary of current and future utility requirements based on ERC. All upgrades are system upgrades and should be attributable to growth and thus impact fee eligible.

Table 3 – Equivalent Residential Connections

| Pole Canyon Equivalent Residential Connections | | | | | |
|------------------------------------------------|--------|------------|-----|------------|--------|
| Total | | Current | | Future | |
| Population | ERC | Population | ERC | Population | ERC |
| 34,224 | 15,597 | 424 | 121 | 33,800 | 15,476 |

References

Mountainland Association of Governments – 2007
Municipalities, Counties – Population Projections Utah Office of Planning and Budget

**POLE CANYON
STORM DRAINAGE ANALYSIS**

Table of Contents

| | |
|-------------------------------------------------|----|
| Table of Contents | 1 |
| Introduction | 2 |
| Purpose and Scope | 2 |
| Existing and Proposed Drainage Conditions | 2 |
| Storm Water Drainage Methodology | 4 |
| Hydrologic Analysis | 4 |
| Rain Fall Data | 4 |
| Watershed Description | 4 |
| Land Use | 6 |
| Soil Type | 7 |
| <i>Hydrologic Calculations</i> | 8 |
| Runoff Curve Number | 9 |
| Time of Concentration | 12 |
| Storm Drainage Plan | 19 |
| Storm Drainage Facility Plan | 19 |
| Appendices | 25 |
| Appendix A – Rain Fall Data | 26 |
| Appendix B – TR-55, Table 2-2 | 34 |

Purpose and Scope

As the growth in Utah continues, the need for large developments also increases. The growth in Utah County is no exception to this trend. The growth in Utah County increases on the east side of the valley, and possibly at a higher pace on the west side of the valley. Pole Canyon is a planned large community with many amenities. The different types of zoning that will exist will include residential, commercial, open space and some light industrial. The purpose of the Pole Canyon drainage study is to analyze the existing drainage conditions of the watershed and proposed development, then develop a drainage plan for the proposed development. The hydrologic analysis includes the entire watershed upstream of the proposed development, which includes Pole Canyon, and the entire proposed development. However, the analysis will separate the watershed upstream of the proposed development from the proposed development for planning purposes. Throughout this drainage report the watershed upstream of the proposed development will be referred to the Pole Canyon watershed, and the watershed of the proposed development will be referred to as the proposed development.

Existing and Proposed Drainage Conditions

The study area is located West of Eagle Mountain, Utah at the mouth of Pole Canyon, is shown in Figure 1. The Pole Canyon watershed is shown in blue and the proposed development area is highlighted in red. The existing conditions for the Pole Canyon watershed were analyzed, while the proposed conditions for the development were analyzed.

The proposed development is located to the south of Cedar Fort approximately 1 mile. The total area of the Pole Canyon watershed is approximately 6,900 acres. The existing conditions of the terrain is described as high desert foothills with sloping topography to the east with a moderate amount of Utah native vegetation. The area of the proposed development is approximately 2,600 acres and is proposed to have conditions that consist of numerous land use categories from low-density residential to light industrial. During a 100-year 24-hour storm event, the Pole Canyon watershed can produce a peak discharge up to approximately 466 cfs. In addition, 50-year 24-hour and 10-year 24-hour storm events can produce peak discharges of 258 cfs and 146 cfs, respectively.

Figure 1 – Pole Canyon Watershed

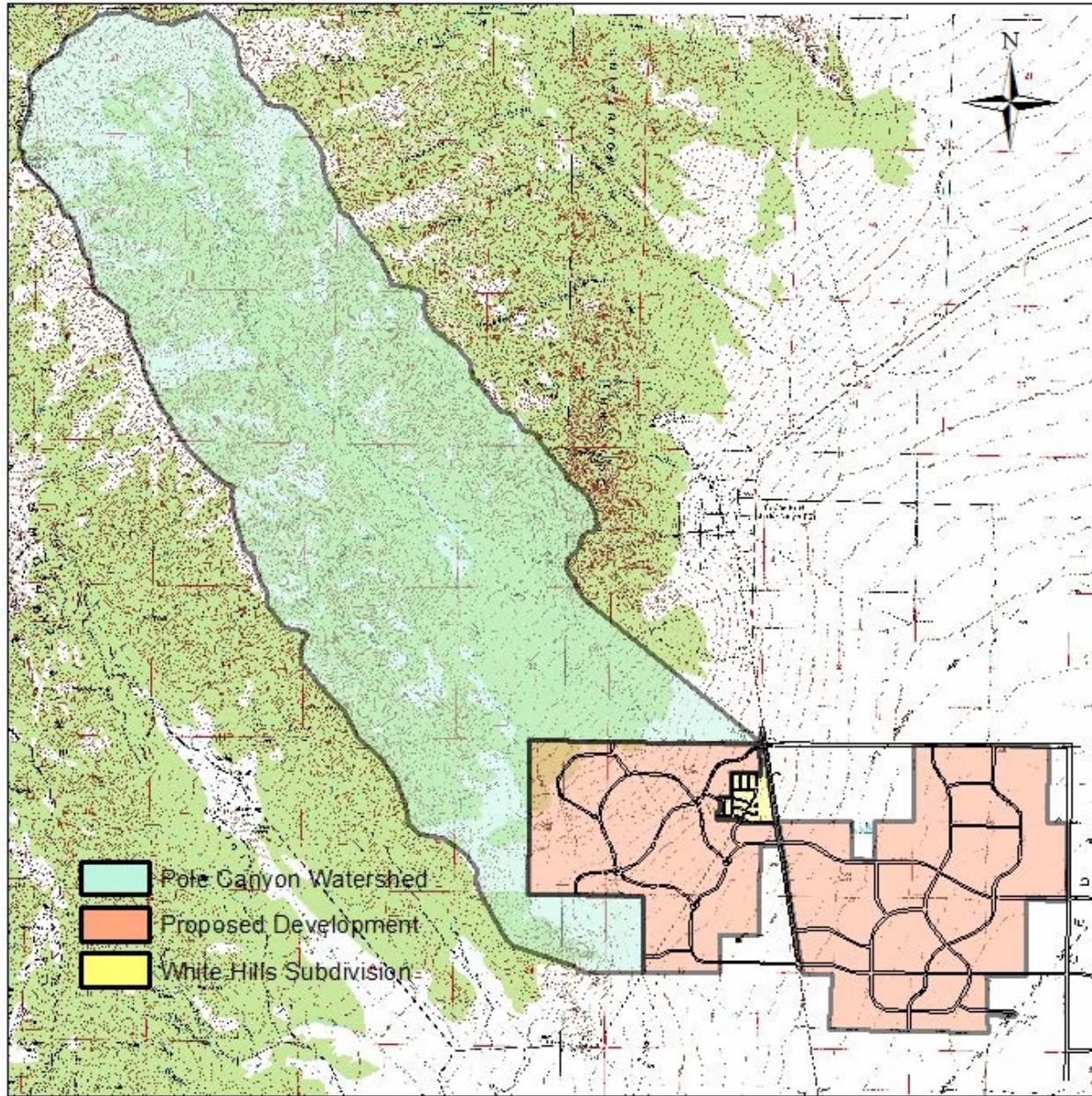

Storm Water Drainage Methodology

Hydrologic Analysis

The analysis of the existing and proposed storm drainage conditions is essential for the safety of everyday life and the prevention of loss of life in the proposed development of Pole Canyon. The existing and proposed conditions were analyzed using HEC-HMS, an Army Corps of Engineer's program. HEC-HMS was utilized to simulate storm rainfall events over the study areas. The storm events that were simulated were a 10-year 24-hour event and a 100-year 24-hour event. ESRI's ArcGIS was used to analyze land use, soil data, and basic geometry of the watershed.

Rain Fall Data

The rain fall data was obtained by using the National Weather Service website. This service provides local precipitation intensity and precipitation frequency estimates. The complete data obtained is shown in Appendix A. The data used for the 10-year 24-hour, 50-year 24-hour, and 100-year 24-hour events are shown in Table 1.

Table 1 – 10-year, 50-year, and 100-year Cumulative Rainfall Estimates

| Time (minutes) | 10-year (inches) | 50-year (inches) | 100-year (inches) |
|----------------|------------------|------------------|-------------------|
| 5 | 0.33 | 0.52 | 0.61 |
| 10 | 0.51 | 0.78 | 0.78 |
| 15 | 0.63 | 0.97 | 1.16 |
| 30 | 0.85 | 1.31 | 1.56 |
| 60 | 1.05 | 1.62 | 1.93 |
| 120 | 1.23 | 1.85 | 2.2 |
| 180 | 1.36 | 1.99 | 2.34 |
| 360 | 1.77 | 2.37 | 2.71 |
| 720 | 2.36 | 3.11 | 3.47 |
| 1440 | 3.15 | 4.10 | 4.53 |

The cumulative rain fall estimates were then interpolated to obtain fifteen (15) minute intervals for the full 24-hour storm events. The interpolation was calculated using a linear relationship with between the two given estimations. Both cumulative hydrographs along with the data are shown in Appendix A.

Watershed Description

There were two watershed areas analyzed. The first was the Pole Canyon watershed. The Pole Canyon watershed area is approximately 10.9 square miles. Within the 10.9 square miles, the slopes can vary from 1 to 35 percent; the and use differs from a cropland and pasture mixture to evergreen forest land; and the soils range from the Hydrologic Soil Groups B, C and D. The watershed area was divided into four different subbasins. These watershed subbasins or areas were named Basin A, B, C and D, as shown in Figure 2. Basin C was divided into four subbasins and Basin D was divided

into two subbasins to help simplify calculations and reduce any errors. The land characteristics of the watershed vary due to the fact of the size. The watershed has four different points of discharge into the proposed development. Each of these discharge points has an associated watershed area above it which is responsible for producing the existing drainage conditions. These discharge points are located and also shown in Figure 2. The area associated with each watershed is shown in Figure 2 and in Table 6.

Figure 2 – The Pole Canyon Watershed Area – Subbasins with Discharge Points

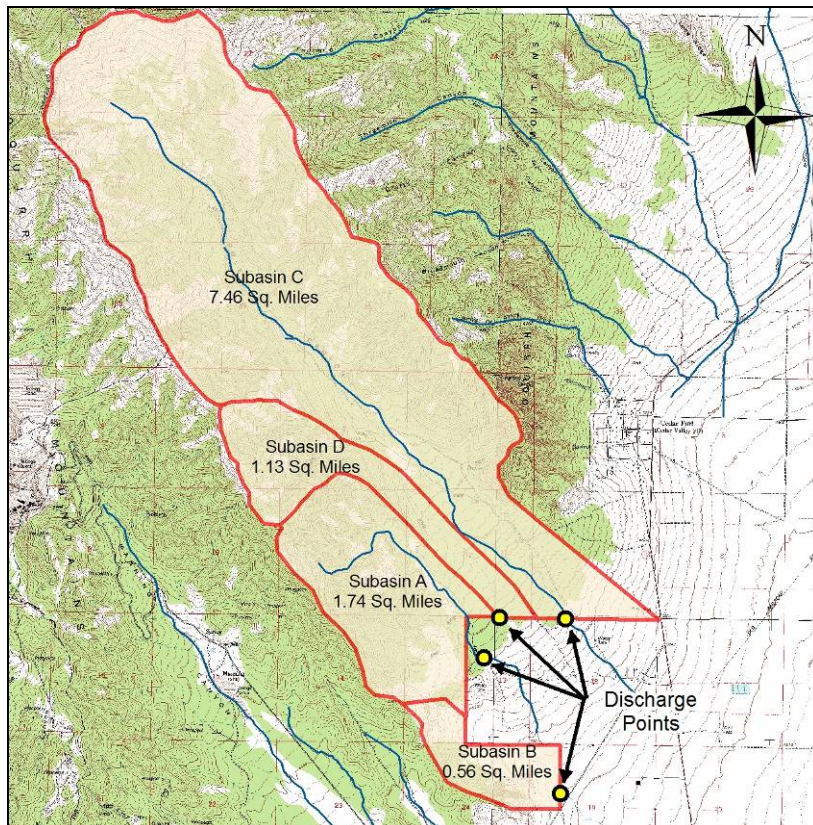

The second was the proposed development itself including White Hills Subdivision. The watershed area is approximately 4.3 square miles. Within the 4.3 square miles, the slopes can vary from 8 to 0.3 percent; the land use differs from a low density residential to light industrial; and the soils range from the Hydrologic Soil Groups B, C and D. The watershed area was divided into fourteen different subbasins of the proposed development and one for White Hills Subdivision (named Subbasin 0). These watershed subbasins or areas were named Subbasin 1 thru 14, as shown in Figure 3. The land characteristics of the watershed vary due to the fact of the size. The watershed has two different points of discharge out of the proposed development. Each of these discharge points has an associated watershed area above it which is responsible for producing the existing drainage conditions. These discharge points are located and also shown in Figure 3. The area associated with each watershed is shown in Figure 3 and in Table 6.

Figure 3 – The Watershed Area – Sub-areas with Discharge Points

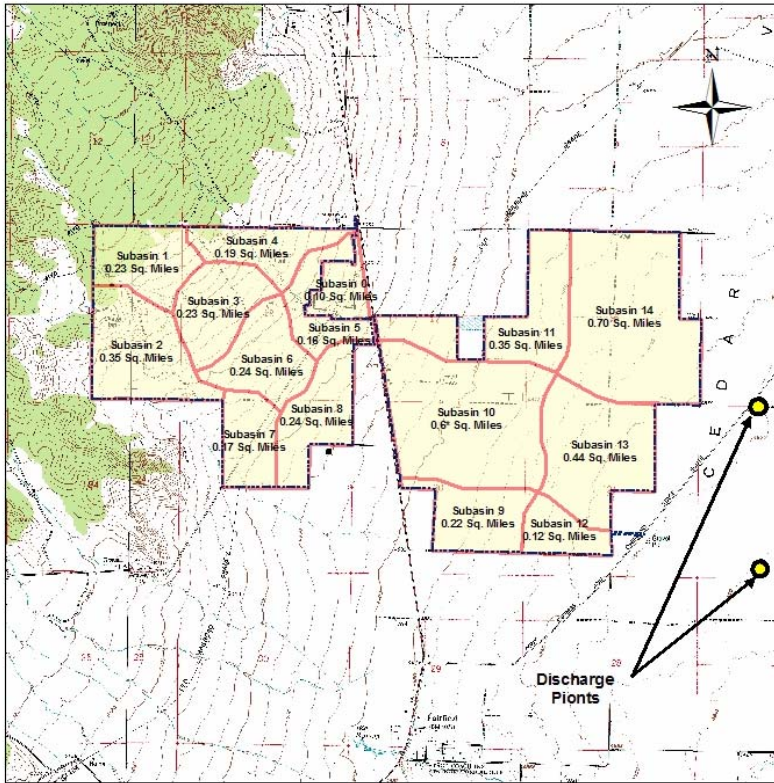

Land Use

As stated previously, the Pole Canyon watershed has many different land types. Figure 4 shows that the land use has five distinct types which include – Cropland and Pasture, Deciduous Forest Land, Evergreen Forest Land, Mixed Forest Land, and Shrub and Brush Rangeland. The Cropland and Pasture, Evergreen Forest Land and Mixed Forest Land land types are located near the southern end of the watershed or the lower elevations. While the Deciduous Forest Land land type is concentrated in the northern portion of the watershed and the Shrub and Brush Rangeland land type is dispersed throughout the watershed.

Figure 4 – Watershed Land Use Types

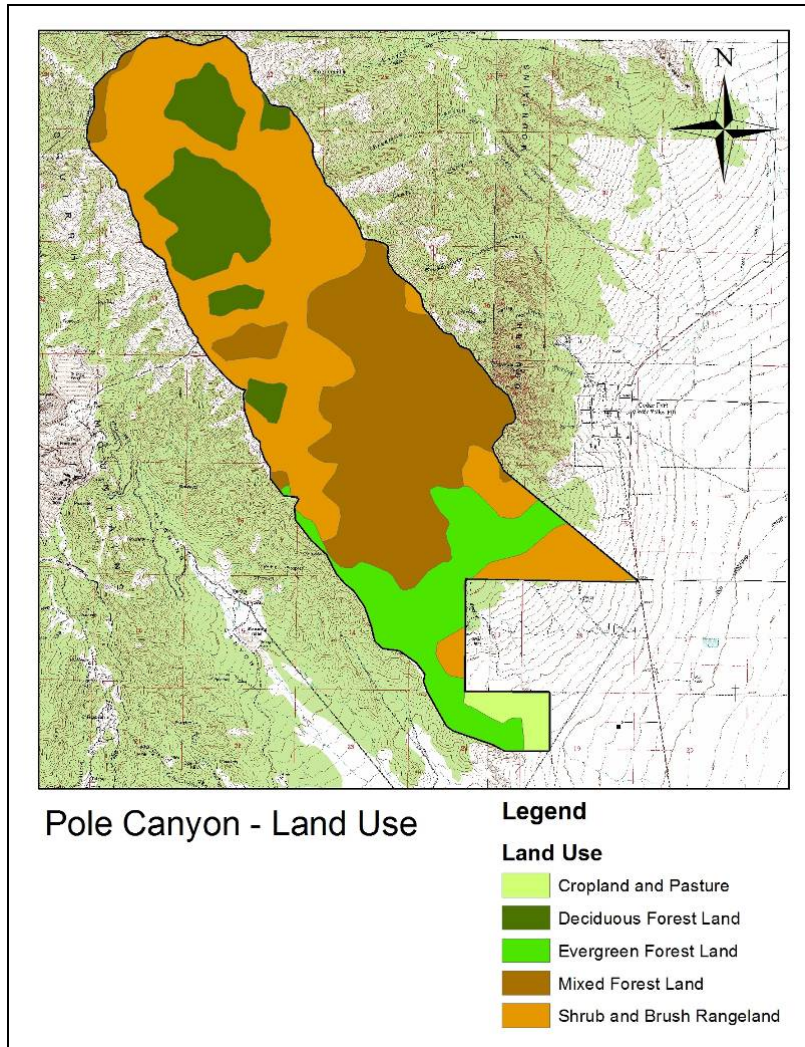

The proposed development will contain land use types Low- Density Residential, Medium-Density Residential, High-Density Residential Commercial, Light Industrial, and Open Space. For the purposes of estimating the necessary storm runoff and sizing infrastructure, an average lot size must be determined and assigned an appropriate irrigated acreage. This is determined by first calculating the average lot size for the development and then applying the correct usage requirement per State guidelines. In the case of Pole Canyon, the average gross density is 3.5 ERC per acre which corresponds most closely to $\frac{1}{5}$ acre lots after allowances for roads, sidewalk and infrastructure are made. This is the value that will be used in this drainage report for planning purposes.

Soil Type

Infiltration rates of soils vary widely and are affected by subsurface permeability as well as surface intake rates. Soils are classified into four Hydrologic Soil Group's (HSG), A, B, C and D, according to their minimum infiltration rate, which is obtained for bare soil

after prolonged wetting. The soils in the watershed of Pole Canyon are shown in Figure 5. The watershed contains soil from the HSG's B, C and D. Soil from Groups B and D are located throughout the watershed. While soil from Group C, are located predominately in the center of the watersheds. No soil from Group A was located within the watershed area.

Figure 5 – Watershed Hydrologic Soil Groups

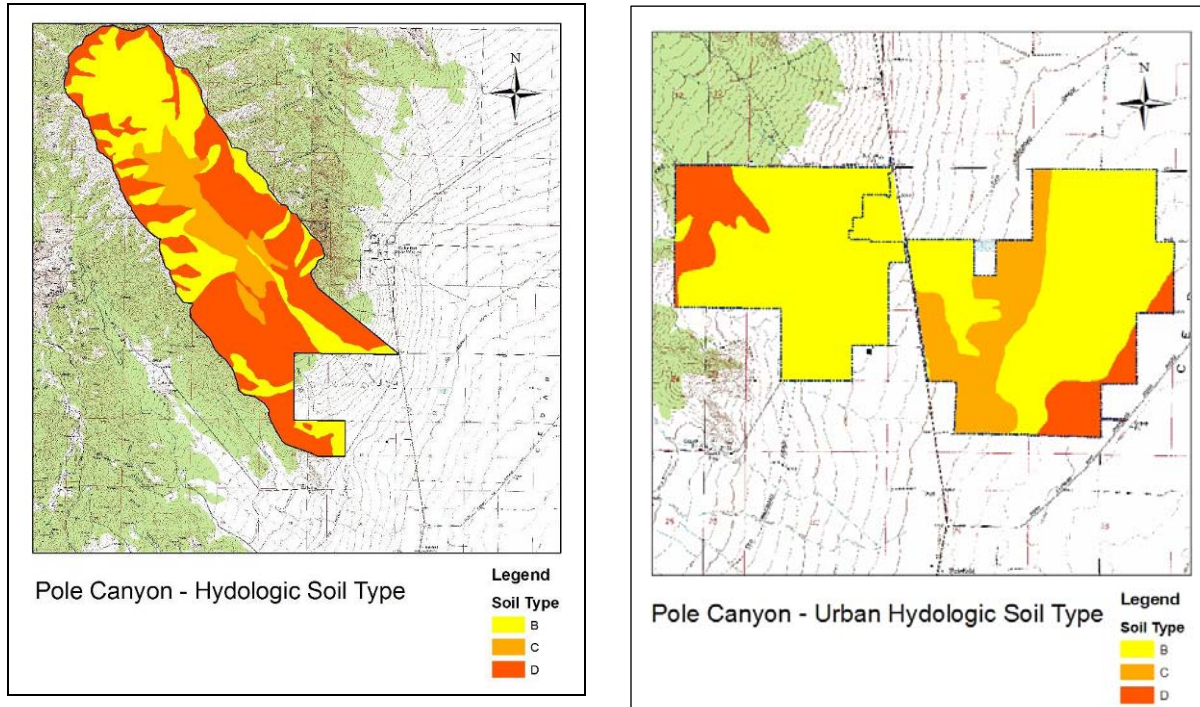

Hydrologic Calculations

To estimate the peak rate of discharge by the runoff from the storm rainfall, the Soil Conservation Service (SCS) and Technical Report 55 (TR-55) procedures were followed. Runoff is determined primarily by the amount of precipitation and by infiltration characteristics related to soil type, soil moisture, antecedent rainfall, cover type, impervious surfaces, and surface retention. Travel time is determined primary by slope, length of flow path, depth of flow, and roughness of flow surfaces. Peak discharges are based on the relationship of these parameters and on the total drainage area of the watershed and the time distribution of rainfall during a given storm event.

The TR-55 procedures begin with a rainfall amount uniformly imposed on the watershed over a specified time distribution. For this study, the rainfall data of 10-year 24-hour, 50-year 24-hour, and 100-year 24-hour storm events were used. The mass rainfall is converted to mass runoff by using a runoff curve number (CN). CN values are based on soils, plant cover, amount of impervious areas, interception and surface storage. The runoff is then transformed into a hydrograph by using unit hydrograph theory and routing procedures that depend on the runoff travel time through the different segments of the watershed. In this study, no surface storage is used. The rainfall data, CN

values, time of concentration values, and watershed area was entered into the HEC-HMS program and the hydrograph and runoff values were produced using the above description.

Runoff Curve Number

To obtain the CN values for this study, the soil and land use information was used. The land use and soil data was combined to determine the type of soil each land use type possessed. Figure 6 shows the combination of the hydrologic soil group with the land use types.

Figure 6 – Hydrologic Soil Groups combined with Land Use Types

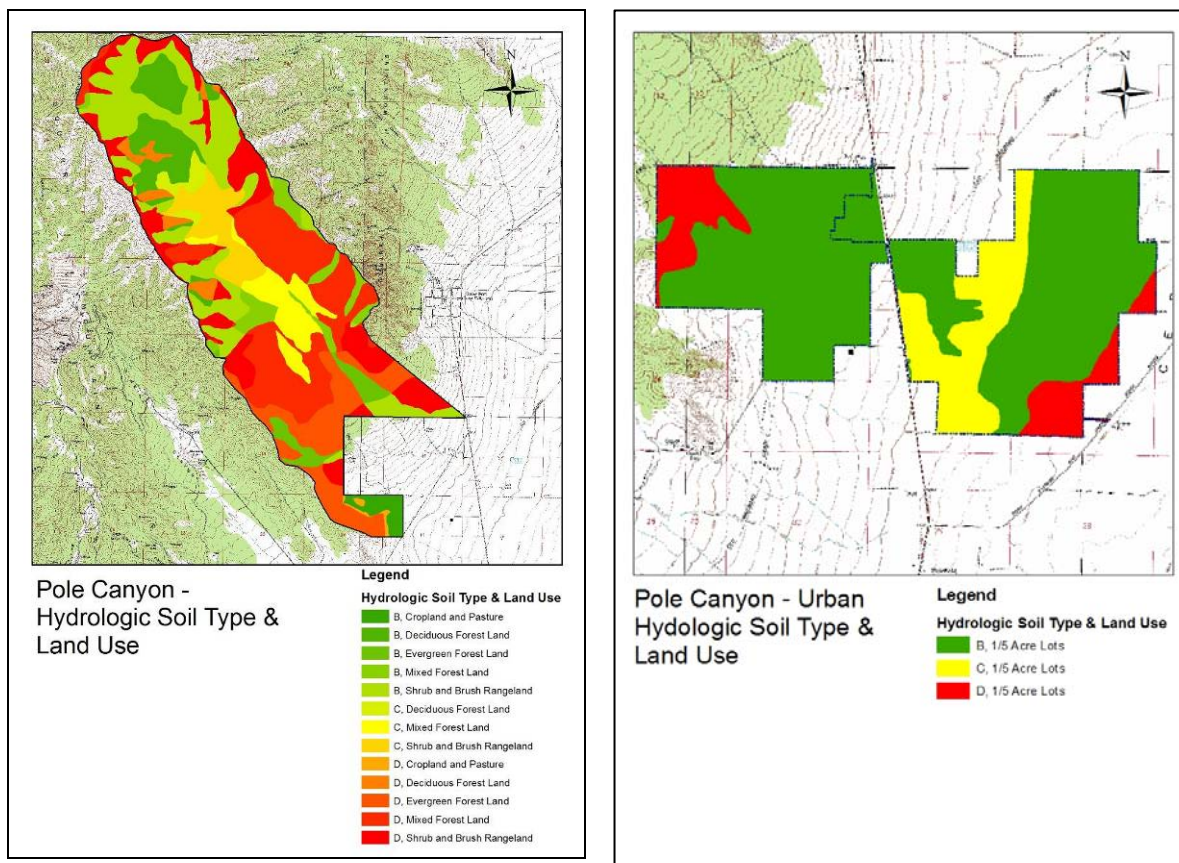

Using the Table 2-2 from TR-55, the CN values were selected. Table 2-2 from TR-55 is shown is Appendix C. To use Table 2-2, the land use types must be identified and then compared to Table 2-2, and then the HSG is selected. The CN values for this study were selected using a soil condition in between Fair and Poor. After the CN values were selected for each land use types and subbasin area, a weighted CN value was calculated based on land area percentage. The final CN values are shown in Table 2 and Table 3.

Table 2 – Calculated CN Values – Pole Canyon Watershed

| CN | Land Use Type | Hydrologic Soil Group | Total Area (AC) | Percent of Area in Subbasin | Area Percentage weighted CN Value |
|-------------------|---------------------------|------------------------------|------------------------|------------------------------------|------------------------------------------|
| Subbasin A | | | 1.74 | 100 | 68 |
| 55 | Evergreen Forest Land | B | 0.16 | 9 | 4.9 |
| 57 | Shrub and Brush Rangeland | B | 0.02 | 1 | 0.6 |
| 64 | Mixed Forest Land | C | 0.10 | 6 | 3.8 |
| 69 | Evergreen Forest Land | D | 0.54 | 31 | 21.5 |
| 69 | Mixed Forest Land | D | 0.74 | 42 | 29.3 |
| 76 | Shrub and Brush Rangeland | D | 0.18 | 10 | 7.9 |
| Subbasin B | | | 0.56 | 100 | 72 |
| 74 | Cropland and Pasture | B | 0.19 | 34 | 24.8 |
| 55 | Evergreen Forest Land | B | 0.00 | 0 | 0.0 |
| 86 | Cropland and Pasture | D | 0.04 | 7 | 5.9 |
| 69 | Evergreen Forest Land | D | 0.30 | 53 | 36.8 |
| 76 | Shrub and Brush Rangeland | D | 0.03 | 6 | 4.8 |
| Subbasin C | | | 7.45 | 100 | 64 |
| 74 | Cropland and Pasture | B | 0.00 | 0 | 0.0 |
| 55 | Deciduous Forest Land | B | 0.91 | 12 | 6.7 |
| 55 | Evergreen Forest Land | B | 0.09 | 1 | 0.6 |
| 55 | Mixed Forest Land | B | 0.35 | 5 | 2.5 |
| 57 | Shrub and Brush Rangeland | B | 1.83 | 25 | 14.0 |
| 64 | Deciduous Forest Land | C | 0.18 | 2 | 1.6 |
| 64 | Mixed Forest Land | C | 0.43 | 6 | 3.7 |
| 70 | Shrub and Brush Rangeland | C | 0.66 | 9 | 6.2 |
| 69 | Deciduous Forest Land | D | 0.20 | 3 | 1.9 |
| 69 | Evergreen Forest Land | D | 0.16 | 2 | 1.5 |
| 69 | Mixed Forest Land | D | 1.40 | 19 | 13.0 |
| 76 | Shrub and Brush Rangeland | D | 1.25 | 17 | 12.7 |
| Subbasin D | | | 1.13 | 100 | 63 |
| 55 | Deciduous Forest Land | B | 0.02 | 2 | 1.1 |
| 55 | Evergreen Forest Land | B | 0.06 | 6 | 3.0 |
| 55 | Mixed Forest Land | B | 0.17 | 15 | 8.1 |
| 57 | Shrub and Brush Rangeland | B | 0.32 | 28 | 16.0 |
| 64 | Mixed Forest Land | C | 0.13 | 12 | 7.6 |
| 70 | Shrub and Brush Rangeland | C | 0.00 | 0 | 0.0 |
| 69 | Deciduous Forest Land | D | 0.06 | 6 | 3.9 |
| 69 | Evergreen Forest Land | D | 0.13 | 12 | 8.0 |
| 69 | Mixed Forest Land | D | 0.10 | 9 | 6.1 |
| 76 | Shrub and Brush Rangeland | D | 0.13 | 12 | 8.8 |

Table 3 – Calculated CN Values – Proposed Development

| CN | Land Use Type | Hydrologic Soil Group | Total Area (AC) | Percent of Area in Subbasin | Area Percentage weighted CN Value |
|---------------------------------------------|---------------|-----------------------|-----------------|-----------------------------|-----------------------------------|
| Subbasin 0 (White Hills Subdivision) | | | 0.10 | 100 | 75 |
| 75 | 1/5 Acre Lot | B | 0.00 | 100 | 75.0 |
| 83 | 1/5 Acre Lot | C | 0.00 | 0 | 0.0 |
| 87 | 1/5 Acre Lot | D | 0.00 | 0 | 0.0 |
| Subbasin 1 | | | 0.23 | 100 | 88 |
| 75 | 1/5 Acre Lot | B | 0.05 | 21 | 17.7 |
| 83 | 1/5 Acre Lot | C | 0.18 | 79 | 69.9 |
| 87 | 1/5 Acre Lot | D | 0.00 | 0 | 0.0 |
| Subbasin 2 | | | 0.35 | 100 | 85 |
| 75 | 1/5 Acre Lot | B | 0.25 | 72 | 60.1 |
| 83 | 1/5 Acre Lot | C | 0.10 | 28 | 25.1 |
| 87 | 1/5 Acre Lot | D | 0.00 | 0 | 0.0 |
| Subbasin 3 | | | 0.23 | 100 | 84 |
| 75 | 1/5 Acre Lot | B | 0.21 | 93 | 77.6 |
| 83 | 1/5 Acre Lot | C | 0.02 | 7 | 6.5 |
| 87 | 1/5 Acre Lot | D | 0.00 | 0 | 0.0 |
| Subbasin 4 | | | 0.19 | 100 | 84 |
| 75 | 1/5 Acre Lot | B | 0.19 | 100 | 83.7 |
| 83 | 1/5 Acre Lot | C | 0.00 | 0 | 0.0 |
| 87 | 1/5 Acre Lot | D | 0.00 | 0 | 0.0 |
| Subbasin 5 | | | 0.16 | 100 | 84 |
| 75 | 1/5 Acre Lot | B | 0.16 | 100 | 83.7 |
| 83 | 1/5 Acre Lot | C | 0.00 | 0 | 0.0 |
| 87 | 1/5 Acre Lot | D | 0.00 | 0 | 0.0 |
| Subbasin 6 | | | 0.24 | 100 | 84 |
| 75 | 1/5 Acre Lot | B | 0.24 | 100 | 83.7 |
| 83 | 1/5 Acre Lot | C | 0.00 | 0 | 0.0 |
| 87 | 1/5 Acre Lot | D | 0.00 | 0 | 0.0 |
| Subbasin 7 | | | 0.17 | 100 | 84 |
| 75 | 1/5 Acre Lot | B | 0.17 | 100 | 83.7 |
| 83 | 1/5 Acre Lot | C | 0.00 | 0 | 0.0 |
| 87 | 1/5 Acre Lot | D | 0.00 | 0 | 0.0 |
| Subbasin 8 | | | 0.24 | 100 | 84 |
| 75 | 1/5 Acre Lot | B | 0.24 | 100 | 83.7 |
| 83 | 1/5 Acre Lot | C | 0.00 | 0 | 0.0 |
| 87 | 1/5 Acre Lot | D | 0.00 | 0 | 0.0 |
| Subbasin 9 | | | 0.22 | 100 | 87 |
| 75 | 1/5 Acre Lot | B | 0.06 | 27 | 22.6 |
| 83 | 1/5 Acre Lot | C | 0.16 | 73 | 64.7 |
| 87 | 1/5 Acre Lot | D | 0.00 | 0 | 0.0 |
| Subbasin 10 | | | 0.65 | 100 | 86 |
| 75 | 1/5 Acre Lot | B | 0.32 | 50 | 41.8 |
| 83 | 1/5 Acre Lot | C | 0.32 | 50 | 44.5 |
| 87 | 1/5 Acre Lot | D | 0.00 | 0 | 0.0 |
| Subbasin 11 | | | 0.35 | 100 | 86 |
| 75 | 1/5 Acre Lot | B | 0.20 | 56 | 46.9 |
| 83 | 1/5 Acre Lot | C | 0.15 | 44 | 39.1 |
| 87 | 1/5 Acre Lot | D | 0.00 | 0 | 0.0 |
| Subbasin 12 | | | 0.12 | 100 | 87 |
| 75 | 1/5 Acre Lot | B | 0.04 | 31 | 25.6 |
| 83 | 1/5 Acre Lot | C | 0.09 | 69 | 61.6 |
| 87 | 1/5 Acre Lot | D | 0.00 | 0 | 0.0 |
| Subbasin 13 | | | 0.44 | 100 | 85 |
| 75 | 1/5 Acre Lot | B | 0.32 | 72 | 60.5 |
| 83 | 1/5 Acre Lot | C | 0.12 | 28 | 24.6 |
| 87 | 1/5 Acre Lot | D | 0.00 | 0 | 0.0 |
| Subbasin 14 | | | 0.03 | 100 | 84 |
| 75 | 1/5 Acre Lot | B | 0.03 | 100 | 83.7 |
| 83 | 1/5 Acre Lot | C | 0.00 | 0 | 0.0 |
| 87 | 1/5 Acre Lot | D | 0.00 | 0 | 0.0 |

Time of Concentration

Two hydrologic methods were used to calculate the time of concentration (TOC) to the discharge point downstream for the Pole Canyon watershed. Both methods were then compared for accuracy. The TR-55 method “Urban Hydrology for Small Watersheds” and Federal Aviation Administration (FAA) equations for watershed calculations were both used. The two times of concentration are both compared in Table 4.

As shown in Table 4, both times of concentration varied greatly. The most conservative was used in the hydrologic model for the proposed development of Pole Canyon. The TR-55 calculations were used for the times of concentration calculations for both of the watersheds. As the runoff flows down the watershed there are three types of flows that affect the flow rates. They are sheet, shallow concentrated and open channel flows. The following method is used to carry out the TR-55 calculations.

Table 4 – Times of Concentration – FAA vs. TR-55

| Watershed SubAreas | Method | | Watershed Subbasins | Method |
|--------------------|------------------|--------------------|---------------------|--------------------|
| | FAA TOC (min) | TR-55 TOC (min) | | TR-55 TOC (min) |
| Subbasin C | | | Subbasin 0 | 9.0 |
| 1 | 191.3 | 46.1 | Subbasin 1 | 7.8 |
| 2 | 244.5 | 49.7 | Subbasin 2 | 7.4 |
| 3 | 240.9 | 47.6 | Subbasin 3 | 9.9 |
| 4 | 314.8 | 69.8 | Subbasin 4 | 11.3 |
| Subbasin D | | | Subbasin 5 | 11.9 |
| 5 | 279.4 | 41.0 | Subbasin 6 | 13.1 |
| 6 | 303.0 | 53.6 | Subbasin 7 | 18.0 |
| Subbasin A | 238.6 | 65.8 | Subbasin 8 | 16.4 |
| Subbasin B | 265.3 | 72.1 | Subbasin 9 | 41.5 |
| | | | Subbasin 10 | 26.8 |
| | | | Subbasin 11 | 21.4 |
| | | | Subbasin 12 | 82.4 |
| | | | Subbasin 13 | 84.4 |
| | | | Subbasin 14 | 103.9 |

The flow was divided into three segments: sheet (overland) flow, shallow concentrated flow, and open channel flow. The three segments were then added together (shown in Equation 1) for the time of concentration total.

$$t_{total} = t_{sheet} + t_{shallow} + t_{open} \quad \text{Equation 1}$$

where: t_{total} = total time of concentration (total travel time)
 t_{sheet} = travel time for sheet flow
 $t_{shallow}$ = travel time for shallow concentration flow
 t_{open} = travel time for open channel flow

The sheet flow is flow over plane surfaces. With sheet flow, the friction value (Manning's n) is an effective roughness coefficient that includes the effect of raindrop impact; drag over the plane surface; obstacles such as litter, crop ridges, and rocks; and erosion and transportation of sediment. The Manning's roughness coefficient values for sheet flow are shown in Table 5.

Table 5 – Manning's Coefficient for Overland Sheet Flow

| Manning's Roughness for overland sheet flow | |
|----------------------------------------------------|-------|
| Surface Description | n |
| Smooth asphalt | 0.011 |
| Smooth concrete | 0.012 |
| Ordinary concrete lining | 0.013 |
| Good wood | 0.014 |
| Brick with cement mortar | 0.014 |
| Vitrified clay | 0.015 |
| Cast iron | 0.015 |
| Corrugated metal pipe | 0.024 |
| Cement rubble surface | 0.024 |
| Fallow (no residue) | 0.050 |
| Cultivated soils | |
| Residue cover ≤ 20% | 0.060 |
| Residue cover > 20% | 0.170 |
| Range (natural) | 0.130 |
| Grass | |
| Short prairie grass | 0.150 |
| Dense grasses | 0.240 |
| Bermuda grass | 0.410 |
| Woods | |
| Light underbrush | 0.400 |
| Dense underbrush | 0.800 |

The calculation of sheet flow is shown in Equation 2.

$$t_{sheet} = \frac{0.007(nL)^{0.8}}{(P_2)^{0.5} s^{0.4}} \quad \text{Equation 2}$$

where: t_{sheet} = travel time of sheet flow (hr)
 n = Manning's roughness coefficient
 L = flow length (ft)
 P_2 = 2-year, 24-hour rainfall (in)
 s = slope of hydraulic grade line (land slope, ft/ft)

After a maximum of 300 feet, sheet flow usually becomes shallow concentrated flow. The average velocity for this flow can be determined from Figure 6.

Figure 6 – Average Velocity Estimation for Shallow Concentration Flow

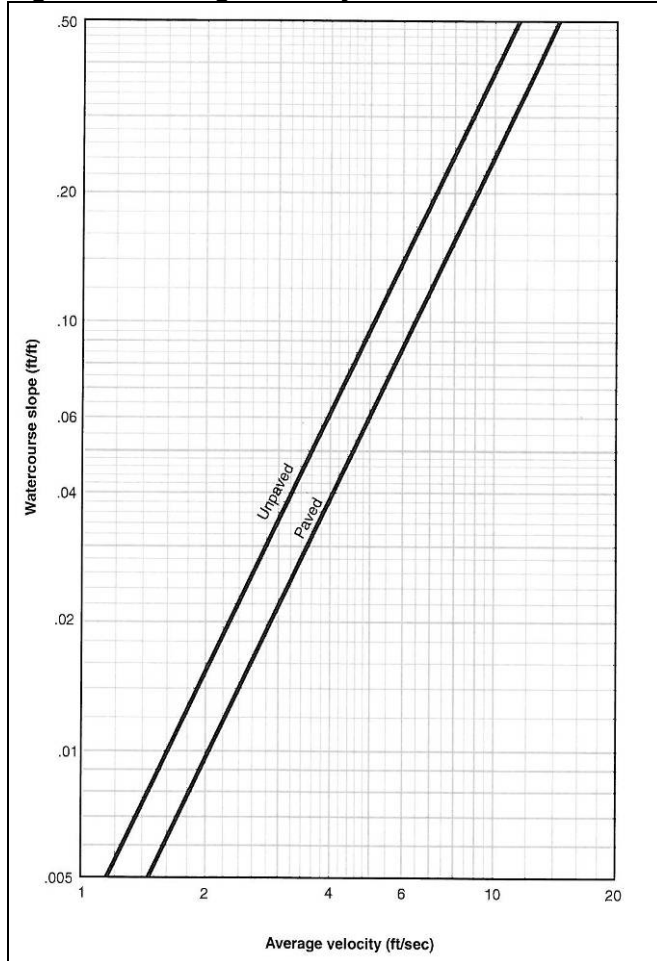

After determining the average velocity from Figure 6, Equation 3 is then used to determine the shallow concentration flow travel time.

$$t_{\text{shallow}} = \frac{L}{3600V} \quad \text{Equation 3}$$

where: t_{shallow} = travel time of shallow concentration flow (hr)
 L = flow length (ft)
 V = average velocity (ft/s)
 3600 = conversion factor from seconds to hours

The last portion of the time of concentration calculation is to determine the open channel flow travel time. Manning's equation or water surface profile information can be used to estimate average flow velocity.

The average velocity is determined by using Manning's equation shown in Equation 4.

$$V = \frac{1.49r^{\frac{2}{3}}s^{\frac{1}{2}}}{n} \quad \text{Equation 4}$$

where: V = average velocity (ft/s)
 r = hydraulic radius (ft) and is equal to a/p_w
 a = cross sectional flow area (ft²)
 p_w = wetter perimeter (ft)
 s = slope of the hydraulic grade line (channel slope, ft/ft)
 n = Manning's roughness coefficient for open channel flow (Table 4)

Table 6 – Manning's Coefficient for Channels and Pipes

| Values of Manning's coefficient for channels and pipes | |
|-----------------------------------------------------------------------|-------------|
| Conduit Material | n |
| <i>Closed conduits</i> | |
| Asbestos-cement pipe | 0.011-0.015 |
| Brick | 0.013-0.017 |
| Cast iron pipe | |
| Cement lined & seal coated | 0.011-0.015 |
| Concrete (monolithic) | 0.012-0.014 |
| Concrete pipe | 0.011-0.015 |
| Corrugated-metal pipe (0.5-2.5 inch corrugations) | |
| Plain | 0.022-0.026 |
| Paved invert | 0.018-0.022 |
| Spun asphalt lined | 0.011-0.015 |
| Plastic pipe (smooth) | 0.011-0.015 |
| Vitrified clay | |
| Pipes | 0.011-0.015 |
| Liner plates | 0.013-0.017 |
| <i>Open channels</i> | |
| Lined channels | |
| Asphalt | 0.013-0.017 |
| Brick | 0.012-0.018 |
| Concrete | 0.011-0.020 |
| Rubble or riprap | 0.020-0.035 |
| Vegetal | 0.030-0.040 |
| Excavated or dredged | |
| Earth, straight and uniform | 0.020-0.030 |
| Earth, winding, fairly uniform | 0.025-0.040 |
| Rock | 0.030-0.045 |
| Unmaintained | 0.050-0.140 |
| Natural channels (minor streams, top width at flood stage < 100 feet) | |
| Fairly regular section | 0.030-0.070 |
| Irregular section with pools | 0.040-0.100 |

After the average velocity is determined, Equation 3 is used to calculate the travel time for open channel flow. The total time of concentration can be determined by using

Equation 1. For the uncertainty of the time of concentrations, a conservative approach of using lag time was implemented. The lag time was calculated using Equation 5.

$$t_{lag} = 0.6 \times t_{total} \quad \text{Equation 5}$$

where: t_{lag} = lag time
 t_{total} = total time of concentration (min)

The calculated values for each basin in the Pole Canyon watershed are shown in Table 7. The calculated values for the subbasins of the proposed development are shown in Table 8.

Table 7 – Watershed Time of Concentration – Upstream of Proposed Development

| Section | Area (ac) | Area (mi) | t _{sheet} | t _{shallow} | t _{open channel} | t _{total} | t _{lag (min)} |
|----------------|-----------|-----------|--------------------|----------------------|---------------------------|--------------------|------------------------|
| Basin C | | | | | | | |
| 1 | 1011.7 | 1.6 | 23.34 | 4.76 | 17.97 | 46.1 | 27.6 |
| 2 | 1527.5 | 2.4 | 23.34 | 4.76 | 21.57 | 49.7 | 29.8 |
| 3 | 1293.0 | 2.0 | 23.34 | 4.76 | 19.53 | 47.6 | 28.6 |
| 4 | 904.4 | 1.4 | 23.34 | 6.06 | 40.40 | 69.8 | 41.9 |
| Basin D | | | | | | | |
| 5 | 434.3 | 0.7 | 23.34 | 4.76 | 12.90 | 41.0 | 24.6 |
| 6 | 271.7 | 0.4 | 23.34 | 6.06 | 24.16 | 53.6 | 32.1 |
| Basin A | 1109.7 | 1.7 | 25.52 | 4.76 | 35.48 | 65.8 | 39.5 |
| Basin B | 357.7 | 0.6 | 23.34 | 6.67 | 42.11 | 72.1 | 43.3 |

Table 8 – Watershed Time of Concentration – Proposed Development

| Section | Area (ac) | Area (mi) | t _{sheet} | t _{shallow} | t _{open channel} | t _{total} | t _{lag (min)} |
|-------------|-----------|-----------|--------------------|----------------------|---------------------------|--------------------|------------------------|
| Subbasin 0 | 64.0 | 0.10 | 2.99 | 5.2 | 0.82 | 9.0 | 6.0 |
| Subbasin 1 | 146.4 | 0.23 | 2.63 | 3.8 | 1.40 | 7.8 | 6.0 |
| Subbasin 2 | 221.1 | 0.35 | 2.49 | 3.3 | 1.66 | 7.4 | 6.0 |
| Subbasin 3 | 148.3 | 0.23 | 3.08 | 5.6 | 1.16 | 9.9 | 6.0 |
| Subbasin 4 | 121.1 | 0.19 | 3.03 | 5.4 | 2.81 | 11.3 | 6.8 |
| Subbasin 5 | 101.0 | 0.16 | 3.37 | 7.0 | 1.47 | 11.9 | 7.1 |
| Subbasin 6 | 153.0 | 0.24 | 3.54 | 7.9 | 1.65 | 13.1 | 7.9 |
| Subbasin 7 | 110.2 | 0.17 | 4.12 | 11.6 | 2.22 | 18.0 | 10.8 |
| Subbasin 8 | 155.7 | 0.24 | 4.01 | 10.9 | 1.50 | 16.4 | 9.8 |
| Subbasin 9 | 138.3 | 0.22 | 6.05 | 30.4 | 5.03 | 41.5 | 24.9 |
| Subbasin 10 | 432.6 | 0.68 | 4.62 | 15.5 | 6.68 | 26.8 | 16.1 |
| Subbasin 11 | 224.0 | 0.35 | 4.33 | 13.2 | 3.94 | 21.4 | 12.9 |
| Subbasin 12 | 79.3 | 0.12 | 8.47 | 70.4 | 3.52 | 82.4 | 49.4 |
| Subbasin 13 | 479.3 | 0.75 | 8.47 | 70.4 | 5.59 | 84.4 | 50.7 |
| Subbasin 14 | 444.9 | 0.70 | 9.05 | 83.2 | 11.71 | 103.9 | 62.4 |

After calculating the times of concentration, the lag time were entered into the HEC-HMS model. The peak discharge for the 10-year, 50-year, and 100-year storm events for the Pole Canyon watershed is shown in Table 9.

Table 9 – Subbasin Discharge Results Summary

| Peak Discharge | | | | |
|----------------|-------------------------------------|------------------------|------------------------|-------------------------|
| Basin | Drainage Area (mi ²) | 10-Year 24-Hr (cfs) | 50-Year 24-Hr (cfs) | 100-Year 24-Hr (cfs) |
| Basin A | 1.7 | 43.3 | 90.3 | 164.6 |
| Basin B | 0.6 | 18.4 | 45.0 | 74.3 |
| Basin C | 7.4 | 145.5 | 257.7 | 466.4 |
| 1 | 1.6 | 32.0 | 56.3 | 112.2 |
| 2 | 2.4 | 47.9 | 84.3 | 163.4 |
| 3 | 2.0 | 39.9 | 70.3 | 138.3 |
| 4 | 1.4 | 27.5 | 48.6 | 83.4 |
| Basin D | 1.1 | 20.5 | 36.8 | 66.1 |
| 5 | 0.7 | 13.2 | 23.6 | 44.9 |
| 6 | 0.4 | 7.4 | 13.4 | 22.8 |

As shown in Tables 9, the greatest amount of peak discharge occurs in Subbasin C. The amount of runoff calculated is approximately 146 cfs, 258 cfs, and 466 cfs for the 10-year, 50-year, and 100-year storm events, respectively.

The calculations of the times of concentration for the proposed development was computed and the lag times were entered into the HEC-HMS model. The peak discharge for the 10-year, 50-year and 100-year storm events for the proposed development is shown in Table 10 and the calculated allowable discharge rates are shown in Table 11. Although the subbasins have a computed peak discharge rate, the allowable discharge is regulated per storm event. This limited discharge rate is calculated in being the total peak discharge rate in cfs per acre of the total area within the subbasin. The regulated discharge rate is a commonly accepted practice by the surrounding communities.

Table 10 – Subbasin Discharge Results Summary

| Basin | Drainage Area (acres) | 10-yr Peak Discharge (cfs) | 50-yr Peak Discharge (cfs) | 100-yr Peak Discharge (cfs) |
|-----------------|-----------------------|----------------------------|----------------------------|-----------------------------|
| Subbasin-0 (WH) | 64.0 | 46.0 | 74.1 | 91.0 |
| Subbasin-1 | 147.2 | 42.4 | 104.2 | 143.7 |
| Subbasin-2 | 224.0 | 53.5 | 132.8 | 188.8 |
| Subbasin-3 | 147.2 | 28.7 | 72.5 | 106.4 |
| Subbasin-4 | 121.6 | 23.7 | 59.9 | 87.9 |
| Subbasin-5 | 102.4 | 20.0 | 50.4 | 74.0 |
| Subbasin-6 | 153.6 | 30.0 | 75.7 | 111.1 |
| Subbasin-7 | 108.8 | 19.1 | 51.1 | 75.8 |
| Subbasin-8 | 153.6 | 28.4 | 73.8 | 109.0 |
| Subbasin-9 | 140.8 | 24.7 | 61.4 | 87.7 |
| Subbasin-10 | 435.2 | 70.0 | 219.8 | 323.6 |
| Subbasin-11 | 224.0 | 43.0 | 123.1 | 178.5 |
| Subbasin-12 | 76.8 | 12.3 | 29.8 | 41.0 |
| Subbasin-13 | 480.0 | 59.9 | 154.1 | 218.6 |

Table 11 – Allowable Discharge Results Summary

| Basin | 10-year Release Rate (cfs/acre) | 50-year Release Rate (cfs/acre) | 100-year Release Rate (cfs/acre) |
|-------------------|----------------------------------------|----------------------------------------|-----------------------------------------|
| Subbasin 0 - (WH) | 0.31 | 0.50 | 0.62 |
| Subbasin 1 | 0.29 | 0.71 | 0.98 |
| Subbasin 2 | 0.36 | 0.90 | 1.28 |
| Subbasin 3 | 0.19 | 0.49 | 0.72 |
| Subbasin 4 | 0.16 | 0.41 | 0.60 |
| Subbasin 5 | 0.14 | 0.34 | 0.50 |
| Subbasin 6 | 0.20 | 0.51 | 0.75 |
| Subbasin 7 | 0.13 | 0.35 | 0.51 |
| Subbasin 8 | 0.19 | 0.50 | 0.74 |
| Subbasin 9 | 0.17 | 0.42 | 0.60 |
| Subbasin 10 | 0.48 | 1.49 | 2.20 |
| Subbasin 11 | 0.29 | 0.84 | 1.21 |
| Subbasin 12 | 0.08 | 0.20 | 0.28 |
| Subbasin 13 | 0.41 | 1.05 | 1.49 |

As shown in Tables 10 and 11, the greatest amount of peak discharge for all storm events occurs in Subbasin 10. The peak discharge calculated is approximately 70 cfs, 220 cfs, and 324 cfs for the 10-year, 50-year, and the 100-year storm events, respectively.

Storm Drainage Plan

Storm Drainage Facility Plan

During the event of a 100-year 24-hour storm, the proposed development could see an approximate peak discharge of 466 cfs from the Pole Canyon watershed. The proposed development can produce up to 70 cfs during a 10-year 24-hour storm event. According to surrounding communities practices, the 10-year 24-hour storm should be contained within the storm drain pipes, and the 100-year 24-hour storm event should be contained within the boundaries of the street right-of-way. This storm drainage plan has been created to be conservative to prevent the loss of life and property.

The proposed development is designed to convey the on-site drainage through a storm drainage collection system and have two drainage discharge locations. The discharge locations are shown in Figure 3 and Figure 7. The storm drainage collection system pipe sizing calculations are shown in Table 12. The calculations are separated into two sets, relating to the two different discharge points in existing storm drainage paths. Both sets show the flow origins and flow rates for the 10-year 24-minute storm event. The off-site drainage or the Pole Canyon watershed drainage is designed to be conveyed through the proposed development in a manner similar to the natural drainage.

Table 12 – Storm Drain Pipe Sizing

| Pipe Diameter (d) | | Depth of Flow (y) | | Cross-Sectional Area (A) | Percent Capacity | Slope (S) | Pipe Area | Flow Rate (Q) | | Velocity (V) | K Value | Flow Origin | Manning's Roughness Coefficient |
|-------------------|------|-------------------|---------|--------------------------|------------------|-----------|--------------------|---------------|--------|--------------|---------|-------------|---------------------------------|
| (in) | (ft) | (in) | (ft) | (ft ²) | | (ft/ft) | (ft ²) | (cfs) | (mgd) | (fps) | | (Basin) | (n) |
| 30 | 2.5 | 28 | 2.33333 | 4.77 | 97% | 0.049 | 4.91 | 97.92 | 63.31 | 20.5 | 1.49 | 1 | 0.013 |
| 30 | 2.5 | 28 | 2.33333 | 4.77 | 97% | 0.030 | 4.91 | 76.61 | 49.54 | 16.1 | 1.49 | + 2,3 | 0.013 |
| 36 | 3 | 34 | 2.83333 | 6.91 | 98% | 0.018 | 7.07 | 96.49 | 62.39 | 14.0 | 1.49 | + 6,7 | 0.013 |
| 48 | 4 | 45 | 3.75 | 12.24 | 97% | 0.010 | 12.57 | 154.93 | 100.17 | 12.7 | 1.49 | +8 | 0.013 |
| 60 | 5 | 56 | 4.66667 | 19.07 | 97% | 0.003 | 19.63 | 153.84 | 99.46 | 8.1 | 1.49 | +9,10 | 0.013 |
| 60 | 5 | 56 | 4.66667 | 19.07 | 97% | 0.002 | 19.63 | 125.61 | 81.21 | 6.6 | 1.49 | +12,13 | 0.013 |
| 24 | 2 | 22 | 1.83333 | 3.02 | 96% | 0.048 | 3.14 | 53.29 | 34.46 | 17.7 | 1.49 | 4 | 0.013 |
| 24 | 2 | 22 | 1.83333 | 3.02 | 96% | 0.010 | 3.14 | 24.32 | 15.73 | 8.1 | 1.49 | +5 | 0.013 |
| 36 | 3 | 34 | 2.83333 | 6.91 | 98% | 0.020 | 7.07 | 101.71 | 65.76 | 14.7 | 1.49 | +11 | 0.013 |
| 60 | 5 | 56 | 4.66667 | 19.07 | 97% | 0.003 | 19.63 | 153.84 | 99.46 | 8.1 | 1.49 | +14 | 0.013 |

The slope of the terrain is greater towards the west end of the proposed development. This is a slight problem with the storm drains. The slope impacts the capacity of the storm drain. The decrease in slope generally means the greater the size of the pipe. In this case, the plan for the storm drain is to remain the same size. That will mean that there is a possibility that the storm drain pipe will not have enough capacity to hold the 100-year storm event. In such an event, the storm drain pipe will over flow and spill over into the street. According to surrounding community practices, this practice is acceptable for the 100-year storm event. To prevent any damage to the street or any strong surge from storm spill over, bubble up man holes will be installed. Figure 7

shows the Pole Canyon proposed development and the location of the proposed storm drainage piping.

As stated, It is proposed that the Pole Canyon watershed drainage be conveyed through the proposed development in a manner and direction similar to its natural drainage. This is to be done with the use of manmade swales within the proposed pedestrian and equestrian trail easements. Proposed parks can be planned in a location such that the drainage can be collection and the park may be used as a retention / detention basin. This will allow the drainage to be detained and released at a more manageable rate. The courses or paths of the Pole Canyon watershed drainage run-on is shown in Figure 7. The volumes of storm run-off from the Pole Canyon watershed subbasins are estimated in Table 13. The subbasins are shown in Figure 2.

Table 13 – Estimated Storm Drainage Volumes from Pole Canyon

| 100-Year 24-Hr Storm Event | | | |
|----------------------------|----------------------------------|----------------------|------------------------|
| Basin | Drainage Area (mi ²) | Peak Discharge (cfs) | Estimated Volume (gal) |
| Basin A | 1.7 | 164.6 | 20,000,000 |
| Basin B | 0.6 | 74.3 | 10,000,000 |
| Basin C | 7.4 | 466.4 | 60,000,000 |
| Basin D | 1.1 | 66.1 | 10,000,000 |

The costs associated with the storm drainage plan are shown in Tables 14. Concrete head walls will also be installed at the point of concentration for erosion control and to help aid the flows into the storm drains.

Table 14 – Proposed Storm Drainage Plan Costs – Corrugated HDPE Pipe

| STORM DRAINAGE | | | | | |
|----------------|-----------------------------|----------|------|-----------------------------------|----------------------|
| Pole Canyon | | | | | |
| ITEM | DESCRIPTION | Quantity | Unit | Unit Cost | COST |
| 1 | Site Work (Swale) | 56,000 | LF | \$ 75 | \$ 4,200,000 |
| 2 | Corrugated Smooth Wall Pipe | | | | \$ - |
| | 24 inch | 23,400 | LF | \$ 50 | \$ 1,170,000 |
| | 30 inch | 6,500 | LF | \$ 55 | \$ 357,500 |
| | 36 inch | 24,700 | LF | \$ 60 | \$ 1,482,000 |
| | 48 inch | 4,300 | LF | \$ 90 | \$ 387,000 |
| | 60 inch | 8,000 | LF | \$ 175 | \$ 1,400,000 |
| 3 | Installation | 1 | lump | \$ - | \$ - |
| 4 | Storm Drainage Manhole | | | | |
| | 48-60 inch diameter | 165 | each | \$ 3,500 | \$ 577,500 |
| | 72 inch diameter | 6 | each | \$ 4,500 | \$ 27,000 |
| | 84 inch diameter | 5 | each | \$ 6,000 | \$ 30,000 |
| | | | | Subtotal | \$ 9,631,000 |
| | | | | Project Subtotal | \$ 9,631,000 |
| | | | | 20% Contingency | \$ 1,926,200 |
| | | | | Construction Cost Subtotal | \$ 11,557,200 |

As stated previously, Figure 7 shows the proposed storm drainage system to convey storm water run-off from the foothills and canyons west of the development. The intent of this storm drainage system is to pass only the off-site storm run-off through the development in the direction of the natural drainage in a manner that will protect proposed development. This infrastructure will be constructed on an as needed basis as development occurs. All upgrades are system upgrades and should be attributable to growth and thus impact fee eligible.

It is proposed that storm water generated by developments will be contained regionally within proposed parks and open space. These detention areas are also shown in Figure 7. Each subbasin will produce a certain volume that will be required to be detained in order to minimize the large volume from the run-off. These detention areas will be designed to detain the required amount from each subbasin. The amount of run-off from that will be required from each subbasin is shown in Table 15. The total area required in Table 15 takes into account that each detention area will have a minimum depth of 10 feet. In the event that development takes place downstream from a regional detention basin, infrastructure will be constructed in order to convey this storm water to the nearest detention area. The estimated costs for the detention areas are shown in Table 16.

Table 15 – Estimated Storm Drainage Detention Volumes and Areas Required

| Basin | Detention Volume (gal) | Detention Volume (ft ³) | Area Needed (ft ²) | Area Needed (acre) |
|-------------------|------------------------|-------------------------------------|--------------------------------|--------------------|
| Subbasin 0 - (WH) | 205,069 | 27,414 | 2,741 | 0.06 |
| Subbasin 1 | 459,667 | 61,449 | 6,145 | 0.14 |
| Subbasin 2 | 620,420 | 82,938 | 8,294 | 0.19 |
| Subbasin 3 | 359,739 | 48,090 | 4,809 | 0.11 |
| Subbasin 4 | 297,176 | 39,727 | 3,973 | 0.09 |
| Subbasin 5 | 250,253 | 33,454 | 3,345 | 0.08 |
| Subbasin 6 | 375,380 | 50,181 | 5,018 | 0.12 |
| Subbasin 7 | 265,894 | 35,545 | 3,554 | 0.08 |
| Subbasin 8 | 375,380 | 50,181 | 5,018 | 0.12 |
| Subbasin 9 | 412,918 | 55,199 | 5,520 | 0.13 |
| Subbasin 10 | 1,205,386 | 161,137 | 16,114 | 0.37 |
| Subbasin 11 | 620,420 | 82,938 | 8,294 | 0.19 |
| Subbasin 12 | 239,826 | 32,060 | 3,206 | 0.07 |
| Subbasin 13 | 1,316,436 | 175,982 | 17,598 | 0.40 |
| Subbasin 14 | 1,082,693 | 144,735 | 14,474 | 0.33 |

White Hills Subdivision currently has a storm drainage system. The system layout is shown in Figure 8. The existing storm drainage system consists of four catch basins and lines of 18 inch and 36 inch diameters. The storm water drains to the east of the subdivision in an existing natural drainage channel.

Table 16 – Proposed Storm Drainage Detention Areas Costs

| STORM DRAINAGE | | | | | |
|-----------------------------------|------------------------------|-----------------|-----------------|------------------|-------------------|
| Pole Canyon | | | | | |
| ITEM | DESCRIPTION | Quantity | Unit | Unit Cost | COST |
| 1 | Excavation | 41,000 | YD | \$ 8.00 | \$ 328,000 |
| 2 | Landscape and Irrigation | 110,000 | ft ² | \$ 1.00 | \$ 110,000 |
| 3 | Inlet / Outlet | 5 | lump | \$ 10,000 | \$ 50,000 |
| 4 | Emergency Overflow Structure | 5 | lump | \$ 5,000 | \$ 25,000 |
| Subtotal | | | | | \$ 513,000 |
| Project Subtotal | | | | | \$ 513,000 |
| 20% Contingency | | | | | \$ 102,600 |
| Construction Cost Subtotal | | | | | \$ 615,600 |

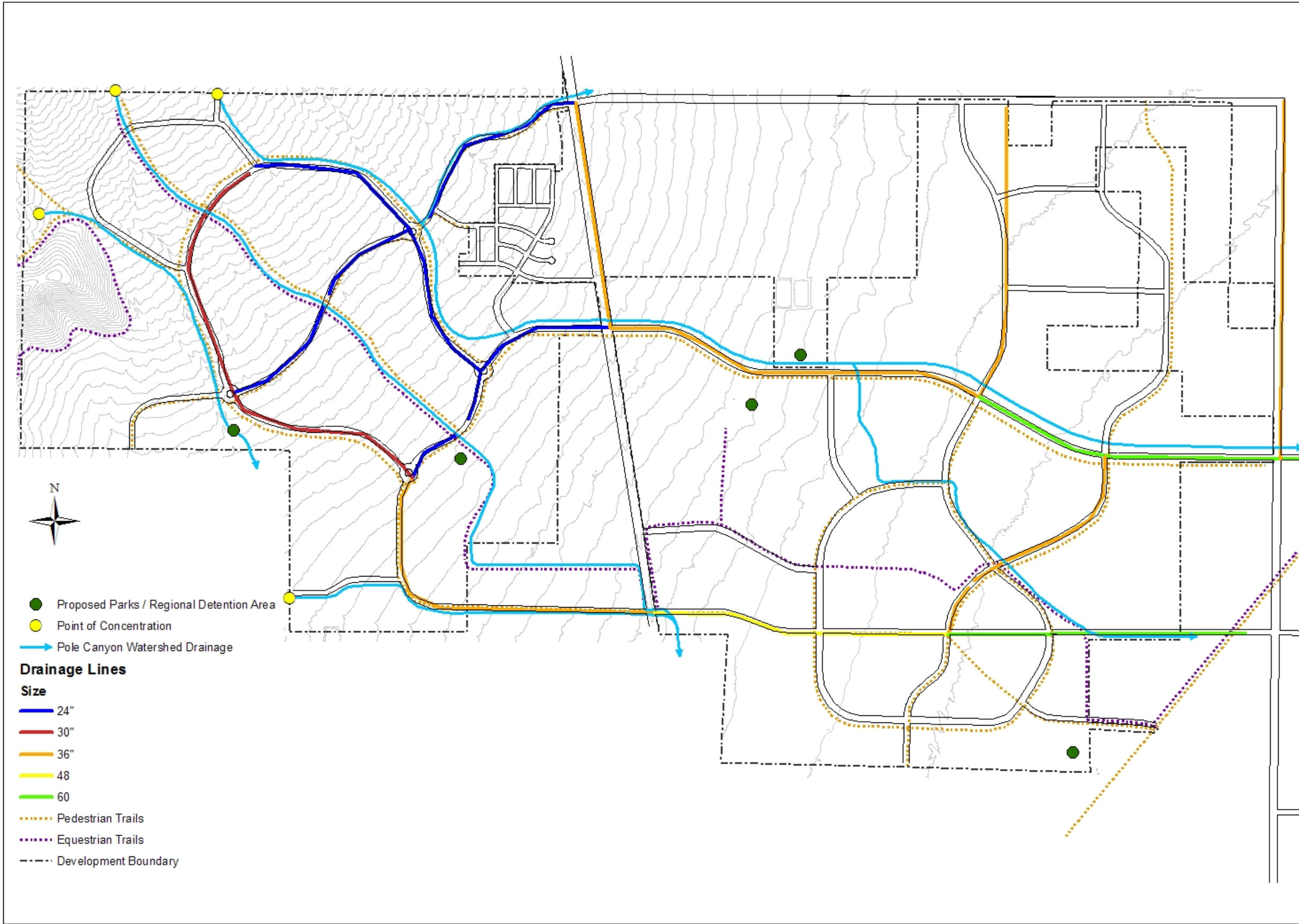

- Proposed Parks / Regional Detention Area
 - Point of Concentration
 - Pole Canyon Watershed Drainage
- Drainage Lines**
- Size**
- 24"
 - 30"
 - 36"
 - 48"
 - 60"
 - ⋯ Pedestrian Trails
 - ⋯ Equestrian Trails
 - - - Development Boundary

| ORIGINAL | | REVISIONS | |
|----------|------------|-------------|-----|
| NO. | DATE | DESCRIPTION | BY |
| 1 | 07/21/2008 | NEW | DM1 |
| 2 | 08/07/2008 | NEW | DM1 |

POLE CANYON DEVELOPMENT
 POLE CANYON STORM DRAINAGE MASTER PLAN
 STORM DRAINAGE ANALYSIS
 PROPOSED STORM DRAINAGE SYSTEM

AQUA
 ENGINEERING, INC.
 653 W. 2800 S., SUITE 275 BOUNTIFUL, UT 84070
 PHONE (801) 296-1327 FAX (801) 296-0153

FIGURE
7

WPM 08/28/2008 Pole Canyon Wet Utility Master Plan Storm Drainage White Hills Sub-division

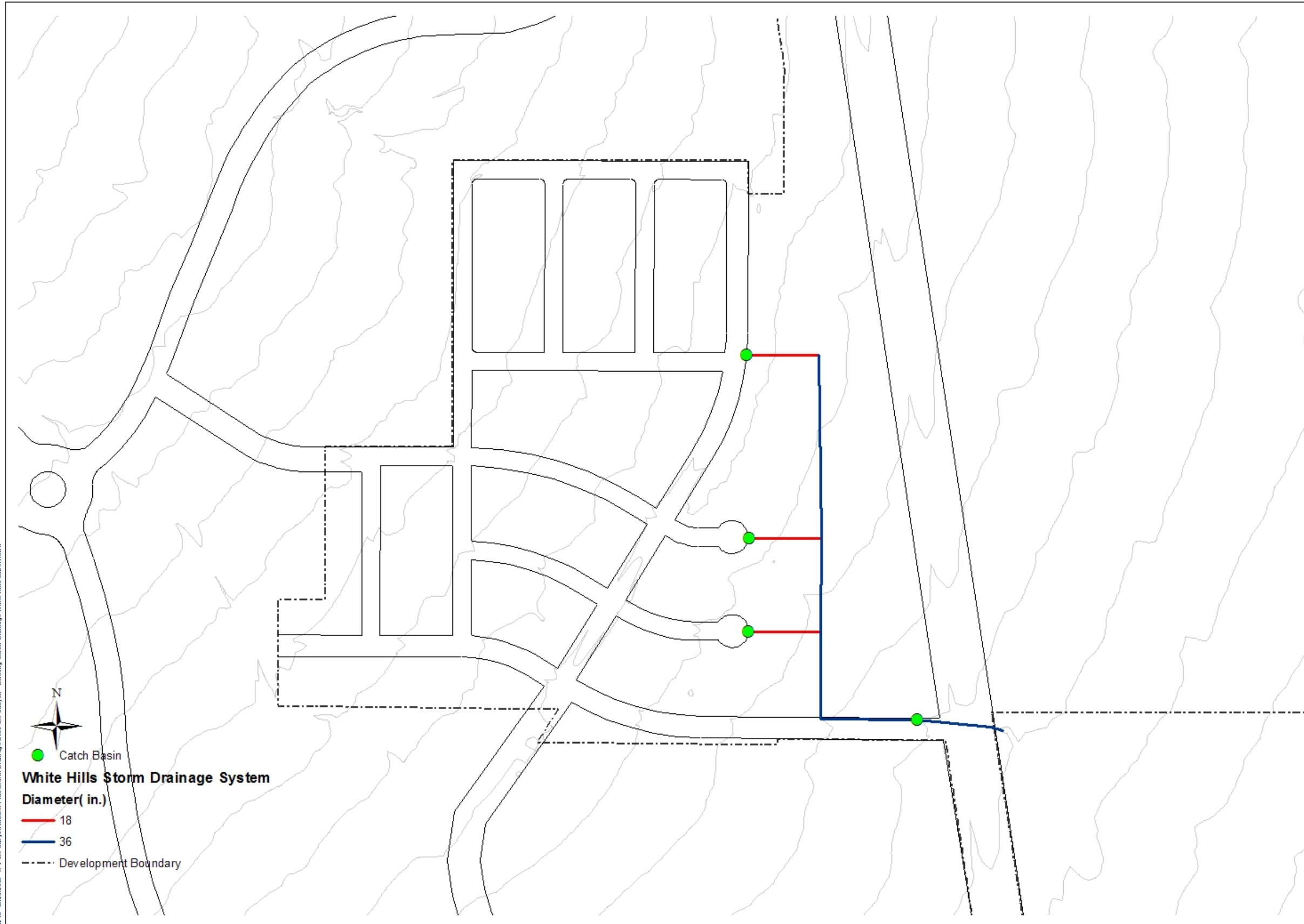

● Catch Basin
White Hills Storm Drainage System
Diameter (in.)
 — 18
 — 36
 - - - - Development Boundary

| ORIGINAL | | REVISIONS | |
|----------|------------|-------------|---------|
| NO. | DATE | DESCRIPTION | CHECKED |
| 1 | 08/21/2008 | MFM | DMH |
| 2 | 08/27/2008 | MFM | DMH |

POLE CANYON DEVELOPMENT
 POLE CANYON STORM DRAINAGE MASTER PLAN
 STORM DRAINAGE ANALYSIS
 WHITE HILLS EXISTING STORM DRAINAGE SYSTEM

AQUA
 ENGINEERING INC.
 653 W. 2500 S., SUITE 275 BOUNTIFUL, UT 84010
 PHONE (801) 296-1327 FAX (801) 296-0153

FIGURE
08

Appendices

Appendix A – Rain Fall Data

Appendix B – TR-55, Table 2-2

Appendix A – Rain Fall Data

Precipitation Frequency Data Server

<http://hdsc.nws.noaa.gov/cgi-bin/hdsc/builout.perl?type=pf&units=u...>



POINT PRECIPITATION FREQUENCY ESTIMATES FROM NOAA ATLAS 14



Utah 40.331 N 111.975 W 5347 feet

from "Precipitation-Frequency Atlas of the United States" NOAA Atlas 14, Volume 1, Version 4
G.M. Bonin, D. Martin, B. Liu, T. Parzybok, M. Yekta, and D. Riley
NOAA, National Weather Service, Silver Spring, Maryland, 2006

Extracted: Wed Jun 10 2009

[Confidence Limits](#) | [Seasonality](#) | [Location Maps](#) | [Other Info.](#) | [GIS data](#) | [Maps](#) | [Docs](#) | [Return to State Map](#)

Precipitation Frequency Estimates (inches)

| ARI* (years) | 5 min | 10 min | 15 min | 30 min | 60 min | 120 min | 3 hr | 6 hr | 12 hr | 24 hr | 48 hr | 4 day | 7 day | 10 day | 20 day | 30 day | 45 day | 60 day |
|-----------------|-------|--------|--------|--------|--------|---------|------|------|-------|-------|-------|-------|-------|--------|--------|--------|--------|--------|
| 1 | 0.11 | 0.17 | 0.22 | 0.29 | 0.36 | 0.44 | 0.49 | 0.62 | 0.76 | 0.87 | 0.99 | 1.14 | 1.34 | 1.49 | 1.93 | 2.28 | 2.79 | 3.25 |
| 2 | 0.14 | 0.22 | 0.27 | 0.37 | 0.46 | 0.56 | 0.61 | 0.77 | 0.93 | 1.06 | 1.21 | 1.39 | 1.63 | 1.81 | 2.35 | 2.77 | 3.39 | 3.94 |
| 5 | 0.20 | 0.31 | 0.38 | 0.51 | 0.64 | 0.73 | 0.79 | 0.94 | 1.13 | 1.27 | 1.43 | 1.64 | 1.93 | 2.12 | 2.76 | 3.25 | 3.94 | 4.57 |
| 10 | 0.25 | 0.39 | 0.48 | 0.64 | 0.80 | 0.89 | 0.94 | 1.10 | 1.29 | 1.43 | 1.60 | 1.85 | 2.16 | 2.37 | 3.07 | 3.61 | 4.36 | 5.05 |
| 25 | 0.33 | 0.51 | 0.63 | 0.85 | 1.05 | 1.15 | 1.18 | 1.33 | 1.53 | 1.65 | 1.84 | 2.14 | 2.47 | 2.69 | 3.46 | 4.07 | 4.87 | 5.64 |
| 50 | 0.41 | 0.62 | 0.77 | 1.04 | 1.28 | 1.39 | 1.40 | 1.52 | 1.71 | 1.82 | 2.02 | 2.36 | 2.70 | 2.92 | 3.73 | 4.40 | 5.21 | 6.03 |
| 100 | 0.49 | 0.75 | 0.93 | 1.26 | 1.55 | 1.67 | 1.68 | 1.75 | 1.91 | 1.99 | 2.19 | 2.59 | 2.92 | 3.13 | 3.98 | 4.71 | 5.51 | 6.39 |
| 200 | 0.59 | 0.91 | 1.12 | 1.51 | 1.87 | 1.99 | 2.01 | 2.03 | 2.16 | 2.18 | 2.37 | 2.81 | 3.13 | 3.34 | 4.20 | 5.00 | 5.76 | 6.68 |
| 500 | 0.75 | 1.15 | 1.42 | 1.92 | 2.37 | 2.50 | 2.52 | 2.55 | 2.56 | 2.59 | 2.61 | 3.11 | 3.40 | 3.58 | 4.46 | 5.34 | 6.00 | 6.99 |
| 1000 | 0.90 | 1.36 | 1.69 | 2.28 | 2.82 | 2.96 | 2.99 | 3.02 | 3.05 | 3.08 | 3.11 | 3.33 | 3.59 | 3.74 | 4.62 | 5.56 | 6.12 | 7.14 |

* These precipitation frequency estimates are based on a partial duration series. ARI is the Average Recurrence Interval.
Please refer to [NOAA Atlas 14 Document](#) for more information. NOTE: Formatting forces estimates near zero to appear as zero.

* Upper bound of the 90% confidence interval Precipitation Frequency Estimates (inches)

| ARI** (years) | 5 min | 10 min | 15 min | 30 min | 60 min | 120 min | 3 hr | 6 hr | 12 hr | 24 hr | 48 hr | 4 day | 7 day | 10 day | 20 day | 30 day | 45 day | 60 day |
|------------------|-------|--------|--------|--------|--------|---------|------|------|-------|-------|-------|-------|-------|--------|--------|--------|--------|--------|
| 1 | 0.14 | 0.21 | 0.26 | 0.34 | 0.42 | 0.51 | 0.56 | 0.69 | 0.83 | 0.93 | 1.06 | 1.24 | 1.45 | 1.60 | 2.07 | 2.44 | 2.98 | 3.45 |
| 2 | 0.17 | 0.26 | 0.32 | 0.44 | 0.54 | 0.64 | 0.69 | 0.84 | 1.02 | 1.14 | 1.29 | 1.50 | 1.77 | 1.95 | 2.53 | 2.97 | 3.62 | 4.20 |
| 5 | 0.24 | 0.36 | 0.45 | 0.61 | 0.75 | 0.84 | 0.89 | 1.04 | 1.24 | 1.36 | 1.52 | 1.77 | 2.07 | 2.27 | 2.96 | 3.47 | 4.19 | 4.84 |
| 10 | 0.30 | 0.46 | 0.57 | 0.76 | 0.94 | 1.03 | 1.06 | 1.21 | 1.42 | 1.53 | 1.71 | 1.99 | 2.31 | 2.53 | 3.29 | 3.84 | 4.62 | 5.33 |
| 25 | 0.40 | 0.60 | 0.75 | 1.01 | 1.25 | 1.33 | 1.34 | 1.47 | 1.68 | 1.76 | 1.95 | 2.29 | 2.63 | 2.87 | 3.69 | 4.33 | 5.14 | 5.93 |
| 50 | 0.49 | 0.74 | 0.92 | 1.24 | 1.54 | 1.61 | 1.63 | 1.69 | 1.90 | 1.94 | 2.14 | 2.53 | 2.88 | 3.11 | 3.98 | 4.68 | 5.49 | 6.34 |
| 100 | 0.60 | 0.91 | 1.12 | 1.51 | 1.88 | 1.96 | 1.98 | 2.00 | 2.14 | 2.16 | 2.33 | 2.78 | 3.11 | 3.34 | 4.24 | 5.01 | 5.79 | 6.70 |
| 200 | 0.73 | 1.11 | 1.37 | 1.85 | 2.29 | 2.37 | 2.40 | 2.42 | 2.45 | 2.48 | 2.52 | 3.02 | 3.35 | 3.56 | 4.49 | 5.32 | 6.05 | 7.01 |
| 500 | 0.94 | 1.43 | 1.77 | 2.39 | 2.96 | 3.05 | 3.08 | 3.11 | 3.14 | 3.17 | 3.20 | 3.35 | 3.64 | 3.83 | 4.76 | 5.69 | 6.29 | 7.31 |
| 1000 | 1.14 | 1.73 | 2.14 | 2.89 | 3.57 | 3.68 | 3.72 | 3.76 | 3.79 | 3.83 | 3.87 | 3.91 | 3.95 | 4.00 | 4.95 | 5.94 | 6.39 | 7.46 |

* The upper bound of the confidence interval at 90% confidence level is the value which 5% of the simulated quantile values for a given frequency are greater than.

** These precipitation frequency estimates are based on a partial duration series. ARI is the Average Recurrence Interval.
Please refer to [NOAA Atlas 14 Document](#) for more information. NOTE: Formatting prevents estimates near zero to appear as zero.

* Lower bound of the 90% confidence interval Precipitation Frequency Estimates (inches)

| ARI** (years) | 5 min | 10 min | 15 min | 30 min | 60 min | 120 min | 3 hr | 6 hr | 12 hr | 24 hr | 48 hr | 4 day | 7 day | 10 day | 20 day | 30 day | 45 day | 60 day |
|------------------|-------|--------|--------|--------|--------|---------|------|------|-------|-------|-------|-------|-------|--------|--------|--------|--------|--------|
|------------------|-------|--------|--------|--------|--------|---------|------|------|-------|-------|-------|-------|-------|--------|--------|--------|--------|--------|

| | | | | | | | | | | | | | | | | | | |
|------|------|------|------|------|------|------|------|------|------|------|------|------|------|------|------|------|------|------|
| 1 | 0.10 | 0.15 | 0.19 | 0.25 | 0.31 | 0.40 | 0.45 | 0.57 | 0.70 | 0.81 | 0.92 | 1.06 | 1.24 | 1.38 | 1.79 | 2.12 | 2.61 | 3.05 |
| 2 | 0.13 | 0.19 | 0.24 | 0.32 | 0.40 | 0.49 | 0.55 | 0.70 | 0.86 | 0.99 | 1.13 | 1.30 | 1.52 | 1.68 | 2.19 | 2.59 | 3.18 | 3.70 |
| 5 | 0.17 | 0.27 | 0.33 | 0.44 | 0.55 | 0.65 | 0.71 | 0.86 | 1.04 | 1.19 | 1.34 | 1.53 | 1.79 | 1.98 | 2.57 | 3.04 | 3.71 | 4.31 |
| 10 | 0.22 | 0.33 | 0.41 | 0.55 | 0.68 | 0.78 | 0.84 | 1.00 | 1.19 | 1.34 | 1.51 | 1.73 | 2.01 | 2.21 | 2.87 | 3.38 | 4.11 | 4.76 |
| 25 | 0.28 | 0.42 | 0.53 | 0.71 | 0.88 | 0.98 | 1.04 | 1.19 | 1.39 | 1.54 | 1.73 | 2.00 | 2.30 | 2.51 | 3.23 | 3.82 | 4.60 | 5.32 |
| 50 | 0.33 | 0.51 | 0.63 | 0.84 | 1.04 | 1.16 | 1.20 | 1.34 | 1.53 | 1.69 | 1.89 | 2.20 | 2.51 | 2.72 | 3.49 | 4.12 | 4.93 | 5.70 |
| 100 | 0.39 | 0.59 | 0.74 | 0.99 | 1.23 | 1.35 | 1.39 | 1.51 | 1.69 | 1.84 | 2.05 | 2.40 | 2.72 | 2.92 | 3.73 | 4.41 | 5.22 | 6.04 |
| 200 | 0.45 | 0.69 | 0.86 | 1.15 | 1.43 | 1.55 | 1.60 | 1.72 | 1.87 | 1.99 | 2.20 | 2.60 | 2.91 | 3.12 | 3.94 | 4.67 | 5.48 | 6.33 |
| 500 | 0.55 | 0.83 | 1.04 | 1.40 | 1.73 | 1.86 | 1.92 | 2.07 | 2.16 | 2.17 | 2.39 | 2.85 | 3.15 | 3.33 | 4.18 | 4.98 | 5.74 | 6.65 |
| 1000 | 0.63 | 0.95 | 1.18 | 1.59 | 1.97 | 2.12 | 2.18 | 2.36 | 2.39 | 2.42 | 2.53 | 3.04 | 3.32 | 3.48 | 4.34 | 5.19 | 5.88 | 6.82 |

* The lower bound of the confidence interval at 90% confidence level is the value which 5% of the simulated quantile values for a given frequency are less than.
 ** These precipitation frequency estimates are based on a partial duration maxima series. ARI is the Average Recurrence Interval.
 Please refer to NOAA Atlas 14 Document for more information. NOTE: Formatting prevents estimates near zero to appear as zero.

Text version of tables

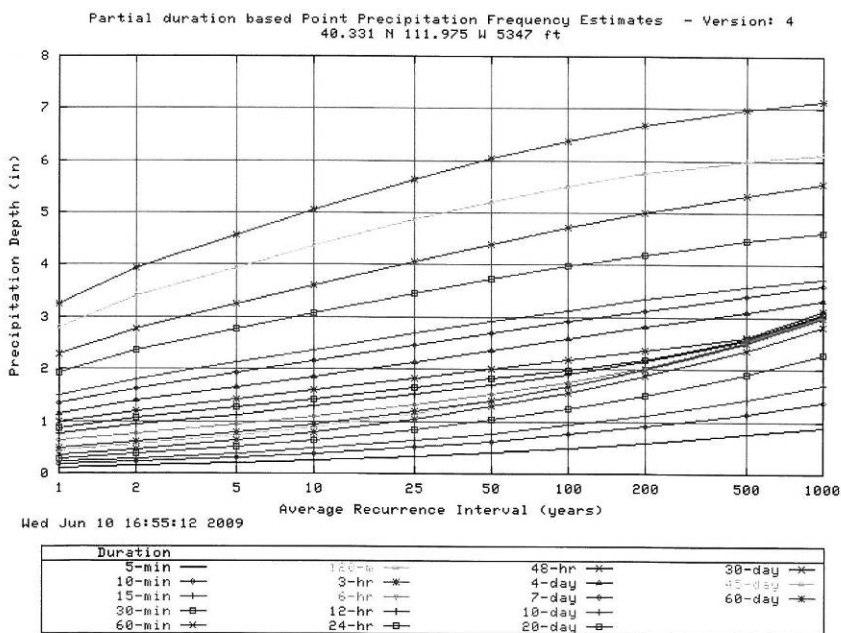

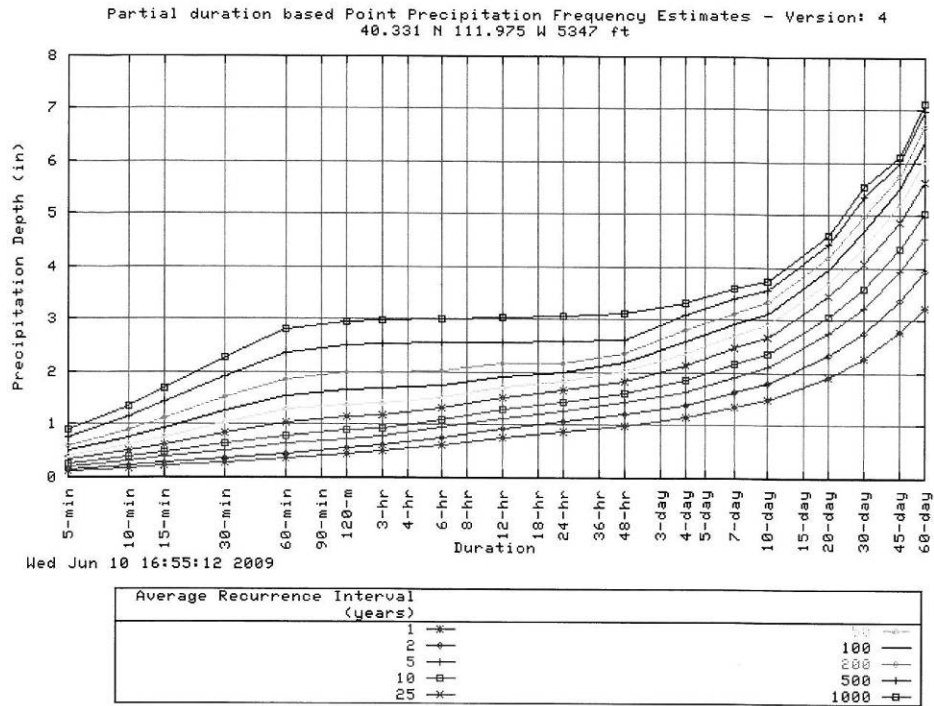

Maps -

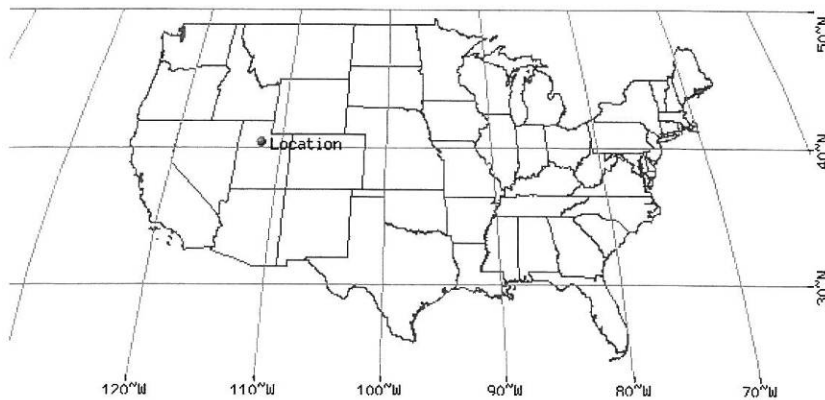

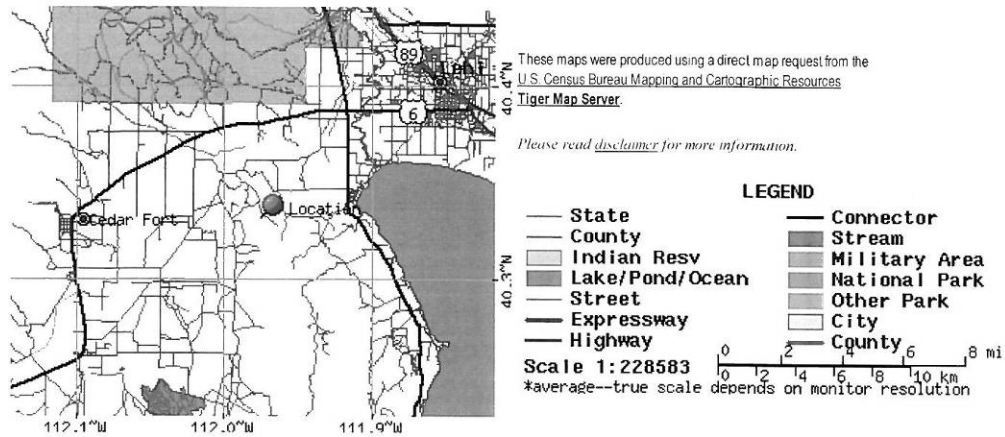

Other Maps/Photographs -

[View USGS digital orthophoto quadrangle \(DOQ\)](#) covering this location from TerraServer; [USGS Aerial Photograph](#) may also be available from this site. A DOQ is a computer-generated image of an aerial photograph in which image displacement caused by terrain relief and camera tilts has been removed. It combines the image characteristics of a photograph with the geometric qualities of a map. Visit the [USGS](#) for more information.

Watershed/Stream Flow Information -

[Find the Watershed](#) for this location using the U.S. Environmental Protection Agency's site.

Climate Data Sources -

Precipitation frequency results are based on data from a variety of sources, but largely NCDC. The following links provide general information about observing sites in the area, regardless of if their data was used in this study. For detailed information about the stations used in this study, please refer to [NOAA Atlas 14 Document](#).

Using the [National Climatic Data Center's \(NCDC\)](#) station search engine, locate other climate stations within: [+/-30 minutes](#) ...OR... [+/-1 degree](#) of this location (40.331/-111.975). Digital ASCII data can be obtained directly from [NCDC](#).

Find [Natural Resources Conservation Service \(NRCS\) SNOTEL \(SNOWpack TELemetry\)](#) stations by visiting the [Western Regional Climate Center's state-specific SNOTEL station maps](#).

Hydrometeorological Design Studies Center
 DOC/NOAA/National Weather Service
 1325 East-West Highway
 Silver Spring, MD 20910
 (301) 713-1669
 Questions?: HDSC_QUESTIONS@noaa.gov

[Disclaimer](#)



**POINT PRECIPITATION
FREQUENCY ESTIMATES
FROM NOAA ATLAS 14**



Utah 40.3655 N 112.1803 W 9120 feet

from "Precipitation-Frequency Atlas of the United States" NOAA Atlas 14, Volume I, Version 4
G.M. Bonnin, D. Martin, B.L.M. T. Parzybok, M. Yekta, and D. Riley
NOAA, National Weather Service, Silver Spring, Maryland, 2006
Extracted Thu Jun 11 2009

[Confidence Limits](#) | [Seasonality](#) | [Location Maps](#) | [Other Info.](#) | [GIS data](#) | [Maps](#) | [Docs](#) | [Return to State Ma](#)

| Precipitation Frequency Estimates (inches) | | | | | | | | | | | | | | | | | | |
|--------------------------------------------|----------|-----------|-----------|-----------|-----------|------------|---------|---------|----------|----------|----------|----------|----------|-----------|-----------|-----------|-----------|-----------|
| ARI* (years) | 5 min | 10 min | 15 min | 30 min | 60 min | 120 min | 3 hr | 6 hr | 12 hr | 24 hr | 48 hr | 4 day | 7 day | 10 day | 20 day | 30 day | 45 day | 60 day |
| 1 | 0.15 | 0.24 | 0.29 | 0.39 | 0.49 | 0.62 | 0.74 | 1.04 | 1.40 | 1.84 | 2.23 | 2.76 | 3.44 | 4.01 | 5.53 | 6.96 | 8.95 | 10.99 |
| 2 | 0.20 | 0.30 | 0.37 | 0.50 | 0.62 | 0.78 | 0.92 | 1.28 | 1.72 | 2.28 | 2.75 | 3.44 | 4.29 | 4.98 | 6.87 | 8.64 | 11.07 | 13.64 |
| 5 | 0.27 | 0.41 | 0.51 | 0.69 | 0.85 | 1.01 | 1.15 | 1.54 | 2.06 | 2.75 | 3.38 | 4.28 | 5.34 | 6.12 | 8.31 | 10.48 | 13.32 | 16.38 |
| 10 | 0.33 | 0.51 | 0.63 | 0.85 | 1.05 | 1.23 | 1.36 | 1.77 | 2.36 | 3.15 | 3.91 | 5.00 | 6.22 | 7.06 | 9.46 | 11.97 | 15.13 | 18.51 |
| 25 | 0.43 | 0.65 | 0.81 | 1.09 | 1.35 | 1.56 | 1.70 | 2.10 | 2.78 | 3.68 | 4.65 | 6.02 | 7.46 | 8.36 | 10.97 | 13.98 | 17.59 | 21.29 |
| 50 | 0.52 | 0.78 | 0.97 | 1.31 | 1.62 | 1.85 | 1.99 | 2.37 | 3.11 | 4.10 | 5.25 | 6.86 | 8.47 | 9.38 | 12.13 | 15.54 | 19.50 | 23.40 |
| 100 | 0.61 | 0.93 | 1.16 | 1.56 | 1.93 | 2.20 | 2.34 | 2.71 | 3.47 | 4.53 | 5.88 | 7.75 | 9.54 | 10.45 | 13.31 | 17.15 | 21.48 | 25.55 |
| 200 | 0.73 | 1.11 | 1.38 | 1.85 | 2.29 | 2.60 | 2.75 | 3.11 | 3.91 | 4.97 | 6.55 | 8.69 | 10.66 | 11.56 | 14.50 | 18.77 | 23.52 | 27.72 |
| 500 | 0.91 | 1.39 | 1.72 | 2.32 | 2.87 | 3.23 | 3.40 | 3.77 | 4.61 | 5.55 | 7.47 | 10.03 | 12.25 | 13.09 | 16.09 | 20.98 | 26.34 | 30.66 |
| 1000 | 1.08 | 1.65 | 2.04 | 2.75 | 3.41 | 3.81 | 3.99 | 4.36 | 5.16 | 6.01 | 8.22 | 11.12 | 13.54 | 14.32 | 17.34 | 22.69 | 28.63 | 32.98 |

* These precipitation frequency estimates are based on a partial duration series. ARI is the Average Recurrence Interval.
Please refer to [NOAA Atlas 14 Document](#) for more information. NOTE: Formatting forces estimates near zero to appear as zero.

| * Upper bound of the 90% confidence interval Precipitation Frequency Estimates (inches) | | | | | | | | | | | | | | | | | | |
|--------------------------------------------------------------------------------------------|----------|-----------|-----------|-----------|-----------|------------|---------|---------|----------|----------|----------|----------|----------|-----------|-----------|-----------|-----------|-----------|
| ARI** (years) | 5 min | 10 min | 15 min | 30 min | 60 min | 120 min | 3 hr | 6 hr | 12 hr | 24 hr | 48 hr | 4 day | 7 day | 10 day | 20 day | 30 day | 45 day | 60 day |
| 1 | 0.18 | 0.28 | 0.34 | 0.46 | 0.57 | 0.70 | 0.82 | 1.13 | 1.53 | 2.02 | 2.47 | 3.12 | 3.90 | 4.46 | 6.07 | 7.58 | 9.73 | 11.93 |
| 2 | 0.23 | 0.35 | 0.43 | 0.59 | 0.72 | 0.88 | 1.02 | 1.39 | 1.88 | 2.50 | 3.06 | 3.88 | 4.86 | 5.54 | 7.54 | 9.42 | 12.06 | 14.82 |
| 5 | 0.32 | 0.48 | 0.59 | 0.80 | 0.99 | 1.15 | 1.28 | 1.67 | 2.25 | 3.02 | 3.75 | 4.83 | 6.07 | 6.83 | 9.15 | 11.46 | 14.56 | 17.85 |
| 10 | 0.39 | 0.59 | 0.74 | 0.99 | 1.23 | 1.39 | 1.52 | 1.93 | 2.59 | 3.45 | 4.33 | 5.65 | 7.07 | 7.89 | 10.42 | 13.10 | 16.58 | 20.21 |
| 25 | 0.50 | 0.77 | 0.95 | 1.28 | 1.58 | 1.78 | 1.90 | 2.30 | 3.06 | 4.05 | 5.16 | 6.81 | 8.49 | 9.34 | 12.11 | 15.34 | 19.34 | 23.32 |
| 50 | 0.61 | 0.93 | 1.15 | 1.55 | 1.92 | 2.13 | 2.25 | 2.61 | 3.46 | 4.50 | 5.83 | 7.75 | 9.64 | 10.50 | 13.40 | 17.08 | 21.49 | 25.68 |
| 100 | 0.73 | 1.12 | 1.38 | 1.86 | 2.31 | 2.56 | 2.67 | 3.01 | 3.89 | 4.98 | 6.54 | 8.76 | 10.86 | 11.71 | 14.73 | 18.88 | 23.71 | 28.11 |
| 200 | 0.89 | 1.35 | 1.67 | 2.25 | 2.79 | 3.08 | 3.17 | 3.50 | 4.44 | 5.46 | 7.30 | 9.84 | 12.14 | 12.97 | 16.09 | 20.73 | 26.05 | 30.59 |
| 500 | 1.14 | 1.73 | 2.14 | 2.88 | 3.57 | 3.91 | 4.02 | 4.33 | 5.32 | 6.12 | 8.37 | 11.39 | 14.01 | 14.74 | 17.93 | 23.26 | 29.34 | 33.98 |
| 1000 | 1.38 | 2.10 | 2.60 | 3.50 | 4.33 | 4.72 | 4.83 | 5.09 | 6.04 | 6.65 | 9.26 | 12.68 | 15.54 | 16.18 | 19.39 | 25.26 | 32.05 | 36.71 |

* The upper bound of the confidence interval at 90% confidence level is the value which 5% of the simulated quantile values for a given frequency are greater than.
** These precipitation frequency estimates are based on a partial duration series. ARI is the Average Recurrence Interval.
Please refer to [NOAA Atlas 14 Document](#) for more information. NOTE: Formatting prevents estimates near zero to appear as zero.

| * Lower bound of the 90% confidence interval Precipitation Frequency Estimates (inches) | | | | | | | | | | | | | | | | | | |
|--------------------------------------------------------------------------------------------|----------|-----------|-----------|-----------|-----------|------------|---------|---------|----------|----------|----------|----------|----------|-----------|-----------|-----------|-----------|-----------|
| ARI** (years) | 5 min | 10 min | 15 min | 30 min | 60 min | 120 min | 3 hr | 6 hr | 12 hr | 24 hr | 48 hr | 4 day | 7 day | 10 day | 20 day | 30 day | 45 day | 60 day |
| 1 | 0.15 | 0.24 | 0.29 | 0.39 | 0.49 | 0.62 | 0.74 | 1.04 | 1.40 | 1.84 | 2.23 | 2.76 | 3.44 | 4.01 | 5.53 | 6.96 | 8.95 | 10.99 |
| 2 | 0.20 | 0.30 | 0.37 | 0.50 | 0.62 | 0.78 | 0.92 | 1.28 | 1.72 | 2.28 | 2.75 | 3.44 | 4.29 | 4.98 | 6.87 | 8.64 | 11.07 | 13.64 |
| 5 | 0.27 | 0.41 | 0.51 | 0.69 | 0.85 | 1.01 | 1.15 | 1.54 | 2.06 | 2.75 | 3.38 | 4.28 | 5.34 | 6.12 | 8.31 | 10.48 | 13.32 | 16.38 |
| 10 | 0.33 | 0.51 | 0.63 | 0.85 | 1.05 | 1.23 | 1.36 | 1.77 | 2.36 | 3.15 | 3.91 | 5.00 | 6.22 | 7.06 | 9.46 | 11.97 | 15.13 | 18.51 |
| 25 | 0.43 | 0.65 | 0.81 | 1.09 | 1.35 | 1.56 | 1.70 | 2.10 | 2.78 | 3.68 | 4.65 | 6.02 | 7.46 | 8.36 | 10.97 | 13.98 | 17.59 | 21.29 |
| 50 | 0.52 | 0.78 | 0.97 | 1.31 | 1.62 | 1.85 | 1.99 | 2.37 | 3.11 | 4.10 | 5.25 | 6.86 | 8.47 | 9.38 | 12.13 | 15.54 | 19.50 | 23.40 |
| 100 | 0.61 | 0.93 | 1.16 | 1.56 | 1.93 | 2.20 | 2.34 | 2.71 | 3.47 | 4.53 | 5.88 | 7.75 | 9.54 | 10.45 | 13.31 | 17.15 | 21.48 | 25.55 |
| 200 | 0.73 | 1.11 | 1.38 | 1.85 | 2.29 | 2.60 | 2.75 | 3.11 | 3.91 | 4.97 | 6.55 | 8.69 | 10.66 | 11.56 | 14.50 | 18.77 | 23.52 | 27.72 |
| 500 | 0.91 | 1.39 | 1.72 | 2.32 | 2.87 | 3.23 | 3.40 | 3.77 | 4.61 | 5.55 | 7.47 | 10.03 | 12.25 | 13.09 | 16.09 | 20.98 | 26.34 | 30.66 |
| 1000 | 1.08 | 1.65 | 2.04 | 2.75 | 3.41 | 3.81 | 3.99 | 4.36 | 5.16 | 6.01 | 8.22 | 11.12 | 13.54 | 14.32 | 17.34 | 22.69 | 28.63 | 32.98 |

| | | | | | | | | | | | | | | | | | | |
|------|------|------|------|------|------|------|------|------|------|------|------|------|-------|-------|-------|-------|-------|-------|
| 1 | 0.14 | 0.21 | 0.26 | 0.34 | 0.43 | 0.56 | 0.67 | 0.96 | 1.29 | 1.69 | 2.02 | 2.49 | 3.10 | 3.63 | 5.06 | 6.38 | 8.26 | 10.11 |
| 2 | 0.17 | 0.27 | 0.33 | 0.44 | 0.55 | 0.70 | 0.83 | 1.18 | 1.58 | 2.08 | 2.50 | 3.09 | 3.86 | 4.51 | 6.28 | 7.91 | 10.22 | 12.54 |
| 5 | 0.24 | 0.36 | 0.45 | 0.60 | 0.74 | 0.90 | 1.04 | 1.41 | 1.89 | 2.51 | 3.06 | 3.83 | 4.78 | 5.51 | 7.58 | 9.56 | 12.24 | 14.99 |
| 10 | 0.29 | 0.44 | 0.54 | 0.73 | 0.90 | 1.08 | 1.23 | 1.62 | 2.15 | 2.86 | 3.52 | 4.46 | 5.55 | 6.34 | 8.60 | 10.89 | 13.86 | 16.90 |
| 25 | 0.36 | 0.55 | 0.68 | 0.92 | 1.14 | 1.35 | 1.50 | 1.90 | 2.51 | 3.33 | 4.16 | 5.34 | 6.61 | 7.46 | 9.93 | 12.66 | 16.02 | 19.36 |
| 50 | 0.42 | 0.65 | 0.80 | 1.08 | 1.33 | 1.57 | 1.73 | 2.12 | 2.78 | 3.69 | 4.67 | 6.05 | 7.46 | 8.34 | 10.94 | 13.99 | 17.66 | 21.19 |
| 100 | 0.49 | 0.75 | 0.93 | 1.25 | 1.55 | 1.81 | 1.98 | 2.38 | 3.06 | 4.06 | 5.20 | 6.79 | 8.34 | 9.23 | 11.94 | 15.36 | 19.32 | 23.02 |
| 200 | 0.57 | 0.86 | 1.07 | 1.44 | 1.78 | 2.07 | 2.27 | 2.69 | 3.39 | 4.42 | 5.73 | 7.57 | 9.25 | 10.14 | 12.93 | 16.72 | 20.98 | 24.81 |
| 500 | 0.68 | 1.03 | 1.27 | 1.72 | 2.12 | 2.46 | 2.69 | 3.18 | 3.91 | 4.90 | 6.47 | 8.63 | 10.50 | 11.36 | 14.22 | 18.51 | 23.20 | 27.14 |
| 1000 | 0.77 | 1.17 | 1.45 | 1.95 | 2.41 | 2.78 | 3.04 | 3.59 | 4.30 | 5.26 | 7.04 | 9.47 | 11.49 | 12.29 | 15.20 | 19.86 | 24.92 | 28.90 |

* The lower bound of the confidence interval at 90% confidence level is the value which 5% of the simulated quantile values for a given frequency are less than.
 ** These precipitation frequency estimates are based on a partial duration maxima series. ARI is the Average Recurrence Interval.
 Please refer to NOAA Atlas 14 Document for more information. NOTE: Formatting prevents estimates near zero to appear as zero.

Text version of tables

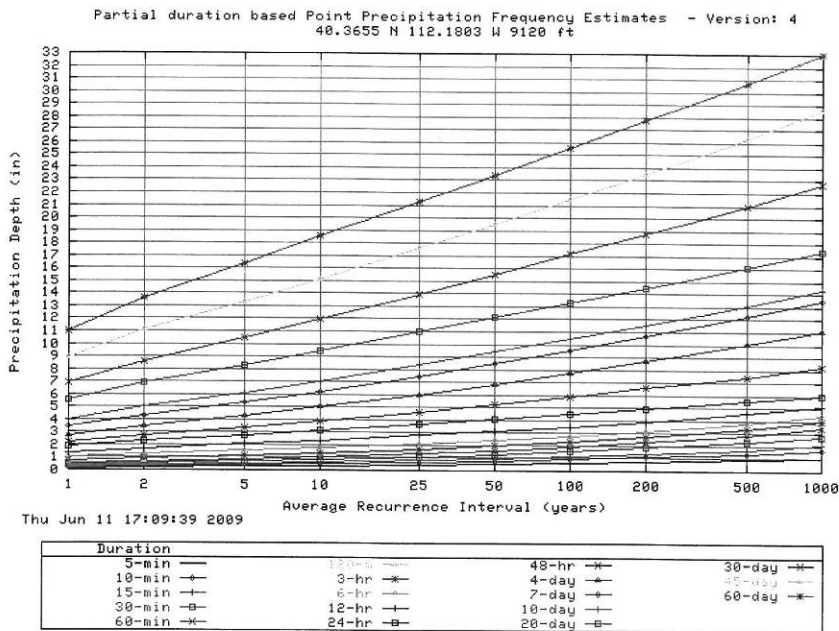

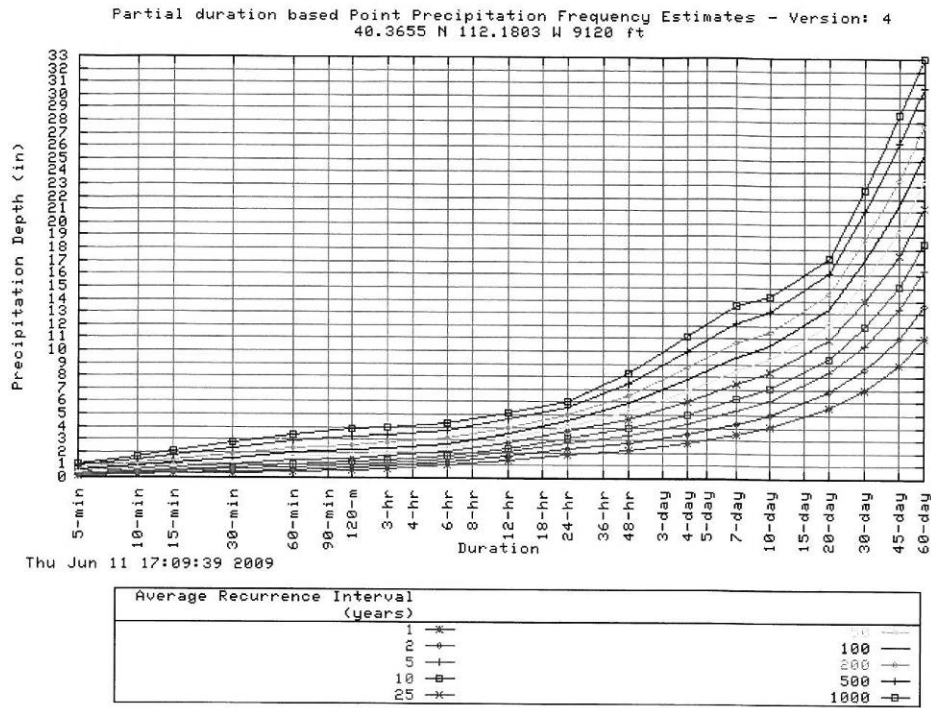

Maps -



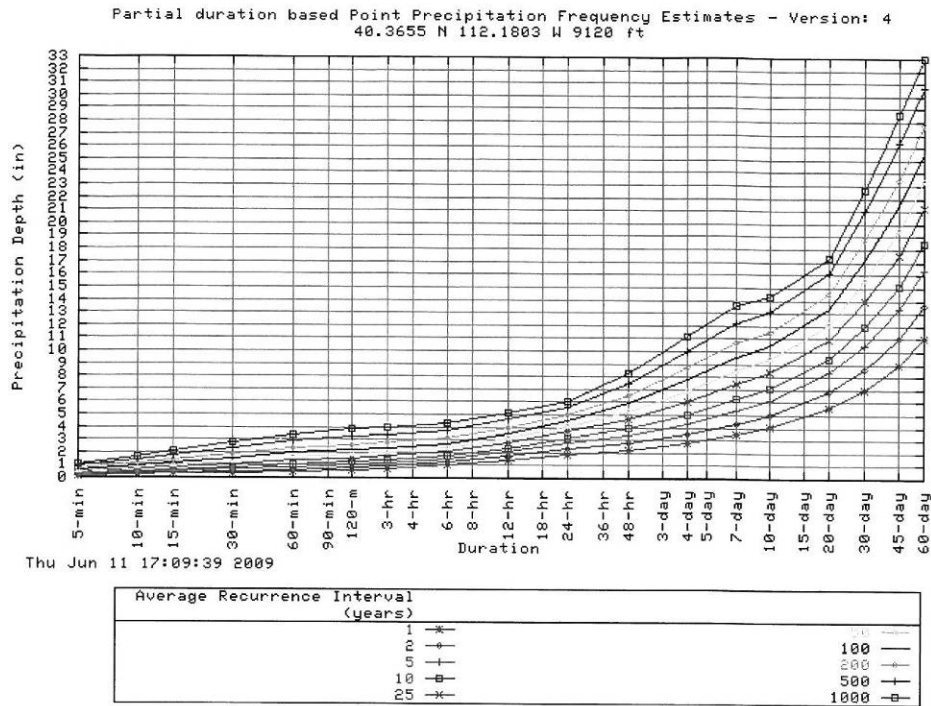

Maps -

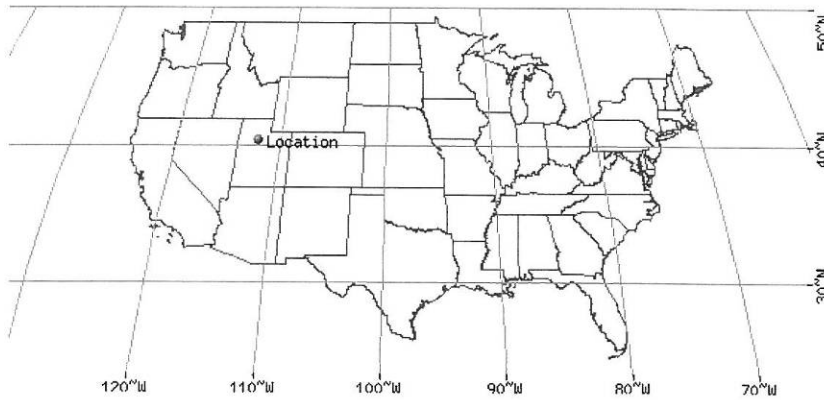

Appendix B – TR-55, Table 2-2

Chapter 2

Estimating Runoff

Technical Release 55
Urban Hydrology for Small Watersheds

Table 2-2a Runoff curve numbers for urban areas^{1/}

| Cover description | Average percent impervious area ^{2/} | Curve numbers for hydrologic soil group | | | |
|--------------------------------------------------------------------------------------------------------------------------------------------|--------------------------------------------------|--------------------------------------------|----|----|----|
| | | A | B | C | D |
| <i>Fully developed urban areas (vegetation established)</i> | | | | | |
| Open space (lawns, parks, golf courses, cemeteries, etc.) ^{3/} : | | | | | |
| Poor condition (grass cover < 50%) | | 68 | 79 | 86 | 89 |
| Fair condition (grass cover 50% to 75%) | | 49 | 69 | 79 | 84 |
| Good condition (grass cover > 75%) | | 39 | 61 | 74 | 80 |
| Impervious areas: | | | | | |
| Paved parking lots, roofs, driveways, etc. (excluding right-of-way) | | | | | |
| | | 98 | 98 | 98 | 98 |
| Streets and roads: | | | | | |
| Paved; curbs and storm sewers (excluding right-of-way) | | | | | |
| | | 98 | 98 | 98 | 98 |
| Paved; open ditches (including right-of-way) | | | | | |
| | | 88 | 89 | 92 | 93 |
| Gravel (including right-of-way) | | | | | |
| | | 76 | 85 | 89 | 91 |
| Dirt (including right-of-way) | | | | | |
| | | 72 | 82 | 87 | 89 |
| Western desert urban areas: | | | | | |
| Natural desert landscaping (pervious areas only) ^{4/} | | | | | |
| | | 68 | 77 | 85 | 88 |
| Artificial desert landscaping (impervious weed barrier, desert shrub with 1- to 2-inch sand or gravel mulch and basin borders) | | | | | |
| | | 96 | 96 | 96 | 96 |
| Urban districts: | | | | | |
| Commercial and business | | | | | |
| | 85 | 89 | 92 | 94 | 95 |
| Industrial | | | | | |
| | 72 | 81 | 88 | 91 | 93 |
| Residential districts by average lot size: | | | | | |
| 1/8 acre or less (town houses) | | | | | |
| | 65 | 77 | 85 | 90 | 92 |
| 1/4 acre | | | | | |
| | 38 | 61 | 75 | 83 | 87 |
| 1/3 acre | | | | | |
| | 30 | 57 | 72 | 81 | 86 |
| 1/2 acre | | | | | |
| | 25 | 54 | 70 | 80 | 85 |
| 1 acre | | | | | |
| | 20 | 51 | 68 | 79 | 84 |
| 2 acres | | | | | |
| | 12 | 46 | 65 | 77 | 82 |
| <i>Developing urban areas</i> | | | | | |
| Newly graded areas (pervious areas only, no vegetation) ^{5/} | | | | | |
| | | 77 | 86 | 91 | 94 |
| Idle lands (CN's are determined using cover types similar to those in table 2-2c). | | | | | |

¹ Average runoff condition, and $I_a = 0.2S$.

² The average percent impervious area shown was used to develop the composite CN's. Other assumptions are as follows: impervious areas are directly connected to the drainage system, impervious areas have a CN of 98, and pervious areas are considered equivalent to open space in good hydrologic condition. CN's for other combinations of conditions may be computed using figure 2-3 or 2-4.

³ CN's shown are equivalent to those of pasture. Composite CN's may be computed for other combinations of open space cover type.

⁴ Composite CN's for natural desert landscaping should be computed using figures 2-3 or 2-4 based on the impervious area percentage (CN = 98) and the pervious area CN. The pervious area CN's are assumed equivalent to desert shrub in poor hydrologic condition.

⁵ Composite CN's to use for the design of temporary measures during grading and construction should be computed using figure 2-3 or 2-4 based on the degree of development (impervious area percentage) and the CN's for the newly graded pervious areas.

Table 2-2b Runoff curve numbers for cultivated agricultural lands ¹

| Cover description | | Hydrologic condition ² | Curve numbers for hydrologic soil group | | | |
|------------------------------------------------------|----------------------------|-----------------------------------|-----------------------------------------|----|----|----|
| Cover type | Treatment ³ | | A | B | C | D |
| Fallow | Bare soil | — | 77 | 86 | 91 | 94 |
| | Crop residue cover (CR) | Poor | 76 | 85 | 90 | 93 |
| | | Good | 74 | 83 | 88 | 90 |
| Row crops | Straight row (SR) | Poor | 72 | 81 | 88 | 91 |
| | | Good | 67 | 78 | 85 | 89 |
| | SR + CR | Poor | 71 | 80 | 87 | 90 |
| | | Good | 64 | 75 | 82 | 85 |
| | Contoured (C) | Poor | 70 | 79 | 84 | 88 |
| | | Good | 65 | 75 | 82 | 86 |
| | C + CR | Poor | 69 | 78 | 83 | 87 |
| | | Good | 64 | 74 | 81 | 85 |
| | Contoured & terraced (C&T) | Poor | 66 | 74 | 80 | 82 |
| | | Good | 62 | 71 | 78 | 81 |
| C&T + CR | Poor | 65 | 73 | 79 | 81 | |
| | Good | 61 | 70 | 77 | 80 | |
| Small grain | SR | Poor | 65 | 76 | 84 | 88 |
| | | Good | 63 | 75 | 83 | 87 |
| | SR + CR | Poor | 64 | 75 | 83 | 86 |
| | | Good | 60 | 72 | 80 | 84 |
| | C | Poor | 63 | 74 | 82 | 85 |
| | | Good | 61 | 73 | 81 | 84 |
| | C + CR | Poor | 62 | 73 | 81 | 84 |
| | | Good | 60 | 72 | 80 | 83 |
| | C&T | Poor | 61 | 72 | 79 | 82 |
| | | Good | 59 | 70 | 78 | 81 |
| C&T + CR | Poor | 60 | 71 | 78 | 81 | |
| | Good | 58 | 69 | 77 | 80 | |
| Close-seeded or broadcast legumes or rotation meadow | SR | Poor | 66 | 77 | 85 | 89 |
| | | Good | 58 | 72 | 81 | 85 |
| | C | Poor | 64 | 75 | 83 | 85 |
| | | Good | 55 | 69 | 78 | 83 |
| | C&T | Poor | 63 | 73 | 80 | 83 |
| | | Good | 51 | 67 | 76 | 80 |

¹ Average runoff condition, and $I_a=0.2S$

² Crop residue cover applies only if residue is on at least 5% of the surface throughout the year.

³ Hydraulic condition is based on combination factors that affect infiltration and runoff, including (a) density and canopy of vegetative areas, (b) amount of year-round cover, (c) amount of grass or close-seeded legumes, (d) percent of residue cover on the land surface (good $\geq 20\%$), and (e) degree of surface roughness.

Poor: Factors impair infiltration and tend to increase runoff.

Good: Factors encourage average and better than average infiltration and tend to decrease runoff.

Table 2-2c Runoff curve numbers for other agricultural lands^{1/}

| Cover type | Cover description | Hydrologic condition | Curve numbers for hydrologic soil group | | | |
|------------------------------------------------------------------------------|-------------------|----------------------|-----------------------------------------|----|----|----|
| | | | A | B | C | D |
| Pasture, grassland, or range—continuous forage for grazing. ^{2/} | | Poor | 68 | 79 | 86 | 89 |
| | | Fair | 49 | 69 | 79 | 84 |
| | | Good | 39 | 61 | 74 | 80 |
| Meadow—continuous grass, protected from grazing and generally mowed for hay. | | — | 30 | 58 | 71 | 78 |
| Brush—brush-weed-grass mixture with brush the major element. ^{3/} | | Poor | 48 | 67 | 77 | 83 |
| | | Fair | 35 | 56 | 70 | 77 |
| | | Good | 30 ^{4/} | 48 | 65 | 73 |
| Woods—grass combination (orchard or tree farm). ^{5/} | | Poor | 57 | 73 | 82 | 86 |
| | | Fair | 43 | 65 | 76 | 82 |
| | | Good | 32 | 58 | 72 | 79 |
| Woods. ^{6/} | | Poor | 45 | 66 | 77 | 83 |
| | | Fair | 36 | 60 | 73 | 79 |
| | | Good | 30 ^{4/} | 55 | 70 | 77 |
| Farmsteads—buildings, lanes, driveways, and surrounding lots. | | — | 59 | 74 | 82 | 86 |

^{1/} Average runoff condition, and $I_a = 0.2S$.

^{2/} *Poor*: <50% ground cover or heavily grazed with no mulch.

Fair: 50 to 75% ground cover and not heavily grazed.

Good: > 75% ground cover and lightly or only occasionally grazed.

^{3/} *Poor*: <50% ground cover.

Fair: 50 to 75% ground cover.

Good: >75% ground cover.

^{4/} Actual curve number is less than 30; use CN = 30 for runoff computations.

^{5/} CN's shown were computed for areas with 50% woods and 50% grass (pasture) cover. Other combinations of conditions may be computed from the CN's for woods and pasture.

^{6/} *Poor*: Forest litter, small trees, and brush are destroyed by heavy grazing or regular burning.

Fair: Woods are grazed but not burned, and some forest litter covers the soil.

Good: Woods are protected from grazing, and litter and brush adequately cover the soil.

Table 2-2d Runoff curve numbers for arid and semiarid rangelands^{1/}

| Cover description Cover type | Hydrologic condition ^{2/} | Curve numbers for hydrologic soil group | | | |
|------------------------------------------------------------------------------------------------------------------------------------|---------------------------------------|--------------------------------------------|----|----|----|
| | | A ^{3/} | B | C | D |
| Herbaceous—mixture of grass, weeds, and low-growing brush, with brush the minor element. | Poor | | 80 | 87 | 93 |
| | Fair | | 71 | 81 | 89 |
| | Good | | 62 | 74 | 85 |
| Oak-aspen—mountain brush mixture of oak brush, aspen, mountain mahogany, bitter brush, maple, and other brush. | Poor | | 66 | 74 | 79 |
| | Fair | | 48 | 57 | 63 |
| | Good | | 30 | 41 | 48 |
| Pinyon-juniper—pinyon, juniper, or both; grass understory. | Poor | | 75 | 85 | 89 |
| | Fair | | 58 | 73 | 80 |
| | Good | | 41 | 61 | 71 |
| Sagebrush with grass understory. | Poor | | 67 | 80 | 85 |
| | Fair | | 51 | 63 | 70 |
| | Good | | 35 | 47 | 55 |
| Desert shrub—major plants include saltbush, greasewood, creosotebush, blackbrush, bursage, palo verde, mesquite, and cactus. | Poor | 68 | 77 | 85 | 88 |
| | Fair | 55 | 72 | 81 | 86 |
| | Good | 49 | 68 | 79 | 84 |

¹ Average runoff condition, and $I_p = 0.2S$. For range in humid regions, use table 2-2c.

² Poor: <30% ground cover (litter, grass, and brush overstory).

Fair: 30 to 70% ground cover.

Good: > 70% ground cover.

³ Curve numbers for group A have been developed only for desert shrub.

Pole Canyon

Water System Master Plan

Table of Contents

| | |
|-------------------------------------------------------|----------|
| TABLE OF CONTENTS | 2 |
| POLE CANYON WATER SYSTEM | 3 |
| INTRODUCTION | 3 |
| DEMOGRAPHIC AND POPULATION PROJECTION SUMMARY | 3 |
| POLE CANYON WATER SYSTEM | 4 |
| OVERVIEW | 4 |
| WATER SYSTEM INFRASTRUCTURE | 4 |
| <i>Water Storage and Source Capacities</i> | 4 |
| <i>Distribution System</i> | 6 |
| <i>Pressure Zones</i> | 6 |
| POLE CANYON WATER SYSTEM | 7 |
| ANALYSIS AND RECOMMENDATIONS | 7 |
| WATER RIGHT ANALYSIS..... | 7 |
| <i>Required Water Rights</i> | 8 |
| <i>Water Rights Balance</i> | 8 |
| <i>Recommended Water Rights</i> | 9 |
| WATER SOURCE ANALYSIS | 10 |
| <i>Required Source Capacity</i> | 10 |
| <i>Recommended Source Capacity</i> | 11 |
| SOURCE CAPACITY SUMMARY | 13 |
| WATER STORAGE ANALYSIS..... | 13 |
| <i>Required Storage Capacity</i> | 13 |
| <i>Recommended Storage Capacity</i> | 14 |
| WATER DISTRIBUTION ANALYSIS..... | 15 |
| <i>Distribution System</i> | 15 |
| <i>Pressure Zones</i> | 15 |
| SUMMARY OF WATER SYSTEM RECOMMENDATIONS | 16 |
| <i>Distribution System and Storage Upgrades</i> | 16 |
| EXISTING WATER SYSTEM INFRASTRUCTURE VALUATION | 21 |
| APPENDIX | 22 |

Pole Canyon Water System Introduction

The purpose of this water system master plan report is to provide a basis and guide for water system (both indoor domestic usage and outdoor irrigation usage) infrastructure improvements and to aid in the establishment of water related impact and connection fees for Pole Canyon.

The proposed development will require a significant number of infrastructure improvement projects but will also take advantage of existing facilities that are currently in use. The existing facilities were constructed between the late 1970's and 1980's and are all part of the White Hills Water System. These facilities, the storage tanks and well in particular, provide a good backbone for the proposed developments.

Demographic and Population Projection Summary

The current demographics and future population projections for Pole Canyon were prepared in conjunction with the overall master plan and were completed in the Demographic Analysis portion of this report. Current and future population projections to estimated build-out in year 2030 and corresponding Equivalent Residential Connections (ERC) are summarized in Table 1. It should be noted that the build-out year of 2030 is based on the population projections provided in the Demographics section of this report and is used as a reference for analyses contained in this report. Actual build-out could occur before or after this date.

Table 1 – Equivalent Residential Connections

| Total | | Current | | Future (YR 2030) | |
|------------|--------|------------|-----|------------------|--------|
| Population | ERC | Population | ERC | Population | ERC |
| 34,224 | 15,597 | 424 | 121 | 33,800 | 15,476 |

Pole Canyon Water System Overview

Water System Infrastructure

In order to establish a reasonable water impact fee, it is important to briefly review and understand the existing facilities that will become part of the Pole Canyon Water System. These existing facilities are all part of the existing White Hills Water System which includes water storage capacity, source capacity, and distribution system piping. This system is currently owned and operated by the White Hills Water Company. As development of the area progresses, it is anticipated that ownership and operational responsibilities may at some point be transferred to a new municipality, special service district or other body politic in the event of probable annexation(s) and/or other entitlement development(s).

Water Storage and Source Capacities

The source of all water for the development is groundwater withdrawn from the underlying alluvial aquifer from a single well, the Cook Well. While there are several other wells on the property, the Cook Well is the only well certified for indoor use and has a capacity of 3.0 cubic feet per second (cfs), or 1,345 gallons per minute (gpm). Water is pumped into two welded steel tanks with a combined capacity of 770,000 gallons and is supplied to residents of White Hills Subdivision through a network of steel and PVC distribution piping. It should be noted that the original developers of White Hills Subdivision constructed a 1 million gallon water storage tank in anticipation of development that never occurred. A booster pump station was built at the site of the two lower tanks to supply water to the higher 1 million gallon tank via a 10-inch steel pipeline, thus the total storage capacity is 1,770,000 gallons. There are approximately 10 additional homes located along Highway 73 that are connected to the White Hills system. A breakdown of the proposed development's existing water sources and storage tanks are summarized in Table 2 and shown in Figure 1.

Table 2 - Water System Storage and Source Capacity

| Storage Tanks | | Wells | |
|---------------|------------------|-----------------------|----------------|
| Name | Capacity (gal) | Name | Capacity (gpm) |
| Upper Tank | 1,000,000 | Cook Well | 1,345 |
| Lower Tank #1 | 220,000 | House (Back up) Well* | 70 |
| Lower Tank #2 | 550,000 | | |
| | | | |
| Total | 1,770,000 | Total | 1,345 |

* The House Well is not an approved culinary source

XXX_08/12/2008_X:\Pole Canyon\Master Plan\Storm Drainage\GIS\Pole Canyon - Existing water.mxd 08/12/08

1 MILLION GALLON STORAGE TANK

UPPER TANK BOOSTER PUMP

LOWER STORAGE TANKS
(0.22 & 0.77 MILLION GALLONS)

COOK WELL

HOUSE WELL*



Existing Pipelines

— <all other values>

Diameter

— 6"

— 8"

— 10"

- - - Development Boundary

● Storage Tank

□ Pump

Existing White Hills Subdivision

* NOT APPROVED FOR DRINKING WATER

| ORIGINAL | | DESIGN | | DRAWN | | CHECKED | |
|-----------|------------|--------|-----|-------|-----|---------|-----|
| NO. | DATE | DMH | DMH | MPM | MPM | DMH | DMH |
| 1 | 08/12/2008 | | | | | | |
| REVISIONS | | DESIGN | | DRAWN | | CHECKED | |
| NO. | DATE | DMH | DMH | MPM | MPM | DMH | DMH |
| | | | | | | | |

POLE CANYON DEVELOPMENT
POLE CANYON UTILITY MASTER PLAN
CULINARY WATER ANALYSIS
WHITE HILLS WATER COMPANY - EXISTING SYSTEM

AQUA
ENGINEERING, INC.
 533 W. 2600 S., SUITE 275 BOUNTIFUL, UT 84010
 PHONE (801) 288-1327 FAX (801) 289-0153

FIGURE
1

Distribution System

As stated previously, the existing distribution system located within the Pole Canyon development area is part of the existing White Hills Water System. The pipe materials consist of steel and PVC and range in size from 6-inch to 10-inch.

Pressure Zones

Currently, there are only 2 pressure zones in the system. These zones represent areas in the water distribution system where acceptable residential pressures, typically between 50 and 100 psi, are maintained by pressure reducing valves (PRV). The only known PRV in the system is located at the end of the 10-inch line that supplies the homes on the west side of Highway 73. This PRV establishes the second pressure zone in the system. The upper tank is not directly connected to the distribution system but rather supplies water to the lower tanks only, thus the lower tanks establish the current pressure zones. It is anticipated that proposed improvements will connect the upper tank directly to the water system requiring the installation of several PRV stations to maintain mainline pressures between 50 and 100 psi.

Pole Canyon Water System Analysis and Recommendations

Water Right Analysis

Pole Canyon has 2,780 acre-feet of water rights as of the beginning of 2008. A transfer of 1,200 acre-feet to Eagle Mountain City is currently in process leaving a useful total of 1,580 acre-feet. According to Utah Division of Water Rights information, approximately 175 acre-feet of these rights are classified as domestic use while the remaining 1,405 acre-feet are classified as either stock watering or irrigation rights. It should be noted that in Cedar Valley, conversion of stock and irrigation water rights to domestic or municipal use takes place on a 1:1 ratio with 100% depletion, thus the entire 1,580 acre-feet can be used to calculate the number of ERC that can be supported by the existing water rights. Based on the State's 0.45 acre-feet per ERC indoor use requirement 3,525 ERC can be supported by the existing rights.

For the purposes of estimating the necessary outdoor water right requirement and sizing infrastructure, an average lot size must be determined and assigned an appropriate irrigated acreage. This is determined by first calculating the average lot size for the development and then applying the correct usage requirement per State guidelines. In the case of Pole Canyon, the average gross density of the Neighborhood Planning Areas (NPA) and the Mixed-use Planning Area (MUPA) is 5.0 ERC per acre which corresponds most closely to $\frac{1}{5}$ acre lots after allowances for roads, sidewalk and infrastructure are made. Pole Canyon is located in zone 4 according to the Utah Irrigated Crop Consumptive Use Zones which requires 1.87 acre-feet per irrigated acre per year. Typically, a $\frac{1}{5}$ acre building lot has approximately 3,000 square feet (0.075 acre) of irrigated area in the form of turf, flower gardens or other vegetation. Multiplying the 0.075 irrigated acreage per lot by 1.87 acre-feet per irrigated acre gives the outdoor use requirement per average lot of approximately 0.14 acre-feet. This is the value that will be used in this report for planning purposes.

However, development within Pole Canyon will emphasize water conservation particularly with outdoor water use. This will be accomplished either through development covenants, conditions & restrictions (CCRs), deed restriction, and/or plat restriction. In essence, each parcel of land will be assigned an amount of acreage that will be allowed to be irrigated. This irrigated acreage is not necessarily related to lot size and will vary throughout the development. The following table generally illustrates the assignable irrigated acreage sizes and gives allotted water for outdoor use.

Table 3 – Assignable Irrigated Acreage

| Irrigated Acreage (Sq. Ft.) | Irrigated Acreage (Acre) | Outdoor Water Demand (Ac-Ft) |
|-----------------------------|--------------------------|------------------------------|
| 2,000 | 0.05 | 0.09 |
| 3,000 | 0.075 | 0.14 |
| 4,000 | 0.09 | 0.17 |
| 6,000 | 0.14 | 0.26 |
| 8,000 | 0.18 | 0.34 |
| 10,000 | 0.23 | 0.43 |
| 12,500 | 0.29 | 0.54 |
| 15,000 | 0.34 | 0.64 |
| 17,500 | 0.40 | 0.75 |
| 21,500 | 0.50 | 0.92 |

Required Water Rights

The annual Indoor Water Right Requirement is calculated by multiplying the number of ERCs by the 0.45 acre-feet per ERC.

$$ERC \times 0.45 \text{ Acre-Feet/ERC} = \text{Total Indoor Requirement (Acre-Feet)}$$

The annual Outdoor Water Right Requirement is calculated by multiplying the number of ERCs by 0.14 acre-feet per year per ERC.

$$ERC \times 0.14 \text{ Acre-Feet/ERC} = \text{Total Outdoor Requirement (Acre-Feet)}$$

The required water rights for Pole Canyon based on demands from current ERC's and future projected ERC's are shown in Table 4.

Table 4 – Indoor and Outdoor Water Right Requirements

| Year | ERC | Indoor Demand (Ac-Ft) | Outdoor Demand (Ac-Ft) | Total Demand (Ac-Ft) | Current Capacity (Ac-Ft) | Surplus / Deficit (Ac-Ft) |
|---------------------|--------|-----------------------|------------------------|----------------------|--------------------------|---------------------------|
| Current (YR 2008) | 121 | 55 | 17 | 72 | 1,580 | 1,508 |
| Build-out (YR 2030) | 15,597 | 7,019 | 2,184 | 9,203 | 1,580 | (7,623) |

Water Rights Balance

It is beneficial to know the extent of development that can take place based on the existing water rights. This water rights balance will show how many ERC can be developed assuming the above parameters of 0.45 acre-feet per ERC indoor use and 0.14 acre-feet per ERC outdoor use. Currently, there are 121 ERC that use approximately 72 acre-feet of the existing water rights leaving a surplus of 1,508

acre-feet attributable to new growth. The past outdoor usage for White Hills Subdivision has been greater per lot due to the fact that the average lot size is greater. As illustrated above Pole Canyon Development plans implement water conservation measures which will reduce water usage per lot. Additional ERC given in Table 5 represents ERC that could be developed in addition to the 121 existing ERC based on current water rights.

Table 5 – Water Rights Balance

| Additional ERC | *Indoor Use Req. (acre-ft.) | Outdoor Use Req. (acre-ft.) | Surplus Rights (acre-ft.) |
|-----------------------|------------------------------------|------------------------------------|----------------------------------|
| 2,550.00 | 1147.50 | 357.00 | 3.50 |
| 2,555.00 | 1149.75 | 357.70 | 0.55 |
| 2,560.00 | 1152.00 | 358.40 | -2.40 |
| 2,565.00 | 1154.25 | 359.10 | -5.35 |

**Additional ERC assumes all stock and irrigation rights can be converted to municipal use on a 1:1 basis without any depletion requirement.*

Table 4 illustrates that approximately 2,555 ERC could be developed by balancing the outdoor and indoor use requirements against surplus water rights. These 2,555 ERC are in addition to the existing 121 ERC in White Hills Subdivision. Based on population projections from the Demographics Analysis, this would occur approximately in the year 2015.

Recommended Water Rights

As previously stated the total water rights currently owned by Pole Canyon are 1,580 acre-feet. As expressed in Table 3, the current total demand is 72 acre-feet thus the surplus is 1,508 acre-feet. In the year 2030, the estimated build-out water right requirement will be approximately 9,203 acre-feet yielding a 7,623 acre-foot deficit. It should be noted that Pole Canyon has requested 5,500 acre-feet of water from Central Utah Water Conservancy District (CUWCD) as part of the Central Utah Water Project (CWP) to cover this deficit. The additional acre-footage requested has been earmarked for use in the Pole Canyon Business Park. At this point, it is somewhat uncertain the amount of water demand that will be required within the business park as this is completely depended on the type of industry that locates here. An additional 2,200 may need to be requested.

Pole Canyon water right status is shown graphically in Figure 2. As shown, current water rights will provide for 2,676 ERC which will be reached in the year 2016 according to projections.

Figure 2 - Indoor and Outdoor Water Right Requirements

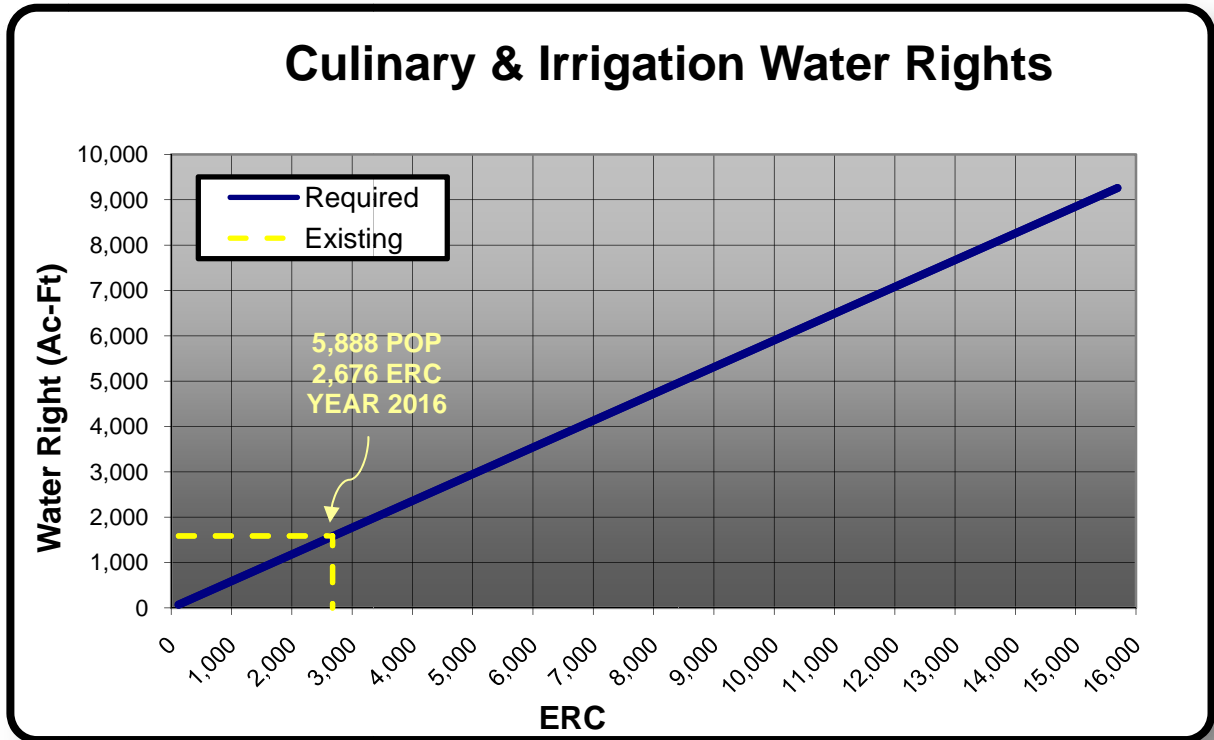

Water Source Analysis

In accordance with The State of Utah Administrative Codes for Public Drinking Water Systems, R309-510 requires community water systems to provide adequate water to satisfy peak day water demands for indoor and outdoor use. For indoor use each ERC, the minimum indoor use per connection per day is 800 gallons. For outdoor use each irrigated acre, the minimum outdoor use per connection per day is 3.96 gallons per minute (gpm).

Required Source Capacity

The Indoor Source Capacity is calculated by multiplying the number of ERC by the minimum 800 gallon per ERC requirement, then multiplying by 1 day (1440 minutes).

$$ERC \times 800 \text{ gal/day-ERC} \times 1 \text{ day}/1,440 \text{ minutes} = \text{Indoor Use (gpm)}$$

The Outdoor Source Capacity is calculated by multiplying the number of irrigated acres per ERC by the minimum 3.96 gallons per minute per irrigated acre requirement.

$$\text{Irrigated Acres per ERC} \times \text{Total number of ERC} \times 3.96 \text{ gallons per minute} = \text{Outdoor Use (gpm)}$$

The average gross density of Pole Canyon is 5.72 ERC per acre. Assuming 80 percent of the land to be developable and an average of 43 percent of the lot size to be irrigable, equates to 0.075 of an acre per ERC. Combining the required outdoor and indoor use from above, each ERC requires approximately 0.85 gpm source capacity. The required source capacities for Pole Canyon based on current conditions and projected future ERCs are given in Table 6.

Table 6 – Required Source Capacity

| Year | ERC | Indoor Demand (gpm) | Outdoor Demand (gpm) | Current Capacity (gpm) | Surplus / Deficit (gpm) |
|---------------------|--------|---------------------|----------------------|------------------------|-------------------------|
| Current (YR 2008) | 121 | 67 | 36 | 1,345 | 1,239 |
| Build-out (YR 2030) | 15,597 | 8,665 | 4,633 | 1,345 | (11,953) |

Recommended Source Capacity

As outlined in Table 2, the current indoor water source capacity for Pole Canyon is 1,345 gpm. From Table 5, the current water demand of 103 gpm results in a surplus of 1,239 gpm. With the Cook Well producing its rated capacity of 3.0 cfs (1,345 gpm) the current surplus should be adequate for the addition of approximately 1,458 ERC based on state source requirements. At build-out, or approximately 15,597 ERC, the total demand is estimated to be 13,298 gpm for a future deficit of 11,953 gpm. As stated previously, Pole Canyon has requested additional water from the CUWCD. Table 7 provides an anticipated delivery schedule of this water.

Table 7 – Estimated CWP Water Schedule

| Year | Estimated Water Demand | | Year | Estimated Water Demand | |
|------|------------------------|-----|------|------------------------|-----|
| | Acre-feet | gpm | | Acre-feet | gpm |
| 2012 | 60 | 37 | 2018 | 500 | 310 |
| 2013 | 100 | 62 | 2019 | 500 | 310 |
| 2014 | 200 | 124 | 2020 | 500 | 310 |
| 2015 | 280 | 174 | 2025 | 1500 | 930 |
| 2016 | 330 | 205 | 2030 | 1130 | 701 |

When CWP water is made available, it will be delivered through existing water distribution piping currently routed through existing communities located on the east side of Cedar Valley. Due to the west-side location of Pole Canyon and cost of distribution pipeline infrastructure, it makes sense to leave this water on the east side of the valley and exchange it via point of diversion change applications for ground water rights to be developed on the west side of Cedar Valley in the form of groundwater wells. This approach will accomplish two main goals; first, it will save the expense of miles of large diameter distribution line along with problems and costs associated with cross-country pipeline installations and maintenance, and second, it will allow much better control of water resources to the west side of Cedar Valley as development progresses. *Although this system would not initially be physically interconnected to piping on the east side of Cedar Valley, it is*

anticipated that as development fills in the land between Pole Canyon and Eagle Mountain, an interconnect would be established and paid for by impact fees collected from said development. It is important to note that in the interim water rights be arranged such that all points of diversion be combined, thus creating flexibility in source supply and allowing the total allotted water right to be pulled from any combination of wells within the system. Exchanges and changes in points of diversion of water rights with local governments/municipalities would be made concurrently with the deliveries of anticipated CWP water.

Following this proposed method of water source planning, it is recommended the Cook well be utilized until development necessitates the construction of additional well capacity, which as stated previous would be approximately in the year 2015. It is assumed that the operator of the water system would have a spare pump and equipment on-hand to change-out or remedy any issue that might arise with the pump in a timely manner. Source capacity could then be constructed on an as-needed basis to support development. Figure 3 is a graphical representation of estimated required source demand verses available source capacity assuming the CWP water is made available.

Figure 3 - Indoor Source Capacity with Estimated CWP Water

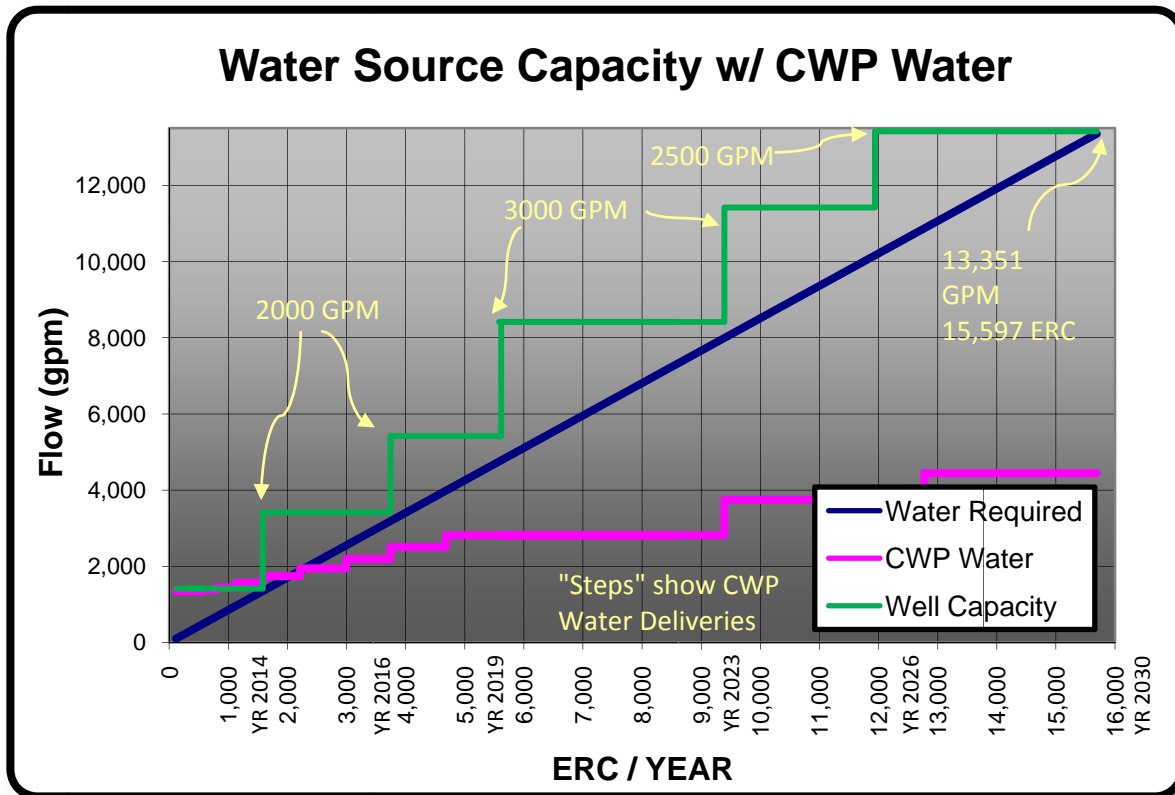

As stated, it will be necessary develop groundwater sources on the west side of Cedar Valley to accommodate future growth and transfer/exchange the right to use future CWP water rights for these groundwater rights. In the case that CWP water is not made available, the wells will still be required to provide adequate

source water for the proposed development in Pole Canyon. It should be noted that water rights acquisition for this situation should approximately follow the source capacity development to avoid any disruptions in service.

Source Capacity Summary

As stated, it is anticipated that CWP water will be available in the future to the east side of Cedar Valley. This water would be transferred/exchanged with local municipalities that can immediately use the water through existing distribution systems in exchange for groundwater rights to be developed on the west side of the valley. Table 8 lists the anticipated well development within Pole Canyon.

Table 8 – Recommended Source Capacity Infrastructure

| Source Capacity Infrastructure | Additional Flow (gpm) | *Total Flow Available (gpm) | ERC | Approx. Construction Year |
|--------------------------------|-----------------------|-----------------------------|--------|---------------------------|
| Well 1 | 2,000 | 3,415 | 3,744 | 2015 |
| Well 2 | 2,000 | 5,415 | 5,617 | 2017 |
| Well 3 | 3,000 | 8,415 | 9,392 | 2019 |
| Well 4 | 3,000 | 11,415 | 12,777 | 2023 |
| Well 5 | 2,000 | 13,415 | 15,597 | 2026 |

**Total Flow Available includes existing source capacity of 1,415 gpm from the Cook Well and backup House Well.*

Water Storage Analysis

Communities in Utah are required to provide adequate water storage capacity to satisfy both indoor and outdoor average day water demands. In addition to indoor use requirements, Pole Canyon must provide for fire suppression storage, as stated in the Utah State Administrative Codes for Public Drinking Water Systems R309-510. The indoor storage requirement is 400 gallons per ERC. The outdoor storage requirement is 2,848 gallons per irrigated acre.

It is proposed that fire suppression requirements match those of the surrounding communities, thus equaling a sustained fire protection flow of 1,750 gpm for 2 hours. This equates to a total fire protection storage requirement of 210,000 gallons.

Required Storage Capacity

The Indoor Storage Capacity is determined by multiplying the number of ERC by the minimum 400 gallon per ERC requirement.

$$ERC \times 400 \text{ gal/ERC} = \text{Indoor Use (gallons)}$$

The Outdoor Storage Capacity is determined by multiplying the number of irrigated acres per ERC by the minimum 2,848 gallons per irrigated acres requirement.

$$0.075 \text{ Irrigated acres per ERC} \times \text{Total number of ERC} \times 2,848 \text{ gallons per irrigated acres} = \text{Outdoor Use (gallons)}$$

The new fire protection volume is the required flow rate of 1,750 gpm multiplied by 2 hours (120 minutes).

$$1,750 \text{ gpm} \times 120 \text{ minutes} = \text{Fire Protection (gallons)}$$

The required storage capacity for Pole Canyon based on current and future ERC are given in Table 9.

Table 9 – Indoor, and Fire Flow Water Storage Capacity

| Year | ERC | Indoor Demand (gallons) | Outdoor Demand (gallons) | Fire Protection (gallons) | Total Demand (gallons) | Current Capacity (gallons) | Surplus / Deficit (gallons) |
|---------------------|--------|-------------------------|--------------------------|---------------------------|------------------------|----------------------------|-----------------------------|
| Current (YR 2008) | 121 | 48,400 | 25,846 | 210,000 | 234,246 | 1,770,000 | 1,485,754 |
| Build-out (YR 2030) | 15,597 | 6,238,800 | 3,331,520 | 210,000 | 9,780,320 | 1,770,000 | (8,010,320) |

Recommended Storage Capacity

Pole Canyon currently has the ability to store 1,770,000 gallons. As shown above in Table 9, the current storage requirement is 234,246 for a net surplus of 1,485,754 gallons. Using State storage requirement estimates, the current storage capacity should be adequate until approximately 2015 or the addition of 2,068 ERC. In the year 2030, the storage requirement will be approximately 9,780,320 equaling a net storage deficit of 8,010,320 gallons. As shown in Figure 4, an additional 8.2 million gallons of storage capacity will be required for proposed build-out population projections.

Figure 4 – Indoor and Fire Flow Water Storage Capacity

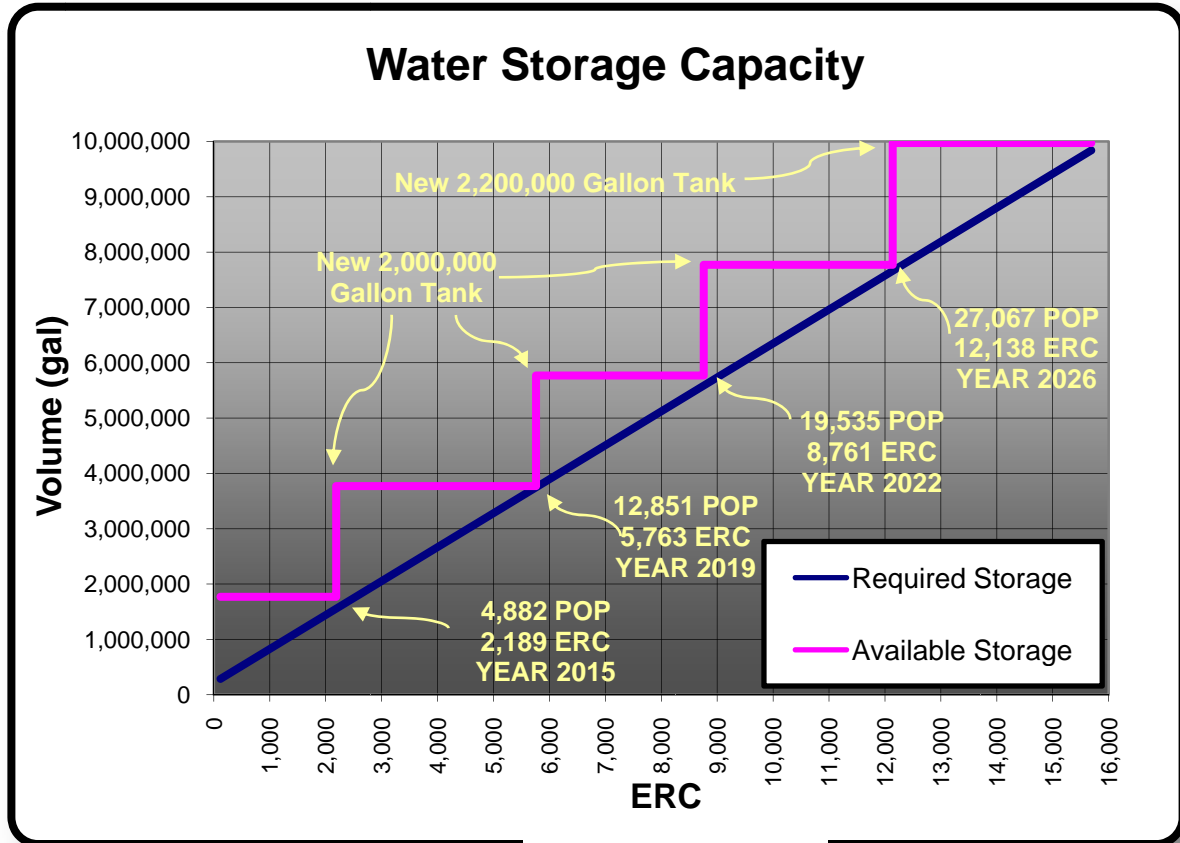

Water Distribution Analysis

Distribution System

In accordance with Utah State Administrative Codes for Public Drinking Water Systems, distribution systems are to be sized to supply indoor and outdoor peak instantaneous demand flows and while also maintaining fire flow at a minimum working pressure of at least 20 psi. Generally system pressures should be operated from between 50 psi and 90 psi during normal conditions. The distribution design parameters are shown in Table 10.

Pressure Zones

As stated previously, there are currently two pressure zones within the Pole Canyon development property. With the connection of the upper tank to the system, additional pressure zones will be implemented with the construction and installation of pressure reducing valves. Aqua Engineering has developed a water distribution model to determine changes in system pressures under peak day demands, including fire flow, while maintaining a minimum of 50 psi throughout the system under normal peak flow conditions and 20 psi under fire flow conditions as per state requirement. Location of future PRVs in the system and resulting pressure zones are shown in Figure 6. Pole Canyon includes a large light

industrial section and occasionally these users require higher water pressure than do residential users. If this is necessary, normal operating pressures in excess of 100 psi can be maintained in these areas by adjustment of PRV settings and/or locations of the actual PRV. It should be noted that residential users that are connected to higher pressure pipelines (80 psi and higher) may need to install an inline pressure reducing valve in their individual water service connection to reduce the water pressure to the home to a normal 45 to 60 psi. Detailed results of the modeling effort will be provided in the appendix.

Table 10 - Water Distribution System: Projected Design Parameters

| Design Parameters | | | |
|--------------------------------------------------------------------------------|--|--------------------------------------------------------------------------------|-------------------------------------------------------------|
| Average Daily Use | | | |
| Outdoor | | Indoor | Total |
| 3.96 gpm/irrigated acres 0.075 acres/ERC 0.297 gpm/ERC 427.68 gpd/ERC | | 400 gpd/ERC 0.278 gpm/ERC | 827.68 gpd/ERC 0.575 gpm/ERC |
| Peak Day Use | | | |
| Out Door | | Indoor | Total |
| 3.96 gpm/irrigated acres 0.075 acres/ERC 0.297 gpm/ERC 427.68 gpd/ERC | | 800 gpd/ERC 0.556 gpm/ERC | 1227.68 gpd/ERC 0.853 gpm/ERC 1.483 Demand Multiplier |
| Peak Hour (Instantaneous / Sizing) | | | |
| Out Door | | Indoor | Total |
| 7.92 gpm/irrigated acres 0.075 acres/ERC 0.594 gpm/ERC 855.36 gpd/ERC | | 1000 gpd/ERC 0.694 gpm/ERC 2.5 Peaking Factor 400 gpd/ERC Average Day | 1855.36 gpd/ERC 1.288 gpm/ERC 2.242 Demand Multiplier |

Summary of Water System Recommendations

Distribution System, Source, and Storage Upgrades

The development of Pole Canyon will require several water system upgrades as well as new facilities to accommodate proposed growth. The implementation of each project will be timed to both adequately handle new growth and to assist in providing required system capacity as stated in previous sections of this report. However, a major strength of the development is the existence of the utility infrastructure within White Hills Subdivision. This infrastructure was originally designed to accommodate several phases of White Hills Subdivision although only one phase was finished. Thus, much of the piping is oversized for existing usage

demands which, in turn, provides immediate system capacity for proposed development in Pole Canyon. In particular, the main 10" water main that provides water to White Hills from the existing tanks. This line has an average capacity of approximately 3.5 cfs (1,570 gpm) or the equivalent of 1,219 ERC of which only 121 ERC are currently connected. Using this data, the 10" main line will reach capacity in approximately the year 2015 at a projected population of 4,266 persons. Preliminary construction phasing within Pole Canyon has been planned such that the initial development can be served by this 10" main line. This development includes a residential section located immediately east of the existing lower tanks and west of White Hills Subdivision and an industrial section located east of the existing wastewater treatment lagoons. The residential section will be serviced by the upper tanks through the existing 10" main to maintain sufficient residential pressures while the proposed industrial section will be serviced through the 10" main from the lower tanks. Several small projects such as pressure reducing stations, a tank bypass on the lower tanks, and connecting piping will be required to accommodate the use of the 10" main lines as stated. The estimated cost for these projects is \$1,518,856.25. A detailed breakdown of the costs is included in the appendix and titled Phase 1 – Water System Infrastructure.

Currently, the Cook Well provides all the indoor use water to the White Hills Subdivision. However, due to deteriorating conditions, the building, pumps, controls, electrical and telemetry equipment will need to be upgraded to meet and comply with Eagle Mountain standards. A chlorine disinfection injection system will also need to be added to the system when the physical connection of the White Hills Subdivision system is made with the Eagle Mountain culinary system or if the source fails biological testing. When the chlorine disinfection system is installed, at an estimated date of 2022, or the existing building becomes structurally unsound, a new chlorination building will be constructed to house the chlorine disinfection system. The cost estimate of these upgrades are found in the appendix.

Future or additional development sections will require the construction of numerous water system piping projects which are shown in Table 10. It is very difficult, if not impossible to accurately determine construction phasing for a project of this size and scope. Therefore, it is not the intent of this report to assign development phasing as it pertains to water system utilities. However, in order to aide in the calculation of current and future year construction costs, it is necessary to establish a conceptual utility construction phase diagram. Figure 6 graphically depicts a reasonable conceptual utility construction phasing diagram from which costs and construction priorities have been assigned. Again, this diagram is conceptual in nature and the dates and priorities of each project can and will vary from those shown. *It should also be noted that several of the larger sized distribution lines would be built as parallel lines. For example, the developer may choose to install two 12" lines in parallel (in place of one 18") with one line being installed initially to serve proposed development within the reasonable future. The remaining 12" line would be installed at a later date when and if required by further development. It should be determined at the time of design and construction which diameter lines would be hydraulically equivalent to the lines proposed in the master plan to ensure the required ultimate flow can be met. This method of*

meeting immediate demand while maintaining flexibility in the system is beneficial in that it saves operation and maintenance costs due to smaller line sizes and does not tie up funds with unnecessary capacity.

As development progresses, the water system model provided with this master plan should be consulted and revised as needed when a significant change is made in the concept plan. This will assure that any change will not adversely affect the development as a whole and will ensure efficient water system function throughout the development. Table 10 provides a cost estimate summary including an estimated year of construction for the projects shown in Figure 6. The estimated year of construction should be viewed as a basis only to provide "Construction Year" cost to account for inflation over the course of the project. All upgrades are system upgrades and should be attributable to growth and thus impact fee eligible.

A more detailed current value cost estimate for each of these projects has been included in the appendix. Future construction costs have been projected assuming an estimated three percent per year for inflation and are shown in the construction year cost column in Table 10. Current dollar construction costs required for all upgrades to the system until build-out is reached (estimated YR 2030) are calculated at \$24,345,068.75.

M:\M - 10000\2000 - Pole Canyon Water Plant\Screen Drain\451077-Pole Canyon - Pre-prod water model - 100000

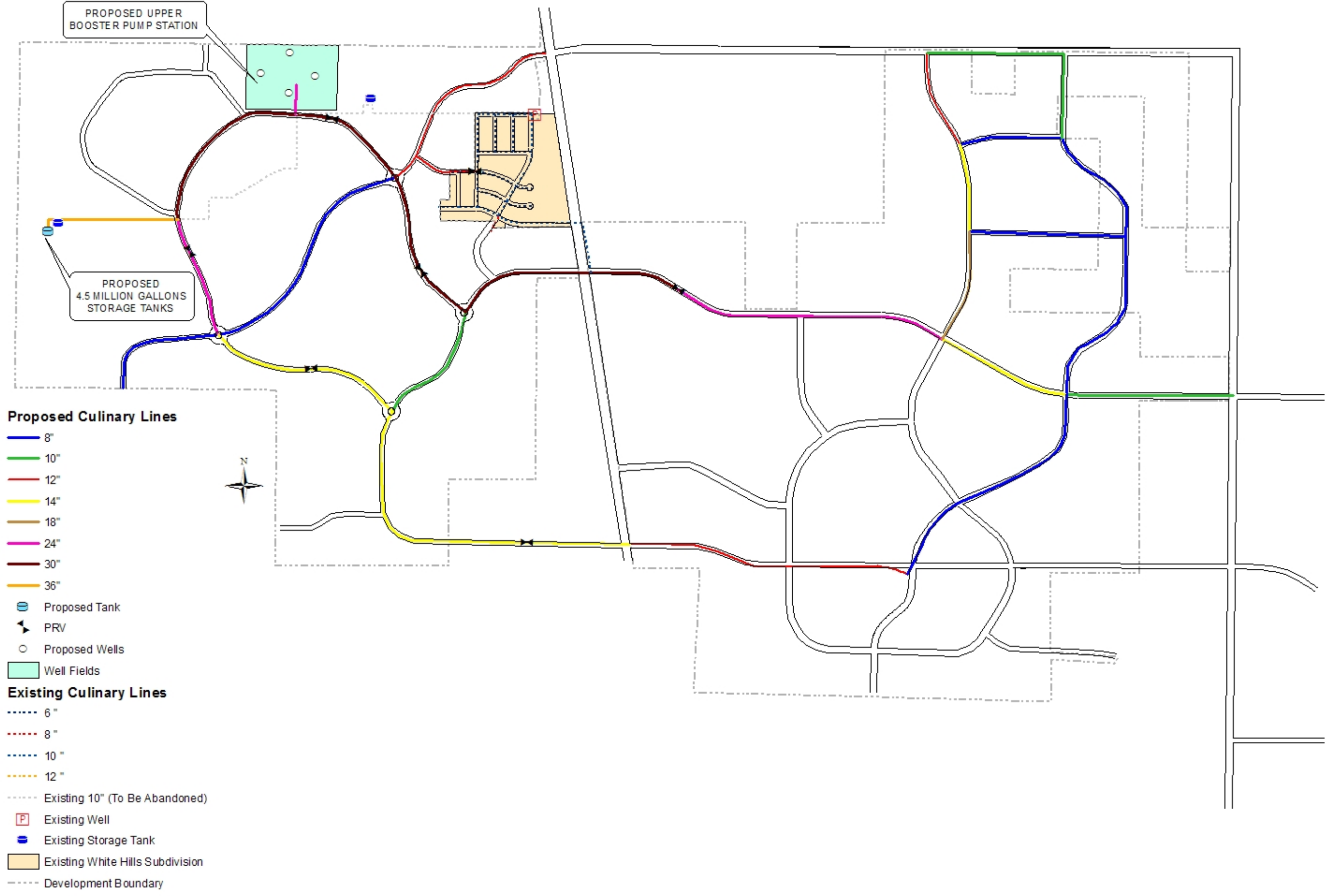

Proposed Culinary Lines

- 8"
- 10"
- 12"
- 14"
- 18"
- 24"
- 30"
- 36"

- Proposed Tank
- ▲ PRV
- Proposed Wells
- Well Fields

Existing Culinary Lines

- 6"
- 8"
- 10"
- 12"
- Existing 10" (To Be Abandoned)
- P Existing Well
- Existing Storage Tank
- Existing White Hills Subdivision
- Development Boundary

| ORIGINAL | | REVISIONS | |
|----------|----------|-----------|---------|
| NO. | DATE | DESIGN | CHECKED |
| 1 | 01/20/00 | DMH | DMH |
| | | | |
| | | | |
| | | | |

POLE CANYON DEVELOPMENT
 POLE CANYON UTILITY MASTER PLAN
 CULINARY WATER ANALYSIS
 PROPOSED CULINARY WATER SYSTEM

AQUA
 ENGINEERING, INC.
 553 W. 2600 S., SUITE 275 BOUNTIFUL, UT 84010
 PHONE (801) 298-1327 FAX (801) 298-0153

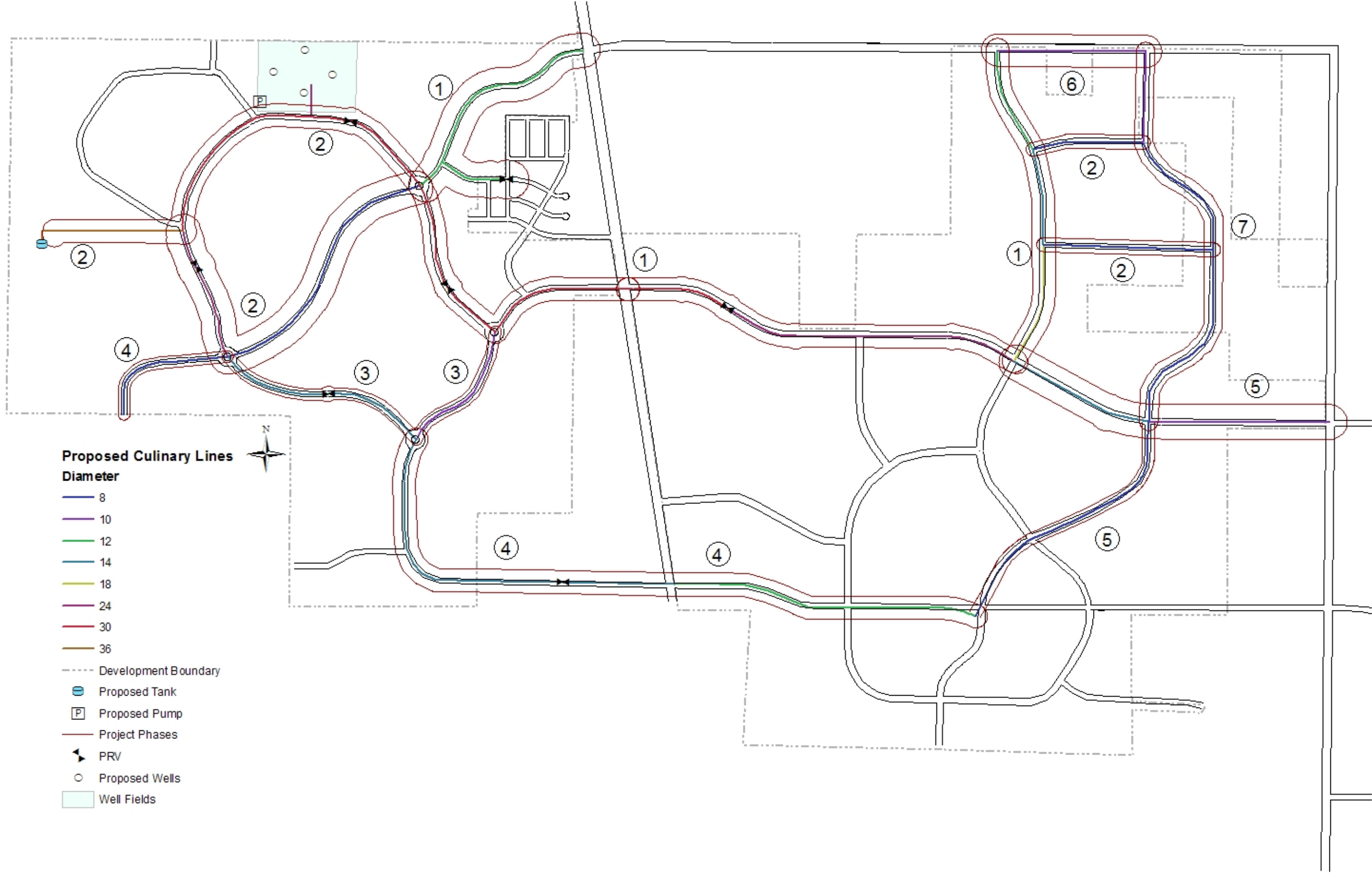

**Proposed Culinary Lines
Diameter**

- 8
- 10
- 12
- 14
- 18
- 24
- 30
- 36

- Development Boundary
- Proposed Tank
- Proposed Pump
- Project Phases
- ▲ PRV
- Proposed Wells
- Well Fields

| ORIGINAL | | DESIGN | DRAWN | CHECKED |
|-----------|----------|--------|-------|---------|
| NO. | DATE | DATE | DATE | DATE |
| 1 | 10/12/00 | DMH | MPM | DMH |
| REVISIONS | | | | |
| | | | | |
| | | | | |
| | | | | |

POLE CANYON DEVELOPMENT
 POLE CANYON UTILITY MASTER PLAN
 CULINARY WATER ANALYSIS
 PROPOSED PHASES - NEW CULINARY DISTRIBUTION

AQUA
 ENGINEERING, INC.
 553 W. 2600 S., SUITE 275 BOUNTIFUL, UT 84010
 PHONE (801) 298-1327 FAX (801) 298-0153

Table 10 - Water System Projects: Estimated Construction Costs

| Project | System Component | Approximate Year of Construction | Approximate ERC Capacity | Current Year Cost | Construction Year Cost |
|---------------------------------------|------------------|----------------------------------|--------------------------|------------------------|------------------------|
| Phase 1 - Water System Infrastructure | Distribution | 2009 | 279 | \$ 1,518,856.25 | \$ 1,518,856.25 |
| Phase 2 - Water System Infrastructure | Distribution | 2010 | 398 | \$ 3,151,725.00 | \$ 3,246,276.75 |
| Phase 3 - Water System Infrastructure | Distribution | 2012 | 809 | \$ 413,100.00 | \$ 450,279.00 |
| Phase 4 - Water System Infrastructure | Distribution | 2013 | 1,132 | \$ 845,375.00 | \$ 946,820.00 |
| Well #1 | Source | 2014 | 1,585 | \$ 475,650.00 | \$ 546,997.50 |
| Tank #1 | Storage | 2014 | 1,585 | \$ 3,519,755.00 | \$ 4,047,718.25 |
| Phase 5 - Water System Infrastructure | Distribution | 2015 | 2,219 | \$ 566,100.00 | \$ 667,998.00 |
| Phase 6 - Water System Infrastructure | Distribution | 2015 | 2,219 | \$ 221,187.50 | \$ 261,001.25 |
| Well #2 | Source | 2016 | 2,996 | \$ 475,650.00 | \$ 575,536.50 |
| Phase 7 - Water System Infrastructure | Distribution | 2016 | 2,996 | \$ 360,875.00 | \$ 436,658.75 |
| Tank #2 | Storage | 2018 | 4,681 | \$ 3,519,755.00 | \$ 4,470,088.85 |
| Well #3 | Source | 2019 | 5,617 | \$ 628,440.00 | \$ 816,972.00 |
| Tank #3 | Storage | 2021 | 7,589 | \$ 3,519,755.00 | \$ 4,786,866.80 |
| New Chlorination Bldg | Distribution | 2022 | 8,491 | \$ 187,500.00 | \$ 260,625.00 |
| Well #4 | Source | 2023 | 9,392 | \$ 628,440.00 | \$ 892,384.80 |
| Tank #4 | Storage | 2025 | 11,056 | \$ 3,837,255.00 | \$ 5,679,137.40 |
| Well #5 | Source | 2026 | 11,941 | \$ 475,650.00 | \$ 718,231.50 |
| Total | | | | \$24,345,068.75 | \$30,322,448.60 |

Existing Water System Infrastructure Valuation

It is beneficial, when setting impact fee requirements, to know the value of existing utility infrastructure. In the case of Pole Canyon, there is significant water system infrastructure particularly when storage is concerned. Table 11 below is a Water System Valuation. This valuation was prepared using estimated current day replacement costs of the individual components.

Table 11 – Existing Water System Valuation

| Item | Description | YR Operational | Design Life | Surplus Capacity (ERC) | Replacement Cost |
|------|------------------------|----------------|-------------|------------------------|---------------------|
| 1 | 220,000 Gal. Tank | 1979 | 50 | *296 | \$ 350,000 |
| 2 | 500,000 Gal. Tank | 1984 | 50 | *766 | \$ 750,000 |
| 3 | 1,000,000 Gal. Tank | 1979 | 65 | *1,408 | \$ 1,500,000 |
| 4 | Cook Well & Pump House | 1979 | 35 | 1,582 | \$ 300,000 |
| 5 | Booster Pump Station | 1979 | 35 | 1,582 | \$ 150,000 |
| 6 | Distribution Piping | 1979 | 65 | **1,845 | \$ 950,000 |
| | Totals | | | | \$ 4,000,000 |

*Storage was considered as one system with surplus capacity representing each tanks capacity as a ratio of total capacity.

**Distribution capacity is based on surplus capacity in the 10" Main line

Appendix

Estimate – Wells #1 & #2 & #5(2,000 gpm Each)

Estimate – Well #3 & #4 (3,000 gpm Each)

Estimate – Tank #1 (2 Million Gallon)

Estimate – Tank #2 (2 Million Gallon)

Estimate – Tank #3 (2 Million Gallon)

Estimate – Tank #4 (2 Million Gallon)

Estimate – Phase 1 – Water System Infrastructure

Estimate – Phase 2 – Water System Infrastructure

Estimate – Phase 3 – Water System Infrastructure

Estimate – Phase 4 – Water System Infrastructure

Estimate – Phase 5 – Water System Infrastructure

Estimate – Phase 6 – Water System Infrastructure

Estimate – Phase 7 – Water System Infrastructure

Estimate – Cook Well House Upgrade – Water System Infrastructure

Estimate – New Chlorination Building – Water System Infrastructure

WaterGEMS V8i Model Output

Pole Canyon
FUTURE UNDERGROUND WATER WELL (Wells 1 & 2 & 5) 2,000 gpm each

ENGINEER'S OPINION OF PROBABLE COSTS

DATE: **8/13/2008**

| Item | Description | Service Provider | Quantity | Unit | Unit Price | Amount |
|------|----------------------------------------------------------------------------------------------------------------------------|------------------|----------|--------|--------------|----------------------|
| 1 | Phase I - Obtain Authorization to Drill (Start Card) | | | | | |
| 2 | Water Rights - Change Application: This assumes that White Hills SSD has a completed detailed water rights summary. | AQUA | 10 | Hourly | \$ 85.00 | \$ 850.00 |
| 3 | Preliminary Well Location Assessment | AQUA / IGES | 1 | L.S. | \$ 2,000.00 | \$ 2,000.00 |
| 4 | PER (Preliminary Engineering Report) for State Approval | AQUA / IGES | 1 | L.S. | \$ 3,000.00 | \$ 3,000.00 |
| 5 | Engineering Design - Plans and Specifications for drilling and test pumping the new well for State Approval. | AQUA/IGES | 1 | L.S. | \$ 6,000.00 | \$ 6,000.00 |
| 6 | Phase I Total | | | | | \$ 11,850.00 |
| | Phase II - Drill, Equip, Connect to System | | | | | |
| 8 | Drill 18 " Well, install 16" Casing, Screens and Gravel Pack | Contractor (Bid) | 550 | Ln.Ft. | \$ 250.00 | \$ 137,500.00 |
| 10 | Test Pump | Contractor (Bid) | 1 | L.S. | \$ 30,000.00 | \$ 30,000.00 |
| 11 | Well House - Building, Valves, Electrical, Fencing | Contractor (Bid) | 1 | L.S. | \$100,000.00 | \$ 100,000.00 |
| 12 | New Pump, Motor, Tube, Shaft and Column | Contractor (Bid) | 1 | L.S. | \$100,000.00 | \$ 100,000.00 |
| 13 | Piping to Tank | Contractor (Bid) | 100 | Ln.Ft. | \$ 45.00 | \$ 4,500.00 |
| 14 | Construction Subtotal | | | | | \$ 372,000.00 |
| 15 | Contingency | | 15% | | | \$ 55,800.00 |
| 16 | Utility Power | TBD | | | | \$ 5,000.00 |
| 19 | Utilities and Land Subtotal | | | | | \$ 5,000.00 |
| 20 | Engineering Design - Well House, Pump, Elect, Etc. | AQUA | | Hourly | | \$ 12,500.00 |
| 21 | Bidding & Construction Management | AQUA | | Hourly | | \$ 10,000.00 |
| 22 | Engineering Subtotal | | | | | \$ 22,500.00 |
| 23 | Water Sampling | AQUA/Contractor | | L.S. | | \$ 3,500.00 |
| 25 | Revise Drinking Water Source Protection Plan | AQUA/IGES | | L.S. | | \$ 5,000.00 |
| 26 | Regulatory and Administration Subtotal | | | | | \$ 8,500.00 |
| 27 | Phase II Total | | | | | 463,800.00 |
| 28 | PROJECT TOTAL | | | | | 475,650.00 |

**Pole Canyon
FUTURE UNDERGROUND WATER WELL (Wells 3 & 4) 3,000 gpm each**

ENGINEER'S OPINION OF PROBABLE COSTS

DATE: **8/13/2008**

| Item | Description | Service Provider | Quantity | Unit | Unit Price | Amount |
|------|----------------------------------------------------------------------------------------------------------------------------|------------------|----------|--------|--------------|----------------------|
| 1 | Phase I - Obtain Authorization to Drill (Start Card) | | | | | |
| 2 | Water Rights - Change Application: This assumes that White Hills SSD has a completed detailed water rights summary. | AQUA | 10 | Hourly | \$ 85.00 | \$ 850.00 |
| 3 | Preliminary Well Location Assessment | AQUA / IGES | 1 | L.S. | \$ 2,000.00 | \$ 2,000.00 |
| 4 | PER (Preliminary Engineering Report) for State Approval | AQUA / IGES | 1 | L.S. | \$ 3,000.00 | \$ 3,000.00 |
| 5 | Engineering Design - Plans and Specifications for drilling and test pumping the new well for State Approval. | AQUA/IGES | 1 | L.S. | \$ 6,000.00 | \$ 6,000.00 |
| 6 | Phase I Total | | | | | \$ 11,850.00 |
| | Phase II - Drill, Equip, Connect to System | | | | | |
| 8 | Drill 24 " Well, install 20" Casing, Screens and Gravel Pack | Contractor (Bid) | 550 | Ln.Ft. | \$ 250.00 | \$ 137,500.00 |
| 10 | Test Pump | Contractor (Bid) | 1 | L.S. | \$ 50,000.00 | \$ 50,000.00 |
| 11 | Well House - Building, Valves, Electrical, Fencing | Contractor (Bid) | 1 | L.S. | \$150,000.00 | \$ 150,000.00 |
| 12 | New Pump, Motor, Tube, Shaft and Column | Contractor (Bid) | 1 | L.S. | \$125,000.00 | \$ 125,000.00 |
| 13 | Piping to Tank | Contractor (Bid) | 100 | Ln.Ft. | \$ 45.00 | \$ 4,500.00 |
| 14 | Construction Subtotal | | | | | \$ 467,000.00 |
| 15 | Contingency | | 15% | | | \$ 70,050.00 |
| 16 | Utility Power | TBD | | | | \$ 15,000.00 |
| 19 | Utilities and Land Subtotal | | | | | \$ 15,000.00 |
| 20 | Engineering Design - Well House, Pump, Elect, Etc. | AQUA | | Hourly | | \$ 32,690.00 |
| 21 | Bidding & Construction Management | AQUA | | Hourly | | \$ 23,350.00 |
| 22 | Engineering Subtotal | | | | | \$ 56,040.00 |
| 23 | Water Sampling | AQUA/Contractor | | L.S. | | \$ 3,500.00 |
| 25 | Revise Drinking Water Source Protection Plan | AQUA/IGES | | L.S. | | \$ 5,000.00 |
| 26 | Regulatory and Administration Subtotal | | | | | \$ 8,500.00 |
| 27 | Phase II Total | | | | | 616,590.00 |
| 28 | PROJECT TOTAL | | | | | 628,440.00 |

**Pole Canyon
2,000,000 GALLON STORAGE TANK #1**

ENGINEER'S OPINION OF PROBABLE COSTS

Revision: CGN DATE: 8/13/2008

| Item | Description | Service Provider | Quantity | Unit | Unit Price | Amount |
|------|--------------------------------------------|------------------|----------|--------|-----------------|------------------------|
| 1 | Tank Siting and Geotechnical Investigation | AQUA / IGES | 1 | L.S. | \$ 4,500.00 | \$ 4,500.00 |
| 2 | Mobilization | Contractor (Bid) | 1 | L.S. | \$ 75,000.00 | \$ 75,000.00 |
| 3 | Site Clearing and Grubbing | Contractor (Bid) | 1 | L.S. | \$ 18,000.00 | \$ 18,000.00 |
| 4 | Tank Excavation and Materials Disposal | Contractor (Bid) | 1 | L.S. | \$ 25,000.00 | \$ 25,000.00 |
| 5 | Tank Backfill | Contractor (Bid) | 1 | L.S. | \$ 18,000.00 | \$ 18,000.00 |
| 6 | Site Restoration and Landscaping | Contractor (Bid) | 1 | L.S. | \$ 25,000.00 | \$ 25,000.00 |
| 7 | Site Fencing | Contractor (Bid) | 1200 | L.F. | \$ 10.00 | \$ 12,000.00 |
| 8 | 1.0 M Gallon Concrete Tank Construction | Contractor (Bid) | 1 | L.S. | \$ 2,500,000.00 | \$ 2,500,000.00 |
| 9 | Tank and Tank Site Piping | Contractor (Bid) | 1 | L.S. | \$ 25,000.00 | \$ 25,000.00 |
| 10 | Connection to Distribution System | Contractor (Bid) | 1200 | L.F. | \$ 45.00 | \$ 54,000.00 |
| 11 | Construction Subtotal | | | | | \$ 2,756,500.00 |
| 12 | Contingency | | 15% | | | \$ 413,475.00 |
| 13 | Engineering Design | AQUA | | Hourly | | \$ 151,607.50 |
| 14 | Bidding & Construction Management | AQUA | | Hourly | | \$ 179,172.50 |
| 15 | Engineering Subtotal | | | | | \$ 330,780.00 |
| 16 | Rights-of-way | WHSSD/AQUA | | Hourly | | \$ 5,000.00 |
| 17 | Funding Administration | AQUA | | Hourly | | \$ 14,000.00 |
| 18 | Design and Administration Subtotal | | | | | \$ 19,000.00 |
| 19 | PROJECT TOTAL | | | | | 3,519,755.00 |

**Pole Canyon
2,000,000 GALLON STORAGE TANK #2**

ENGINEER'S OPINION OF PROBABLE COSTS

Revision: CGN DATE: 8/13/2008

| Item | Description | Service Provider | Quantity | Unit | Unit Price | Amount |
|------|--------------------------------------------|------------------|----------|--------|-----------------|------------------------|
| 1 | Tank Siting and Geotechnical Investigation | AQUA / IGES | 1 | L.S. | \$ 4,500.00 | \$ 4,500.00 |
| 2 | Mobilization | Contractor (Bid) | 1 | L.S. | \$ 75,000.00 | \$ 75,000.00 |
| 3 | Site Clearing and Grubbing | Contractor (Bid) | 1 | L.S. | \$ 18,000.00 | \$ 18,000.00 |
| 4 | Tank Excavation and Materials Disposal | Contractor (Bid) | 1 | L.S. | \$ 25,000.00 | \$ 25,000.00 |
| 5 | Tank Backfill | Contractor (Bid) | 1 | L.S. | \$ 18,000.00 | \$ 18,000.00 |
| 6 | Site Restoration and Landscaping | Contractor (Bid) | 1 | L.S. | \$ 25,000.00 | \$ 25,000.00 |
| 7 | Site Fencing | Contractor (Bid) | 1200 | L.F. | \$ 10.00 | \$ 12,000.00 |
| 8 | 1.0 M Gallon Concrete Tank Construction | Contractor (Bid) | 1 | L.S. | \$ 2,500,000.00 | \$ 2,500,000.00 |
| 9 | Tank and Tank Site Piping | Contractor (Bid) | 1 | L.S. | \$ 25,000.00 | \$ 25,000.00 |
| 10 | Connection to Distribution System | Contractor (Bid) | 1200 | L.F. | \$ 45.00 | \$ 54,000.00 |
| 11 | Construction Subtotal | | | | | \$ 2,756,500.00 |
| 12 | Contingency | | 15% | | | \$ 413,475.00 |
| 13 | Engineering Design | AQUA | | Hourly | | \$ 151,607.50 |
| 14 | Bidding & Construction Management | AQUA | | Hourly | | \$ 179,172.50 |
| 15 | Engineering Subtotal | | | | | \$ 330,780.00 |
| 16 | Rights-of-way | WHSSD/AQUA | | Hourly | | \$ 5,000.00 |
| 17 | Funding Administration | AQUA | | Hourly | | \$ 14,000.00 |
| 18 | Design and Administration Subtotal | | | | | \$ 19,000.00 |
| 19 | PROJECT TOTAL | | | | | 3,519,755.00 |

**Pole Canyon
2,000,000 GALLON STORAGE TANK #3**

ENGINEER'S OPINION OF PROBABLE COSTS

Revision: CGN DATE: 8/13/2008

| Item | Description | Service Provider | Quantity | Unit | Unit Price | Amount |
|------|--------------------------------------------|------------------|----------|--------|-----------------|------------------------|
| 1 | Tank Siting and Geotechnical Investigation | AQUA / IGES | 1 | L.S. | \$ 4,500.00 | \$ 4,500.00 |
| 2 | Mobilization | Contractor (Bid) | 1 | L.S. | \$ 75,000.00 | \$ 75,000.00 |
| 3 | Site Clearing and Grubbing | Contractor (Bid) | 1 | L.S. | \$ 18,000.00 | \$ 18,000.00 |
| 4 | Tank Excavation and Materials Disposal | Contractor (Bid) | 1 | L.S. | \$ 25,000.00 | \$ 25,000.00 |
| 5 | Tank Backfill | Contractor (Bid) | 1 | L.S. | \$ 18,000.00 | \$ 18,000.00 |
| 6 | Site Restoration and Landscaping | Contractor (Bid) | 1 | L.S. | \$ 25,000.00 | \$ 25,000.00 |
| 7 | Site Fencing | Contractor (Bid) | 1200 | L.F. | \$ 10.00 | \$ 12,000.00 |
| 8 | 1.0 M Gallon Concrete Tank Construction | Contractor (Bid) | 1 | L.S. | \$ 2,500,000.00 | \$ 2,500,000.00 |
| 9 | Tank and Tank Site Piping | Contractor (Bid) | 1 | L.S. | \$ 25,000.00 | \$ 25,000.00 |
| 10 | Connection to Distribution System | Contractor (Bid) | 1200 | L.F. | \$ 45.00 | \$ 54,000.00 |
| 11 | Construction Subtotal | | | | | \$ 2,756,500.00 |
| 12 | Contingency | | 15% | | | \$ 413,475.00 |
| 13 | Engineering Design | AQUA | | Hourly | | \$ 151,607.50 |
| 14 | Bidding & Construction Management | AQUA | | Hourly | | \$ 179,172.50 |
| 15 | Engineering Subtotal | | | | | \$ 330,780.00 |
| 16 | Rights-of-way | WHSSD/AQUA | | Hourly | | \$ 5,000.00 |
| 17 | Funding Administration | AQUA | | Hourly | | \$ 14,000.00 |
| 18 | Design and Administration Subtotal | | | | | \$ 19,000.00 |
| 19 | PROJECT TOTAL | | | | | 3,519,755.00 |

**Pole Canyon
2,200,000 GALLON STORAGE TANK #4**

ENGINEER'S OPINION OF PROBABLE COSTS

Revision: CGN DATE: 8/13/2008

| Item | Description | Service Provider | Quantity | Unit | Unit Price | Amount |
|------|--------------------------------------------|------------------|----------|--------|-----------------|------------------------|
| 1 | Tank Siting and Geotechnical Investigation | AQUA / IGES | 1 | L.S. | \$ 4,500.00 | \$ 4,500.00 |
| 2 | Mobilization | Contractor (Bid) | 1 | L.S. | \$ 75,000.00 | \$ 75,000.00 |
| 3 | Site Clearing and Grubbing | Contractor (Bid) | 1 | L.S. | \$ 18,000.00 | \$ 18,000.00 |
| 4 | Tank Excavation and Materials Disposal | Contractor (Bid) | 1 | L.S. | \$ 25,000.00 | \$ 25,000.00 |
| 5 | Tank Backfill | Contractor (Bid) | 1 | L.S. | \$ 18,000.00 | \$ 18,000.00 |
| 6 | Site Restoration and Landscaping | Contractor (Bid) | 1 | L.S. | \$ 25,000.00 | \$ 25,000.00 |
| 7 | Site Fencing | Contractor (Bid) | 1200 | L.F. | \$ 10.00 | \$ 12,000.00 |
| 8 | 1.0 M Gallon Concrete Tank Construction | Contractor (Bid) | 1 | L.S. | \$ 2,750,000.00 | \$ 2,750,000.00 |
| 9 | Tank and Tank Site Piping | Contractor (Bid) | 1 | L.S. | \$ 25,000.00 | \$ 25,000.00 |
| 10 | Connection to Distribution System | Contractor (Bid) | 1200 | L.F. | \$ 45.00 | \$ 54,000.00 |
| 11 | Construction Subtotal | | | | | \$ 3,006,500.00 |
| 12 | Contingency | | 15% | | | \$ 450,975.00 |
| 13 | Engineering Design | AQUA | | Hourly | | \$ 165,357.50 |
| 14 | Bidding & Construction Management | AQUA | | Hourly | | \$ 195,422.50 |
| 15 | Engineering Subtotal | | | | | \$ 360,780.00 |
| 16 | Rights-of-way | WHSSD/AQUA | | Hourly | | \$ 5,000.00 |
| 17 | Funding Administration | AQUA | | Hourly | | \$ 14,000.00 |
| 18 | Design and Administration Subtotal | | | | | \$ 19,000.00 |
| 19 | PROJECT TOTAL | | | | | 3,837,255.00 |

**Pole Canyon
Phase 1 - Water System Infrastructure**

ENGINEER'S OPINION OF PROBABLE COSTS

DATE: **9/9/2008**

| Item | Description | Service Provider | Quantity | Unit | Unit Price | Amount |
|------|-----------------------------------|------------------|----------|--------|--------------|------------------------|
| 1 | Mobilization | Contractor (Bid) | 1 | L.S. | \$ 15,000.00 | \$ 15,000.00 |
| 2 | 12" Ductile Iron Pipe | Contractor (Bid) | 5000 | L.F. | \$ 40.00 | \$ 200,000.00 |
| 3 | 14" Ductile Iron Pipe | Contractor (Bid) | 2000 | L.F. | \$ 45.00 | \$ 90,000.00 |
| 4 | 18" Ductile Iron Pipe | Contractor (Bid) | 1100 | L.F. | \$ 55.00 | \$ 60,500.00 |
| 5 | 24" Ductile Iron Pipe | Contractor (Bid) | 4300 | L.F. | \$ 65.00 | \$ 279,500.00 |
| 6 | 30" Ductile Iron Pipe | Contractor (Bid) | 1400 | L.F. | \$ 70.00 | \$ 98,000.00 |
| 7 | Reconnect Existing 10" Line | Contractor (Bid) | 2 | E.A. | \$ 3,000.00 | \$ 6,000.00 |
| 8 | Fire Hydrants | Contractor (Bid) | 29 | E.A. | \$ 4,500.00 | \$ 130,500.00 |
| 9 | PRV Station | Contractor (Bid) | 4 | L.S. | \$ 55,000.00 | \$ 220,000.00 |
| 10 | Highway 73 Crossing | Contractor (Bid) | 1 | L.S. | \$ 10,000.00 | \$ 10,000.00 |
| 11 | Lower tank Bypass | Contractor (Bid) | 1 | L.S. | \$ 50,000.00 | \$ 50,000.00 |
| | Construction Subtotal | | | | | \$ 1,159,500.00 |
| 12 | Contingency | | 15% | | | \$ 173,900.00 |
| 13 | Engineering Design | AQUA | | Hourly | | \$ 86,962.50 |
| 14 | Bidding & Construction Management | AQUA | | Hourly | | \$ 57,975.00 |
| 15 | Engineering Subtotal | | | | | \$ 144,937.50 |
| | PROJECT TOTAL | | | | | 1,478,337.50 |



**Pole Canyon
Phase 2 - Water System Infrastructure**

ENGINEER'S OPINION OF PROBABLE COSTS

DATE: 9/9/2008

| Item | Description | Service Provider | Quantity | Unit | Unit Price | Amount |
|------------------------------|-------------------------------------------|------------------|----------|--------|---------------|------------------------|
| 1 | Mobilization | Contractor (Bid) | 1 | L.S. | \$ 10,000.00 | \$ 10,000.00 |
| 2 | 8" PVC Pipe | Contractor (Bid) | 8700 | L.F. | \$ 30.00 | \$ 261,000.00 |
| 3 | 24" Ductile Iron Pipe | Contractor (Bid) | 1800 | L.F. | \$ 65.00 | \$ 117,000.00 |
| 4 | 30" Ductile Iron Pipe | Contractor (Bid) | 12300 | L.F. | \$ 70.00 | \$ 861,000.00 |
| 5 | 36" Ductile Iron Pipe | Contractor (Bid) | 2000 | L.F. | \$ 75.00 | \$ 150,000.00 |
| 6 | Fire Hydrants | Contractor (Bid) | 40 | E.A. | \$ 4,500.00 | \$ 180,000.00 |
| 7 | PRV Station | Contractor (Bid) | 3 | L.S. | \$ 55,000.00 | \$ 165,000.00 |
| 8 | 24" Ductile Iron Pipe - From Pump Station | Contractor (Bid) | 5000 | L.F. | \$ 65.00 | \$ 325,000.00 |
| 9 | Pump Station | Contractor (Bid) | 1 | L.S. | \$ 500,000.00 | \$ 500,000.00 |
| Construction Subtotal | | | | | | \$ 2,569,000.00 |
| 10 | Contingency | | 15% | | | \$ 261,600.00 |
| 11 | Engineering Design | AQUA | | Hourly | | \$ 192,675.00 |
| 12 | Bidding & Construction Management | AQUA | | Hourly | | \$ 128,450.00 |
| 13 | Engineering Subtotal | | | | | \$ 321,125.00 |
| PROJECT TOTAL | | | | | | 3,151,725.00 |



**Pole Canyon
Phase 3 - Water System Infrastructure**

ENGINEER'S OPINION OF PROBABLE COSTS

DATE: **9/9/2008**

| Item | Description | Service Provider | Quantity | Unit | Unit Price | Amount |
|------|-----------------------------------|------------------|----------|--------|--------------|----------------------|
| 1 | Mobilization | Contractor (Bid) | 1 | L.S. | \$ 10,000.00 | \$ 10,000.00 |
| 2 | 10" Ductile Iron Pipe | Contractor (Bid) | 2000 | L.F. | \$ 35.00 | \$ 70,000.00 |
| 3 | 14" Ductile Iron Pipe | Contractor (Bid) | 3100 | L.F. | \$ 45.00 | \$ 139,500.00 |
| 4 | Fire Hydrants | Contractor (Bid) | 11 | E.A. | \$ 4,500.00 | \$ 49,500.00 |
| 5 | PRV Station | Contractor (Bid) | 1 | L.S. | \$ 55,000.00 | \$ 55,000.00 |
| | Construction Subtotal | | | | | \$ 324,000.00 |
| 6 | Contingency | | 15% | | | \$ 48,600.00 |
| 7 | Engineering Design | AQUA | | Hourly | | \$ 24,300.00 |
| 8 | Bidding & Construction Management | AQUA | | Hourly | | \$ 16,200.00 |
| 9 | Engineering Subtotal | | | | | \$ 40,500.00 |
| | PROJECT TOTAL | | | | | 413,100.00 |



**Pole Canyon
Phase 4 - Water System Infrastructure**

ENGINEER'S OPINION OF PROBABLE COSTS

DATE: **9/9/2008**

| Item | Description | Service Provider | Quantity | Unit | Unit Price | Amount |
|------------------------------|-----------------------------------|------------------|----------|--------|--------------|----------------------|
| 1 | Mobilization | Contractor (Bid) | 1 | L.S. | \$ 10,000.00 | \$ 10,000.00 |
| 2 | 8" PVC Pipe | Contractor (Bid) | 2200 | L.F. | \$ 30.00 | \$ 66,000.00 |
| 3 | 12" Ductile Iron Pipe | Contractor (Bid) | 4300 | L.F. | \$ 40.00 | \$ 172,000.00 |
| 4 | 14" Cuctile Iron Pipe | Contractor (Bid) | 5800 | L.F. | \$ 45.00 | \$ 261,000.00 |
| 5 | Fire Hydrants | Contractor (Bid) | 22 | E.A. | \$ 4,500.00 | \$ 99,000.00 |
| 6 | PRV Station | Contractor (Bid) | 1 | L.S. | \$ 55,000.00 | \$ 55,000.00 |
| Construction Subtotal | | | | | | \$ 663,000.00 |
| 7 | Contingency | | 15% | | | \$ 99,500.00 |
| 8 | Engineering Design | AQUA | | Hourly | | \$ 49,725.00 |
| 9 | Bidding & Construction Management | AQUA | | Hourly | | \$ 33,150.00 |
| 10 | Engineering Subtotal | | | | | \$ 82,875.00 |
| PROJECT TOTAL | | | | | | 845,375.00 |



**Pole Canyon
Phase 5 - Water System Infrastructure**

ENGINEER'S OPINION OF PROBABLE COSTS

DATE: **9/9/2008**

| Item | Description | Service Provider | Quantity | Unit | Unit Price | Amount |
|------------------------------|-----------------------------------|------------------|----------|--------|--------------|----------------------|
| 1 | Mobilization | Contractor (Bid) | 1 | L.S. | \$ 10,000.00 | \$ 10,000.00 |
| 2 | 8" PVC Pipe | Contractor (Bid) | 4200 | L.F. | \$ 30.00 | \$ 126,000.00 |
| 3 | 10" PVC Pipe | Contractor (Bid) | 2500 | L.F. | \$ 35.00 | \$ 87,500.00 |
| 4 | 14" Ductile Iron Pipe | Contractor (Bid) | 2100 | L.F. | \$ 45.00 | \$ 94,500.00 |
| 5 | Fire Hydrants | Contractor (Bid) | 28 | E.A. | \$ 4,500.00 | \$ 126,000.00 |
| 6 | PRV Station | Contractor (Bid) | 0 | L.S. | \$ 55,000.00 | \$ - |
| Construction Subtotal | | | | | | \$ 444,000.00 |
| 7 | Contingency | | 15% | | | \$ 66,600.00 |
| 8 | Engineering Design | AQUA | | Hourly | | \$ 33,300.00 |
| 9 | Bidding & Construction Management | AQUA | | Hourly | | \$ 22,200.00 |
| 10 | Engineering Subtotal | | | | | \$ 55,500.00 |
| PROJECT TOTAL | | | | | | 566,100.00 |



**Pole Canyon
Phase 6 - Water System Infrastructure**

ENGINEER'S OPINION OF PROBABLE COSTS

DATE: 9/9/2008

| Item | Description | Service Provider | Quantity | Unit | Unit Price | Amount |
|------------------------------|-----------------------------------|------------------|----------|--------|--------------|----------------------|
| 1 | Mobilization | Contractor (Bid) | 1 | L.S. | \$ 10,000.00 | \$ 10,000.00 |
| 2 | 10" PVC Pipe | Contractor (Bid) | 2100 | L.F. | \$ 35.00 | \$ 73,500.00 |
| 3 | Fire Hydrants | Contractor (Bid) | 20 | E.A. | \$ 4,500.00 | \$ 90,000.00 |
| 4 | PRV Station | Contractor (Bid) | 0 | L.S. | \$ 55,000.00 | \$ - |
| Construction Subtotal | | | | | | \$ 173,500.00 |
| 5 | Contingency | | 15% | | | \$ 26,000.00 |
| 6 | Engineering Design | AQUA | | Hourly | | \$ 13,012.50 |
| 7 | Bidding & Construction Management | AQUA | | Hourly | | \$ 8,675.00 |
| 8 | Engineering Subtotal | | | | | \$ 21,687.50 |
| PROJECT TOTAL | | | | | | 221,187.50 |



**Pole Canyon
Phase 7 - Water System Infrastructure**

ENGINEER'S OPINION OF PROBABLE COSTS

DATE: **9/9/2008**

| Item | Description | Service Provider | Quantity | Unit | Unit Price | Amount |
|------|-----------------------------------|------------------|----------|--------|--------------|----------------------|
| 1 | Mobilization | Contractor (Bid) | 1 | L.S. | \$ 10,000.00 | \$ 10,000.00 |
| 2 | 8" PVC Pipe | Contractor (Bid) | 4200 | L.F. | \$ 30.00 | \$ 126,000.00 |
| 3 | 10" PVC Pipe | Contractor (Bid) | 1500 | L.F. | \$ 35.00 | \$ 52,500.00 |
| 4 | Fire Hydrants | Contractor (Bid) | 21 | E.A. | \$ 4,500.00 | \$ 94,500.00 |
| 5 | PRV Station | Contractor (Bid) | 0 | L.S. | \$ 55,000.00 | \$ - |
| | Construction Subtotal | | | | | \$ 283,000.00 |
| 6 | Contingency | | 15% | | | \$ 42,500.00 |
| 7 | Engineering Design | AQUA | | Hourly | | \$ 21,225.00 |
| 8 | Bidding & Construction Management | AQUA | | Hourly | | \$ 14,150.00 |
| 9 | Engineering Subtotal | | | | | \$ 35,375.00 |
| | PROJECT TOTAL | | | | | 360,875.00 |

**Pole Canyon - White Hills SSD
Cook Well House Upgrade**

ENGINEER'S OPINION OF PROBABLE COSTS

DATE: 8/26/2009

Phase 1

| Item | Description | Service Provider | Quantity | Unit | Unit Price | Amount |
|------|---------------------------------------------------|------------------|----------|------|--------------|---------------------|
| 1 | Building Upgrade | | | | | |
| | Roof Demolition | Contractor (Bid) | 1 | L.S. | \$ 1,500.00 | \$ 1,500.00 |
| | Frame and Cover - pitched metal roof 12" overhang | Contractor (Bid) | 1 | L.S. | \$ 2,000.00 | \$ 2,000.00 |
| | New Soffit and Facia | Contractor (Bid) | 1 | L.S. | \$ 750.00 | \$ 750.00 |
| | Replace door | Contractor (Bid) | 1 | L.S. | \$ 500.00 | \$ 500.00 |
| | Upgrade Heat and a/c | Contractor (Bid) | 1 | L.S. | \$ 5,000.00 | \$ 5,000.00 |
| | Stucco Exterior | Contractor (Bid) | 1 | L.S. | \$ 2,000.00 | \$ 2,000.00 |
| 2 | Controls, Electrical & Telemetry Equipment | Contractor (Bid) | 1 | L.S. | \$ 20,000.00 | \$ 20,000.00 |
| 3 | Construction Subtotal | | | | | \$ 31,750.00 |
| 4 | Contingency | | 15% | | | \$ 4,800.00 |
| 5 | Bidding & Construction Management | AQUA | | | | \$ 3,500.00 |
| 6 | PHASE 1 TOTAL | | | | | 40,050.00 |

Phase 2 *

| Item | Description | Service Provider | Quantity | Unit | Unit Price | Amount |
|------|----------------------------------------|------------------|----------|------|--------------|------------------|
| 1 | Chlorine Disinfection Injection System | | | | | |
| | Equipment | Contractor (Bid) | 1 | L.S. | \$ 12,000.00 | \$ 12,000.00 |
| | Installation | Contractor (Bid) | 1 | L.S. | \$ 1,500.00 | \$ 1,500.00 |
| | Calibration & Start-up | Contractor (Bid) | 1 | L.S. | \$ 1,500.00 | \$ 1,500.00 |
| 2 | PHASE 2 TOTAL | | | | | 15,000.00 |
| 3 | PROJECT TOTAL | | | | | 55,050.00 |

* A chlorine disinfection injection system will also need to be added to the system when the physical connection of the White Hills Subdivision system is made with the Eagle Mountain culinary system or if the source fails biological testing.



**Pole Canyon
New Chlorination Building - Water System Infrastructure**

ENGINEER'S OPINION OF PROBABLE COSTS

DATE: **9/9/2008**

| Item | Description | Service Provider | Quantity | Unit | Unit Price | Amount |
|------------------------------|-----------------------------------|------------------|----------|--------|---------------|----------------------|
| 1 | New Chlorination Building | Contractor (Bid) | 1 | L.S. | \$ 150,000.00 | \$ 150,000.00 |
| Construction Subtotal | | | | | | \$ 150,000.00 |
| 3 | Contingency | | 10% | | | \$ 22,500.00 |
| 4 | Engineering Design | AQUA | | Hourly | | \$ 7,500.00 |
| 5 | Bidding & Construction Management | AQUA | | Hourly | | \$ 7,500.00 |
| 6 | Engineering Subtotal | | | | | \$ 15,000.00 |
| PROJECT TOTAL | | | | | | 187,500.00 |

JUNCTION INFORMATION FOR FUTURE PEAK HOUR USE

| Label | Demand (gpm) | Elevation (ft) | Calculated Hydraulic Grade (ft) | Pressure (psi) | Comments |
|-------|--------------|----------------|---------------------------------|----------------|----------|
| J-3 | 407.51 | 4984.0 | 5158.5 | 75.5 | |
| J-4 | 335.7 | 4998.0 | 5159.3 | 69.8 | |
| J-5 | 33.44 | 5001.0 | 5159.9 | 68.8 | |
| J-6 | 33.44 | 5025.0 | 5161.5 | 59.1 | |
| J-7 | 8.75 | 5050.0 | 5167.8 | 51.0 | |
| J-8 | 8.75 | 5064.0 | 5168.2 | 45.1 | |
| J-10 | 8.75 | 5082.0 | 5168.2 | 37.3 | |
| J-11 | 8.75 | 5052.0 | 5169.0 | 50.6 | |
| J-12 | 8.75 | 5052.0 | 5170.3 | 51.2 | |
| J-13 | 8.75 | 5050.0 | 5172.4 | 52.9 | |
| J-14 | 8.75 | 5060.0 | 5173.1 | 48.9 | |
| J-15 | 8.75 | 5071.0 | 5173.5 | 44.3 | |
| J-16 | 8.75 | 5079.0 | 5174.2 | 41.2 | |
| J-17 | 8.75 | 5095.0 | 5175.7 | 34.9 | |
| J-18 | 8.75 | 5087.0 | 5173.0 | 37.2 | |
| J-19 | 8.75 | 5073.0 | 5173.1 | 43.3 | |
| J-20 | 8.75 | 5062.0 | 5173.0 | 48.0 | |
| J-21 | 8.75 | 5078.0 | 5170.5 | 40.0 | |
| J-22 | 12.79 | 5091.0 | 5284.6 | 83.8 | |
| J-24 | 8.75 | 5041.0 | 5170.3 | 55.9 | |
| J-25 | 8.75 | 5034.0 | 5169.0 | 58.4 | |
| J-26 | 8.75 | 5071.0 | 5169.1 | 42.4 | |
| J-27 | 0 | 5166.0 | 5195.1 | 12.6 | |
| J-30 | 0 | 5187.0 | 5436.9 | 108.1 | |
| J-33 | 0 | 5202.0 | 5437.6 | 101.9 | |
| J-34 | 0 | 5218.0 | 5437.5 | 95.0 | |
| J-35 | 0 | 5207.0 | 5437.2 | 99.6 | |
| J-40 | 0 | 5170.0 | 5436.6 | 115.4 | |
| J-59 | 0 | 4991.5 | 5160.2 | 73.0 | |
| J-60 | 0 | 4952.0 | 5160.2 | 90.1 | |
| J-61 | 288.35 | 5012.3 | 5160.2 | 64.0 | |
| J-62 | 1,132.10 | 5026.2 | 5162.9 | 59.2 | |
| J-63 | 565.26 | 5021.3 | 5150.8 | 56.0 | |
| J-64 | 565.26 | 4996.5 | 5124.3 | 55.3 | |
| J-65 | 1,190.67 | 4922.5 | 5044.7 | 52.9 | |
| J-67 | 478.87 | 5118.6 | 5285.2 | 72.1 | |
| J-69 | 284.31 | 4889.0 | 5028.6 | 60.4 | |
| J-70 | 1,693.77 | 4872.0 | 5016.3 | 62.4 | |
| J-73 | 658.84 | 4878.0 | 5036.0 | 68.4 | |
| J-74 | 335.7 | 4970.0 | 5157.1 | 81.0 | |
| J-75 | 335.7 | 4922.0 | 5051.5 | 56.0 | |
| J-76 | 1,476.10 | 4888.0 | 5039.8 | 65.7 | |
| J-78 | 1,046.15 | 5116.1 | 5285.5 | 73.3 | |
| J-79 | 415.81 | 5101.5 | 5277.6 | 76.2 | |

JUNCTION INFORMATION FOR FUTURE PEAK HOUR USE

| | | | | | |
|-------|----------|--------|--------|-------|--|
| J-80 | 462.94 | 5263.0 | 5440.4 | 76.7 | |
| J-81 | 0 | 5166.0 | 5436.6 | 117.1 | |
| J-82 | 291.27 | 5119.4 | 5284.6 | 71.5 | |
| J-83 | 658.84 | 4879.0 | 5030.3 | 65.5 | |
| J-84 | 773.06 | 4880.0 | 5013.1 | 57.6 | |
| J-85 | 0 | 5170.0 | 5436.6 | 115.4 | |
| J-87 | 749.05 | 4872.0 | 5007.4 | 58.6 | |
| J-89 | 896.48 | 4876.0 | 4998.8 | 53.1 | |
| J-90 | 8.75 | 5072.0 | 5168.2 | 41.6 | |
| J-91 | 327.18 | 5059.0 | 5283.8 | 97.2 | |
| J-93 | 0 | 5207.5 | 5437.8 | 99.6 | |
| J-94 | 217.44 | 5232.0 | 5436.6 | 88.5 | |
| J-95 | 773.06 | 4885.0 | 5004.9 | 51.9 | |
| J-97 | 749.05 | 4863.0 | 5009.9 | 63.5 | |
| J-103 | 182.21 | 4871.0 | 5023.7 | 66.1 | |
| J-104 | 105.47 | 5207.5 | 5437.6 | 99.5 | |
| J-105 | 12.79 | 5097.0 | 5284.6 | 81.2 | |
| J-107 | 105.47 | 5218.0 | 5437.4 | 94.9 | |
| J-108 | 217.44 | 5240.0 | 5430.4 | 82.4 | |
| J-112 | 1,253.05 | 4870.0 | 5018.9 | 64.4 | |
| J-113 | 896.48 | 4880.0 | 4998.7 | 51.3 | |
| J-115 | 0 | 5395.0 | 5442.6 | 20.6 | |

PIPE INFORMATION FOR FUTURE PEAK HOUR USE

| Label | Start Node | Stop Node | Diameter (in) | Scaled Length (ft) | Flow (gpm) | Headloss (Friction) (ft) | Velocity (Maximum) (ft/s) |
|-------|------------|------------|---------------|--------------------|------------|--------------------------|---------------------------|
| P-3 | 82: J-3 | 83: J-4 | 10 | 780 | -361.82 | 0.73 | 1.48 |
| P-4 | 83: J-4 | 84: J-5 | 10 | 208 | -697.52 | 0.66 | 2.85 |
| P-5 | 84: J-5 | 85: J-6 | 10 | 472 | -730.96 | 1.63 | 2.99 |
| P-9 | 118: J-90 | 88: J-10 | 10 | 322 | 8.75 | 0.00 | 0.04 |
| P-10 | 86: J-7 | 89: J-11 | 10 | 250 | -888.39 | 1.24 | 3.63 |
| P-11 | 89: J-11 | 90: J-12 | 10 | 288 | -837.49 | 1.28 | 3.42 |
| P-12 | 90: J-12 | 91: J-13 | 10 | 588 | -738.51 | 2.07 | 3.02 |
| P-13 | 91: J-13 | 92: J-14 | 10 | 575 | -427.58 | 0.73 | 1.75 |
| P-14 | 92: J-14 | 93: J-15 | 10 | 287 | -436.33 | 0.38 | 1.78 |
| P-15 | 93: J-15 | 94: J-16 | 10 | 277 | -635.14 | 0.74 | 2.59 |
| P-16 | 94: J-16 | 95: J-17 | 10 | 275 | -938.38 | 1.51 | 3.83 |
| P-17 | 95: J-17 | 96: J-18 | 8 | 575 | 484.26 | 2.74 | 3.09 |
| P-20 | 97: J-19 | 96: J-18 | 8 | 275 | 147.36 | 0.15 | 0.94 |
| P-21 | 94: J-16 | 97: J-19 | 8 | 575 | 294.48 | 1.09 | 1.88 |
| P-22 | 91: J-13 | 98: J-20 | 8 | 285 | -319.68 | 0.63 | 2.04 |
| P-23 | 98: J-20 | 97: J-19 | 8 | 277 | -138.37 | 0.13 | 0.88 |
| P-24 | 93: J-15 | 98: J-20 | 8 | 575 | 190.06 | 0.48 | 1.21 |
| P-25 | 96: J-18 | 99: J-21 | 8 | 324 | 622.87 | 2.46 | 3.98 |
| P-27 | 90: J-12 | 99: J-21 | 8 | 641 | -116.48 | 0.22 | 0.74 |
| P-29 | 100: J-22 | 155: J-105 | 12 | 170 | -12.79 | 0.00 | 0.04 |
| P-30 | 90: J-12 | 101: J-24 | 8 | 244 | 8.75 | 0.00 | 0.06 |
| P-31 | 102: J-25 | 89: J-11 | 8 | 408 | -8.75 | 0.00 | 0.06 |
| P-32 | 99: J-21 | 103: J-26 | 8 | 286 | 497.63 | 1.43 | 3.18 |
| P-33 | 103: J-26 | 87: J-8 | 8 | 251 | 420.47 | 0.92 | 2.68 |
| P-34 | 89: J-11 | 103: J-26 | 8 | 483 | -68.40 | 0.06 | 0.44 |
| P-41 | 130: J-34 | 137: J-33 | 10 | 332 | -217.44 | 0.12 | 13.30 |
| P-42 | 135: J-30 | 133: J-35 | 10 | 679 | -217.44 | 0.25 | 13.30 |
| P-43 | 133: J-35 | 130: J-34 | 10 | 792 | -217.44 | 0.29 | 13.30 |
| P-49 | 136: J-85 | 134: J-40 | 10 | 133 | 0.00 | 0.00 | 12.41 |
| P-50 | 134: J-40 | 131: J-81 | 10 | 142 | 0.00 | 0.00 | 12.41 |
| P-87 | 104: J-69 | 105: J-70 | 12 | 2,203 | 1532.22 | 12.31 | 4.35 |
| P-93 | 110: J-75 | 111: J-76 | 24 | 2,210 | 9227.76 | 11.73 | 6.54 |
| P-94 | 111: J-76 | 108: J-73 | 24 | 991 | 7751.66 | 3.81 | 5.50 |
| P-121 | 138: J-59 | 139: J-60 | 10 | 2,420 | 0.00 | 0.00 | 0.00 |
| P-122 | 140: J-61 | 138: J-59 | 10 | 776 | 0.00 | 0.00 | 0.00 |
| P-123 | 82: J-3 | 140: J-61 | 30 | 806 | -9944.86 | 1.66 | 4.51 |
| P-124 | 112: J-83 | 108: J-73 | 18 | 1,120 | -4238.78 | 5.72 | 5.34 |
| P-125 | 112: J-83 | 113: J-84 | 14 | 2,017 | 2882.58 | 17.14 | 6.01 |
| P-131 | 117: J-89 | 113: J-84 | 8 | 2,426 | -544.14 | 14.36 | 3.47 |
| P-132 | 157: T-2 | 131: J-81 | 10 | 54 | 0.00 | 0.00 | 12.41 |
| P-133 | 140: J-61 | 141: J-62 | 30 | 1,392 | -9723.75 | 2.75 | 4.41 |
| P-134 | 141: J-62 | 142: J-63 | 10 | 1,994 | 993.00 | 12.12 | 4.06 |
| P-135 | 142: J-63 | 143: J-64 | 14 | 2,100 | 3572.46 | 26.55 | 7.45 |
| P-137 | 144: J-65 | 104: J-69 | 12 | 2,101 | 1816.53 | 16.09 | 5.15 |

PIPE INFORMATION FOR FUTURE PEAK HOUR USE

| | | | | | | | |
|-------|-------------|-------------|----|-------|-----------|-------|-------|
| P-144 | 146: J-67 | 149: J-78 | 8 | 3,844 | -59.40 | 0.38 | 0.38 |
| P-145 | 149: J-78 | 150: J-79 | 8 | 2,193 | 415.81 | 7.89 | 2.65 |
| P-146 | 146: J-67 | 151: J-82 | 12 | 460 | 644.03 | 0.52 | 1.83 |
| P-147 | 151: J-82 | 152: J-91 | 12 | 2,760 | 327.18 | 0.88 | 0.93 |
| P-149 | 128: J-94 | 135: J-30 | 10 | 818 | -217.44 | 0.30 | 13.30 |
| P-152 | 137: J-33 | 153: J-93 | 10 | 479 | -217.44 | 0.17 | 13.30 |
| P-153 | 136: J-85 | 128: J-94 | 10 | 1,051 | 0.00 | 0.00 | 12.41 |
| P-154 | 153: J-93 | 132: J-80 | 36 | 995 | -18224.23 | 2.58 | 6.70 |
| P-158 | 153: J-93 | 154: J-104 | 24 | 130 | 4771.56 | 0.20 | 3.38 |
| P-159 | 87: J-8 | 118: J-90 | 10 | 276 | 17.50 | 0.00 | 0.07 |
| P-160 | 87: J-8 | 86: J-7 | 10 | 343 | 394.22 | 0.38 | 1.61 |
| P-161 | 154: J-104 | 159: PRV-10 | 24 | 403 | 4666.09 | 0.60 | 3.31 |
| P-162 | 159: PRV-10 | 149: J-78 | 24 | 1,354 | 4666.09 | 2.03 | 3.31 |
| P-163 | 82: J-3 | 109: J-74 | 30 | 683 | 9899.17 | 1.39 | 4.49 |
| P-165 | 109: J-74 | 158: PRV-16 | 30 | 705 | 9563.46 | 1.35 | 4.34 |
| P-166 | 158: PRV-16 | 110: J-75 | 24 | 1,063 | 9563.46 | 6.03 | 6.78 |
| P-168 | 149: J-78 | 160: PRV-12 | 14 | 1,576 | 3144.73 | 15.74 | 6.55 |
| P-169 | 160: PRV-12 | 142: J-63 | 14 | 1,479 | 3144.73 | 14.77 | 6.55 |
| P-170 | 141: J-62 | 161: PRV-13 | 30 | 929 | -11848.85 | 2.64 | 5.38 |
| P-171 | 113: J-84 | 119: J-95 | 12 | 1,423 | 1565.38 | 8.27 | 4.44 |
| P-173 | 161: PRV-13 | 146: J-67 | 30 | 1,514 | -11848.85 | 4.31 | 5.38 |
| P-174 | 143: J-64 | 162: PRV-14 | 14 | 2,236 | 3007.20 | 20.55 | 6.27 |
| P-182 | 108: J-73 | 127: J-103 | 14 | 1,474 | 2854.04 | 12.30 | 5.95 |
| P-184 | 162: PRV-14 | 144: J-65 | 14 | 1,404 | 3007.20 | 12.90 | 6.27 |
| P-185 | 151: J-82 | 155: J-105 | 12 | 591 | 25.58 | 0.00 | 0.07 |
| P-187 | 86: J-7 | 85: J-6 | 10 | 648 | 1273.86 | 6.25 | 5.20 |
| P-192 | 129: J-27 | 95: J-17 | 10 | 1,614 | 1431.39 | 19.32 | 5.85 |
| P-196 | 140: J-61 | 85: J-6 | 10 | 769 | -509.46 | 1.36 | 2.08 |
| P-197 | 100: J-22 | 272: PRV-20 | 12 | 225 | 0.00 | 0.00 | 0.00 |
| P-198 | 272: PRV-20 | 99: J-21 | 12 | 53 | 0.00 | 0.00 | 0.00 |
| P-199 | 157: T-2 | 129: J-27 | 10 | 79 | 1431.39 | 0.95 | 5.85 |
| P-200 | 153: J-93 | 290: J-107 | 30 | 102 | 13235.23 | 0.36 | 6.01 |
| P-203 | 290: J-107 | 292: J-108 | 30 | 2,040 | 13129.77 | 7.02 | 5.96 |
| P-205 | 292: J-108 | 302: PRV-24 | 30 | 1,859 | 12912.32 | 6.20 | 5.86 |
| P-206 | 302: PRV-24 | 146: J-67 | 30 | 715 | 12912.35 | 2.38 | 5.86 |
| P-207 | 127: J-103 | 305: J-112 | 14 | 654 | 2671.82 | 4.83 | 5.57 |
| P-208 | 305: J-112 | 121: J-97 | 10 | 2,497 | 749.05 | 9.01 | 3.06 |
| P-209 | 305: J-112 | 115: J-87 | 8 | 2,207 | 508.17 | 11.51 | 3.24 |
| P-210 | 119: J-95 | 309: J-113 | 10 | 2,017 | 792.33 | 6.19 | 3.24 |
| P-212 | 309: J-113 | 117: J-89 | 10 | 1,502 | -104.15 | 0.11 | 0.43 |
| P-213 | 105: J-70 | 305: J-112 | 8 | 4,167 | -161.55 | 2.60 | 1.03 |
| P-214 | 115: J-87 | 112: J-83 | 8 | 2,446 | -697.36 | 22.92 | 4.45 |
| P-215 | 117: J-89 | 115: J-87 | 8 | 2,007 | -456.49 | 8.58 | 2.91 |
| P-216 | 156: T-1 | 317: J-115 | 36 | 133 | 18687.17 | 0.36 | 6.85 |
| P-217 | 317: J-115 | 132: J-80 | 36 | 836 | 18687.17 | 2.27 | 6.85 |
| P-222 | 326: PMP-1 | 156: T-1 | 24 | 4,923 | 0.00 | 0.00 | 0.00 |
| P-223 | 334: R-1 | 326: PMP-1 | 36 | 154 | 0.00 | 0.00 | 0.00 |

VALVE INFORMATION FOR FUTURE PEAK HOUR USE

| Label | Downstream Pipe | Elevation (ft) | Diameter (in) | Hydraulic Grade Setting (ft) | Initial Pressure Setting (psi) | From Pressure (psi) | To Pressure (psi) |
|--------|-----------------|----------------|---------------|------------------------------|--------------------------------|---------------------|-------------------|
| PRV-10 | 248: P-162 | 5172.00 | 24 | 5287.50 | 50.00 | 114.60 | 50.00 |
| PRV-12 | 252: P-169 | 5056.00 | 14 | 5165.50 | 47.40 | 92.50 | 47.40 |
| PRV-13 | 253: P-170 | 5056.00 | 30 | 5165.50 | 47.40 | 97.30 | 47.40 |
| PRV-14 | 256: P-184 | 4942.00 | 14 | 5057.50 | 50.00 | 70.00 | 50.00 |
| PRV-16 | 205: P-166 | 4942.00 | 24 | 5057.50 | 50.00 | 92.50 | 50.00 |
| PRV-20 | 273: P-197 | 5078.00 | 12 | 5165.50 | 37.90 | 40.00 | 89.40 |

TANK INFORMATION FOR FUTURE PEAK HOUR USE

| Label | Base Elevation (ft) | Maximum Elevation (ft) | Diameter (ft) | Level (Initial) (ft) | Level (Minimum) (ft) | Level (Maximum) (ft) |
|-------|---------------------|------------------------|---------------|----------------------|----------------------|----------------------|
| T-1 | 5412.00 | 5443.00 | 238.0 | 31.0 | 2.0 | 31.0 |
| T-2 | 5166.00 | 5196.00 | 64.0 | 30.0 | 2.0 | 30.0 |

JUNCTION INFORMATION FOR FUTURE FIRE FLOW W/ PEAK DAY USE

| Label | Satisfies Fire Flow Constraints? | Total Flow Available (gpm) | Calculated Residual Pressure (psi) | Pressure (Minimum) (psi) |
|-------|----------------------------------|----------------------------|------------------------------------|--------------------------|
| J-3 | TRUE | 2500.00 | 76.4 | 20.0 |
| J-4 | TRUE | 2500.00 | 67.6 | 20.0 |
| J-5 | TRUE | 2500.00 | 66.1 | 20.0 |
| J-6 | TRUE | 2500.00 | 57.8 | 20.0 |
| J-7 | TRUE | 2500.00 | 46.0 | 20.0 |
| J-8 | TRUE | 2500.00 | 38.0 | 20.0 |
| J-10 | TRUE | 2500.00 | 21.5 | 20.0 |
| J-11 | TRUE | 2500.00 | 44.7 | 20.0 |
| J-12 | TRUE | 2500.00 | 44.5 | 20.0 |
| J-13 | TRUE | 2500.00 | 44.8 | 20.0 |
| J-14 | TRUE | 2500.00 | 39.6 | 20.0 |
| J-15 | TRUE | 2500.00 | 35.8 | 20.0 |
| J-16 | TRUE | 2500.00 | 33.2 | 20.0 |
| J-17 | TRUE | 2500.00 | 27.2 | 20.0 |
| J-18 | TRUE | 2500.00 | 28.5 | 20.0 |
| J-19 | TRUE | 2500.00 | 34.3 | 20.0 |
| J-20 | TRUE | 2500.00 | 38.8 | 20.0 |
| J-21 | TRUE | 2500.00 | 32.2 | 20.0 |
| J-22 | TRUE | 2500.00 | 76.1 | 20.0 |
| J-24 | TRUE | 2500.00 | 38.7 | 20.0 |
| J-25 | TRUE | 2500.00 | 34.9 | 20.0 |
| J-26 | TRUE | 2500.00 | 35.2 | 20.0 |
| J-27 | FALSE | 0.00 | 12.6 | 20.0 |
| J-30 | TRUE | 2500.00 | 72.5 | 20.0 |
| J-33 | TRUE | 2500.00 | 95.1 | 20.0 |
| J-34 | TRUE | 2500.00 | 82.8 | 20.0 |
| J-35 | TRUE | 2500.00 | 74.8 | 20.0 |
| J-40 | TRUE | 2500.00 | 49.5 | 20.0 |
| J-59 | TRUE | 2500.00 | 62.3 | 20.0 |
| J-60 | TRUE | 2500.00 | 44.2 | 20.0 |
| J-61 | TRUE | 2500.00 | 64.6 | 20.0 |
| J-62 | TRUE | 2500.00 | 59.6 | 20.0 |
| J-63 | TRUE | 2500.00 | 54.1 | 20.0 |
| J-64 | TRUE | 2500.00 | 47.3 | 20.0 |
| J-65 | TRUE | 2500.00 | 50.9 | 20.0 |
| J-67 | TRUE | 2500.00 | 72.4 | 20.0 |
| J-69 | TRUE | 2500.00 | 47.5 | 20.0 |
| J-70 | TRUE | 2500.00 | 58.0 | 20.0 |
| J-73 | TRUE | 2500.00 | 70.4 | 20.0 |
| J-74 | TRUE | 2500.00 | 81.9 | 20.0 |
| J-75 | TRUE | 2500.00 | 56.5 | 20.0 |
| J-76 | TRUE | 2500.00 | 68.1 | 20.0 |
| J-78 | TRUE | 2500.00 | 73.3 | 20.0 |
| J-79 | TRUE | 1948.40 | 20.0 | 20.0 |

JUNCTION INFORMATION FOR FUTURE FIRE FLOW W/ PEAK DAY USE

| | | | | |
|-------|------|---------|-------|------|
| J-80 | TRUE | 2500.00 | 77.2 | 20.0 |
| J-81 | TRUE | 2500.00 | 49.1 | 20.0 |
| J-82 | TRUE | 2500.00 | 68.8 | 20.0 |
| J-83 | TRUE | 2500.00 | 66.9 | 20.0 |
| J-84 | TRUE | 2500.00 | 55.7 | 20.0 |
| J-85 | TRUE | 2500.00 | 51.4 | 20.0 |
| J-87 | TRUE | 2500.00 | 51.2 | 20.0 |
| J-89 | TRUE | 2500.00 | 45.9 | 20.0 |
| J-90 | TRUE | 2500.00 | 30.6 | 20.0 |
| J-91 | TRUE | 2500.00 | 78.5 | 20.0 |
| J-93 | TRUE | 2500.00 | 100.5 | 20.0 |
| J-94 | TRUE | 2500.00 | 44.8 | 20.0 |
| J-95 | TRUE | 2500.00 | 46.4 | 20.0 |
| J-97 | TRUE | 2500.00 | 31.8 | 20.0 |
| J-103 | TRUE | 2500.00 | 65.1 | 20.0 |
| J-104 | TRUE | 2500.00 | 100.4 | 20.0 |
| J-105 | TRUE | 2500.00 | 74.5 | 20.0 |
| J-107 | TRUE | 2500.00 | 95.8 | 20.0 |
| J-108 | TRUE | 2500.00 | 84.3 | 20.0 |
| J-112 | TRUE | 2500.00 | 66.7 | 20.0 |
| J-113 | TRUE | 2500.00 | 43.4 | 20.0 |
| J-115 | TRUE | 2500.00 | 20.7 | 20.0 |

* Junction 27 is located in close proximity to a storage tank

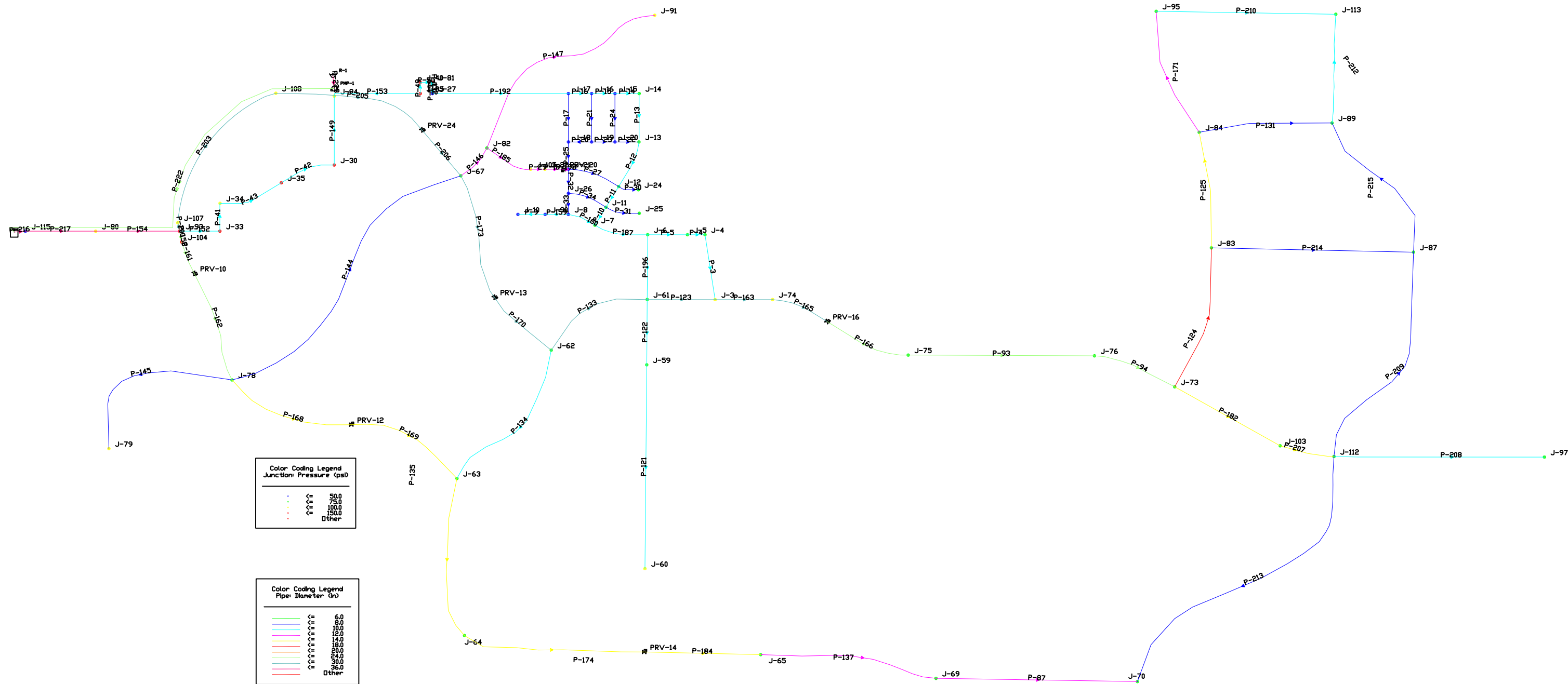

**Color Coding Legend
Junction Pressure (psi)**

| | |
|---|----------|
| • | <= 50.0 |
| • | <= 75.0 |
| • | <= 100.0 |
| • | <= 150.0 |
| • | Other |

**Color Coding Legend
Pipe Diameter (in)**

| | |
|---|---------|
| — | <= 6.0 |
| — | <= 8.0 |
| — | <= 10.0 |
| — | <= 12.0 |
| — | <= 14.0 |
| — | <= 16.0 |
| — | <= 18.0 |
| — | <= 20.0 |
| — | <= 24.0 |
| — | <= 30.0 |
| — | <= 36.0 |
| — | Other |

POLE CANYON WASTEWATER COLLECTION AND TREATMENT ANALYSIS

Table of Contents

| | |
|----------------------------------------------------------------|-----------|
| TABLE OF CONTENTS | 2 |
| INTRODUCTION | 3 |
| DEMOGRAPHIC AND POPULATION PROJECTION SUMMARY | 3 |
| WASTEWATER TREATMENT SYSTEM | 4 |
| OVERVIEW | 4 |
| EXISTING WASTEWATER SYSTEM INFRASTRUCTURE | 4 |
| <i>Collection System</i> | 4 |
| <i>Flow Capacities and Total Flow</i> | 4 |
| <i>Lagoon Storage and Treatment Capacities</i> | 6 |
| WASTEWATER TREATMENT SYSTEM | 7 |
| ANALYSIS AND RECOMMENDATIONS | 7 |
| EXISTING WASTEWATER TREATMENT..... | 7 |
| <i>Treatment Facility</i> | 7 |
| <i>Alternative One</i> | 7 |
| <i>Alternative Two</i> | 8 |
| <i>Existing System Alternative Costs</i> | 8 |
| <i>Selected Alternative</i> | 8 |
| WASTEWATER COLLECTION SYSTEM | 11 |
| <i>Proposed Pole Canyon Collection System Analysis</i> | 11 |
| APPENDIX | 16 |
| SEWERGEMS - COLLECTION SYSTEM MODEL ANALYSIS AND RESULTS | 16 |

Introduction

As the growth in Utah continues, the need for large developments also increases. The growth in Utah County is no exception to this fact. The growth in Utah County increases on the east side of the valley, and possibly at a higher pace on the west side of the valley. Pole Canyon is a planned large community with many amenities. The different types of zoning that will exist will include residential, commercial, open space and some light industrial.

The purpose of this sewer master plan report is to provide a basis and guide for wastewater infrastructure improvements necessary for the proposed development of Pole Canyon.

The proposed development will require a significant number of infrastructure improvement projects and will eventually be connecting to a different existing treatment facility. The existing facilities were constructed between the late 1970's and 1980's and are all part of the White Hills Water System. The new infrastructure will connect to the existing infrastructure and serve as the new backbone for the proposed developments.

Demographic and Population Projection Summary

The current demographics and future population projections for Pole Canyon were prepared in conjunction with the overall master plan and were completed in the Demographic Analysis portion of this report. Current and future population projections to build-out in year 2030 and corresponding Equivalent Residential Connections (ERC) are summarized in Table 1.

Table 1 – Equivalent Residential Connections

| Total | | Current | | Future (YR 2030) | |
|------------|--------|------------|-----|------------------|--------|
| Population | ERC | Population | ERC | Population | ERC |
| 34,224 | 15,597 | 424 | 121 | 33,800 | 15,476 |

Wastewater Treatment System Overview

Existing Wastewater System Infrastructure

In order to establish a master plan for new infrastructure for sewer collection, it is important to briefly review and understand the existing facilities that will become part of the Pole Canyon Sewer System. These existing facilities were installed as part of the subdivision in the late 1970's and early 80's. The system consists of 8-inch to 12-inch gravity flow pipelines and a total containment lagoon treatment facility, as shown in Figure 1. The system is currently owned and operated by the White Hills Special Service District (WHSSD). It is anticipated that WHSSD will continue to retain ownership and operation of the existing infrastructure. However, ownership and operation responsibilities may at some point be transferred to a new municipality, special service district or other body politic in the event municipal annexation of the property occurs.

Collection System

As stated previously, the existing collection and treatment system located within the Pole Canyon development area is part of the existing White Hills Subdivision. All piping is gravity flow ranging in size from 8-inch to 12-inch. Pipe material is concrete.

Flow Capacities and Total Flow

The main collector line located along Wilson Avenue is a 12-inch diameter pipe laid at 2.7% to 4.0% slope. For this analysis, total pipe capacity will be taken as flowing 75% full. Thus according to original construction drawings, the total capacity of the Wilson Avenue collector pipe is 1900 gallons per minute (gpm). The total capacity of the Wilson Avenue pipe has the ability to convey approximately 1900 gallons per minute (gpm).



Existing Lines (White Hills Subdivision)

Diameter

8"

12"

--- Development Boundary



POLE CANYON DEVELOPMENT

**POLE CANYON WASTEWATER TREATMENT MASTER PLAN
WASTEWATER COLLECTION AND TREATMENT ANALYSIS
EXISTING WASTEWATER COLLECTION SYSTEM**

| ORIGINAL | | DESIGN | | DRAWN | | CHECKED | |
|-----------|------------|--------|------|-------|------|---------|------|
| NO. | DATE | NO. | DATE | NO. | DATE | NO. | DATE |
| 1 | 07/21/2000 | MPM | MPM | MPM | MPM | | |
| REVISIONS | | | | | | | |
| | | | | | | | |
| | | | | | | | |
| | | | | | | | |

AQUA
ENGINEERING, INC.
553 W. 2600 S., SUITE 275 BOUNTIFUL, UT 84010
PHONE (801) 298-1327 FAX (801) 298-0153

FIGURE

1

As previously stated in the demographic section, an residential ERC equals 3.5 persons per household. For planning purposes, according to data of surrounding communities a conservative 60 gallons per day per capita (gpd) should be used when designing new wastewater utilities. Thus each household or ERC connection is approximated at 210 gallons per day (gpd). Based on this flow rate, the Wilson Avenue collector has a flow capacity to service approximately 13,000 ERCs. Figure 2 shows the measured flow of the White Hills Subdivision during four days in March 2007. The measured average flow during that time was 27 gpm, 39,000 gpd or 111 ERCs. The Wilson Avenue pipe has capacity for an additional 12,890 ERCs. The current population of the White Hills Subdivision is approximately 424 persons. Using an average daily flow of 60 gallons per capita, the area conservatively produces 25,400 gpd.

Lagoon Storage and Treatment Capacities

The WHSSD has three total containment lagoons with a total combined area of approximately 292,000 square feet (sq. ft.) or 6.7 acres (ac.). These three lagoons receive flow from the White Hills Subdivision and are used to store and treat the wastewater. The lagoons have a hydraulic capacity of approximately 45,000 gallons per day, assuming typical infiltration, evaporation and precipitation rates for the area. With a relatively small increase in population, the lagoons will be at the hydraulic capacity and will require additional cells. The Pole Canyon Development will add approximately 33,800 more persons or approximately 15,476 ERC. An expansion of the lagoon treatment facility to handle the increased flow would require excessive amounts of land unless they were converted to discharging lagoons. It has been the goal of the State to regionalize wastewater treatment to the maximum possible to minimize points of discharge and thus possible violations and other ecological issues associated with wastewater treatment. For these reasons, it is proposed that all wastewater flow be conveyed to a regional plant such as that existing in Eagle Mountain City.

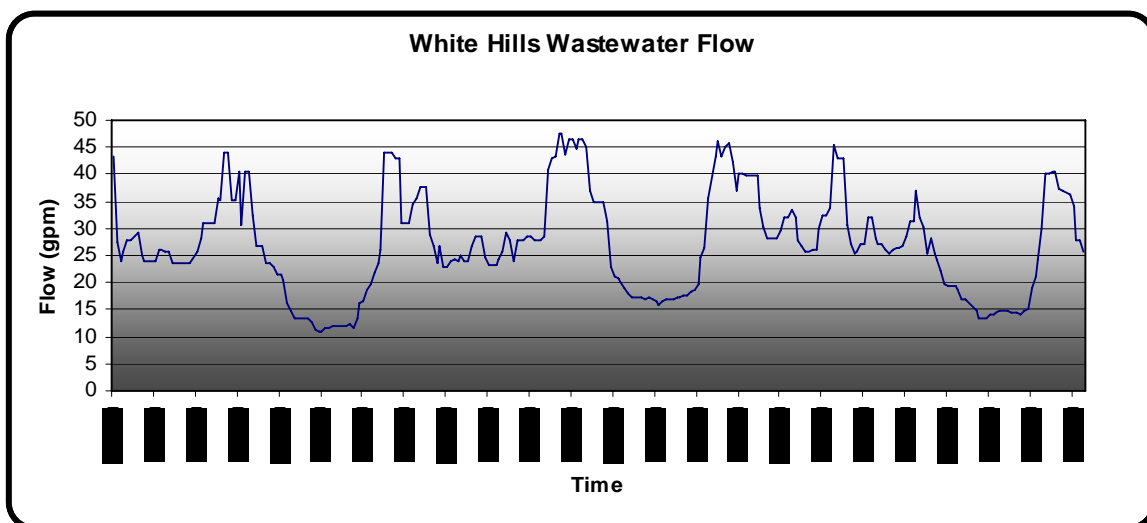

Figure 2 – The Measured Flow of the White Hills Subdivision

Wastewater Treatment System Analysis and Recommendations

Existing Wastewater Treatment

Treatment Facility

As stated previously, the WHSSD has three lagoons that have a hydraulic capacity of 45,000 gallons per day. The current flow from the White Hills Subdivision is nearing that flow limit. As development progresses within the Pole Canyon Boundary, the treatment capacity of the existing facilities will quickly be exceeded requiring a wastewater treatment alternative. Two proposed alternatives are detailed in the subsequent pages.

Alternative One

Rehabilitate and repair the existing treatment lagoons. The White Hills Subdivision has effectively reached built-out condition and has a well functioning collection system. The first alternative involves the repair and rehabilitation of the existing treatment lagoons. The lagoons would be used exclusively by the White Hills Subdivision due to the fact that the treatment lagoons currently operate at or near hydraulic capacity. The existing treatment lagoons (as shown in Figure 3) are adequately sized to store and treat the current flow conditions; however, through the years they have fallen into disrepair. The lagoons contain original clay liners which have dried and cracked allowing partially treated wastewater to percolate into the substrata which could pose serious health issues in regards to groundwater supplies. This is an issue that must be rectified. While rehabilitating the ponds would protect groundwater supplies, this option would most likely be classified as a maintenance issue and therefore previously collected impact fees may not be available to assist in funding.



Figure 3 – The Existing Treatment Lagoon Cells One and Two, respectively

In order to keep the treatment lagoons in operation for the existing White Hills Subdivision residents, some repairs and rehabilitation will need to be performed. Each cell of the lagoons will need to be grubbed, regraded, and re-surfaced with

rip-rap in order to meet State requirements. To insure that the lagoons are able to independently contain the wastewater, they will need to be relined and/or re-sealed using either a synthetic or natural liner. The headworks to the lagoons will also need to be upgraded with flow metering capacities. In addition to construction efforts, permitting efforts will be required in order to comply with State standards.

Alternative Two

The second alternative involves abandoning the existing lagoons and connecting to the proposed wastewater collection utilities to be constructed for the Pole Canyon Development. It is anticipated that the Pole Canyon System will convey wastewater to the existing Eagle Mountain treatment facility via a to-be-constructed collector pipeline. It should be noted that conveying wastewater to the Eagle Mountain Treatment plant would be considered a system improvement and thus would qualify for usage of previously collected impact fee funds. The timing of the bypass would take place after the proposed Pole Canyon System was constructed to minimize service disruption to the residents. The lagoons would continue to operate during the construction of the new line. The 12-inch Wilson Avenue collector from White Hills Subdivision would be increased to 18-inches along SR-73. See Figure 4 for this change to the existing wastewater collection system. The Pole Canyon Development collection system will be comprised of PVC interceptor and collector lines that range from 8-inches to 30-inches in diameter. The wastewater flow would be conveyed to the southeast of the development and eventually to the regional wastewater treatment facility to the east comprised of a 30-inch trunkline and a lift station, near Eagle Mountain. Table 1 shows the cost estimates for the two different alternatives.

Existing System Alternative Costs

Table 1 – The Cost Estimates for Alternatives One and Two

| Alternative Costs | | | | | | |
|-------------------|------|----------------------------------------|--------------|------|-----------|------------|
| Option | Item | Description | Quantity | Unit | Unit Cost | Total Cost |
| Alternative One | 1 | Clear, Grub, Grade and Rip rap Lagoons | 1 | Lump | \$100,000 | \$100,000 |
| | 2 | Import & Compact Clay Liner | 1 | Lump | \$175,000 | \$175,000 |
| | 3 | Headworks Upgrade | 1 | Lump | \$25,000 | \$25,000 |
| | 4 | Permit Compliance | 1 | Lump | \$15,000 | \$15,000 |
| | | | Total | | | |
| Alternative Two | 5 | 18" Sewer line Installation | 800 | feet | \$65 | \$52,000 |
| | | | Total | | | |

Alternative #2 does not include the costs for the 30-inch trunkline and lift station that will convey the flow from Pole Canyon to the Eagle Mountain Wastewater Treatment Facility. These costs are included in Table #3.

Selected Alternative

The selected and preferred alternative is Alternative #2. This option allows for a modernized collection and treatment of wastewater and provides for a regionalized

facility for the area. The treatment facility is functioning with trained operators and maintenance personnel. Finally, the overall capital costs and O&M costs of Alternative #1 are substantially more significant than those of alternative #2. It should be noted that the costs associated with alternative #2 above reflect the cost of connecting the existing White Hills sewer collection system to the proposed Pole Canyon collection system. The combined systems will then be conveyed to the Eagle Mountain Wastewater Treatment Facility.

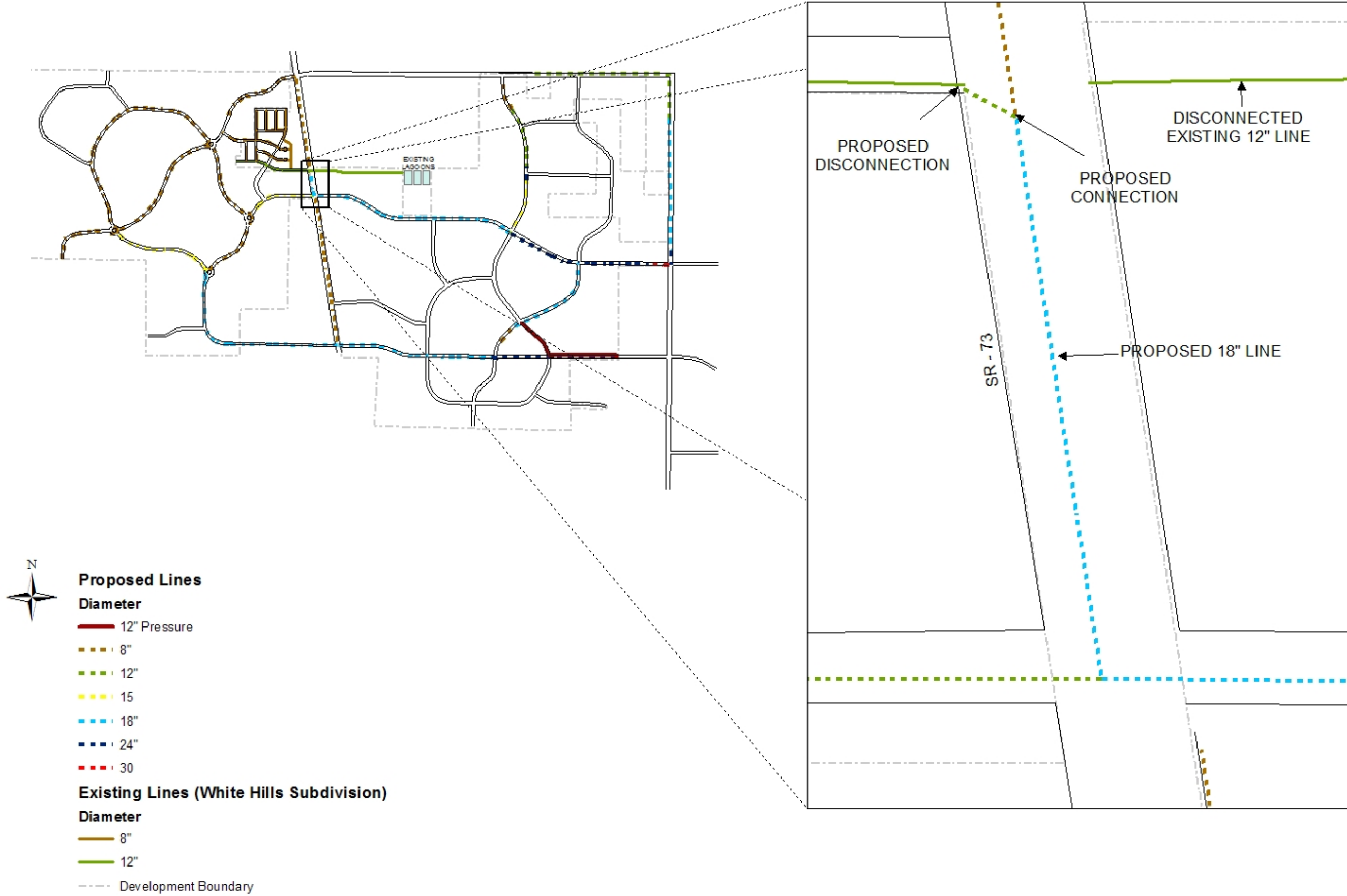

POLE CANYON DEVELOPMENT

POLE CANYON WASTEWATER TREATMENT MASTER PLAN
 WASTEWATER COLLECTION AND TREATMENT ANALYSIS
 PROPOSED CONNECTION TO POLE CANYON SYSTEM

| ORIGINAL | | REVISIONS | |
|----------|------------|-----------|---------|
| NO. | DATE | DESIGN | CHECKED |
| 1 | 07/21/2008 | MPM | DMH |
| | | | |
| | | | |
| | | | |



FIGURE
4

Wastewater Collection System

Proposed Pole Canyon Collection System Analysis

In accordance with Utah State Administrative Code - Design Requirements for Wastewater Collection, Treatment, and Disposal Systems R317-3; existing sewer systems shall be analyzed on the basis of an annual average daily rate of flow. For this wastewater master plan an average annual flow rate of 60 gallons per day per capita (gpcd) was used.

The analysis was performed using the sanitary sewer modeling and management software SewerGEMs. Pipe sizes were determined using the flow rate of 60 gpcd discussed above, a roughness coefficient of 0.013, at least the minimum slope for a given diameter, and peaking factor of 3.0 applied. The flows were based on the density of the area as provided by ASWN+ Planners and Horrocks Engineers. The areas are listed in Table 2, along with the assumed densities for each area. Figure 5 shows Pole Canyon Development along with the names of the areas. The collection system lines were designed to allow sufficient capacity during peak flows. Collection lines sized 8-inch thru 15-inch were designed to allow a capacity of at least 50% during peak flow. All sewer lines 18-inch or larger were designed with a capacity of at least 75% during peak flow. Because location of individual housing units is not known, flows from each area were equally distributed to all the manholes within that given area boundary. The results from the analysis are found in the appendix.

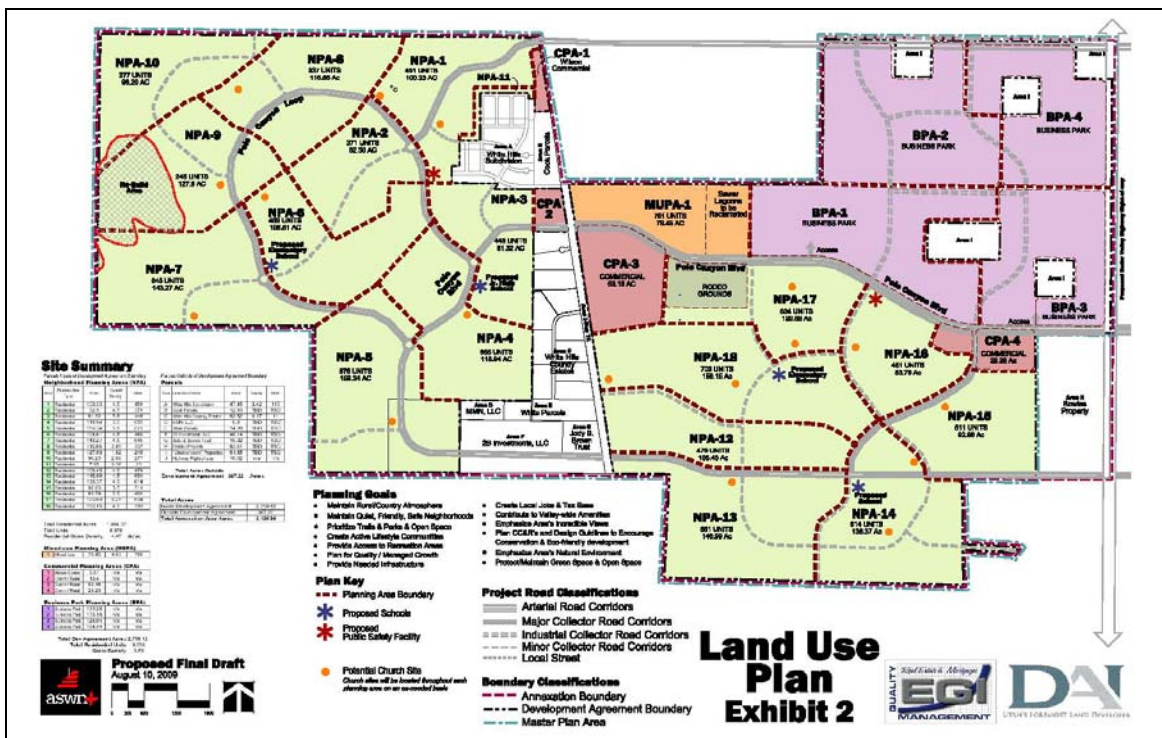

Figure 5 - Pole Canyon Development Concept Plan

Table 2 - The Development Areas and Densities

| Neighborhood Planning Areas (NPA) | | | | |
|--------------------------------------------|---------------------|--------|-----------------|-------------|
| Planning Area | Planning Area Type | Acres | Overall Density | Total Units |
| 1 | Residential | 100.33 | 4.5 | 451 |
| 2 | Residential | 82.5 | 4.5 | 371 |
| 3 | Residential | 81.32 | 5.5 | 447 |
| 4 | Residential | 118.94 | 5.5 | 654 |
| 5 | Residential | 159.34 | 5.5 | 876 |
| 6 | Residential | 108.61 | 4.5 | 489 |
| 7 | Residential | 143.27 | 4.5 | 645 |
| 8 | Residential | 116.66 | 2.89 | 337 |
| 9 | Residential | 127.9 | 1.92 | 246 |
| 10 | Residential | 96.2 | 2.88 | 277 |
| 11 | Residential | 5.95 | 3.36 | 20 |
| 12 | Residential | 106.45 | 4.5 | 479 |
| 13 | Residential | 146.99 | 4.5 | 661 |
| 14 | Residential | 136.37 | 4.5 | 614 |
| 15 | Residential | 92.86 | 5.5 | 511 |
| 16 | Residential | 83.79 | 5.5 | 461 |
| 17 | Residential | 120.69 | 5.25 | 634 |
| 18 | Residential | 156.15 | 4.5 | 703 |
| Mixed-use Planning Area (MUPA) | | | | |
| 1 | Mixed Use | 65.09 | 12 | 781 |
| *Commercial Planning Areas (CPA) | | | | |
| 1 | Wilson Commercial | 5.57 | 5 | 28 |
| 2 | Commercial / Retail | 10.4 | 5 | 52 |
| 3 | Commercial / Retail | 63.18 | 5 | 316 |
| 4 | Commercial / Retail | 28.26 | 5 | 141 |
| *Business Park Planning Areas (BPA) | | | | |
| 1 | Business Park | 170.28 | 9 | 1533 |
| 2 | Business Park | 133.18 | 9 | 1199 |
| 3 | Business Park | 129.04 | 9 | 1161 |
| 4 | Business Park | 154.44 | 9 | 1390 |

Utilizing all the assumptions stated above, the current and proposed wastewater collection systems were analyzed to understand the system and establish system upgrades necessary to accommodate the development's buildout capacity. Overall, the system flows in a easterly direction; therefore, as the collected flow increases towards the center of the development, the diameter of the trunk lines

will need to be increased. This also applies to the trunkline conveying the flow from the Pole Canyon development to the Eagle Mountain wastewater treatment facility. The trunkline will be sized appropriately to convey the wastewater at a rate of 2 feet per second. A trunkline of 18" may be adequate for the first ten to fifteen years before needing to be upsized. The wastewater collection system has also been divided into different construction priorities. Constructing the entire infrastructure including the collection lines, in one large project phase, would not be recommended. One portion of the sewer collection system will require a lift station to transfer the flow. The lift station may also be phased for adequate pumping. A reasonable pumping volume for the first ten years would be estimated at 500 gpm. The buildout pumping volume would be estimated at 750 gpm for average flow with the maximum volume being estimated at 1,700 gpm. The cost estimate reflects the phased sizing.

Figure 6 shows the proposed collection lines along with the conceptual priorities. The conceptual prioritization of the collection system was determined assuming a higher rate of residential development than commercial and light industrial development. It should be noted that these construction priorities may be altered throughout the project to facilitate the then current development plans. Table 3 outlines the different proposed priorities and the associated costs. All upgrades are system upgrades and should be attributable to growth and thus impact fee eligible.

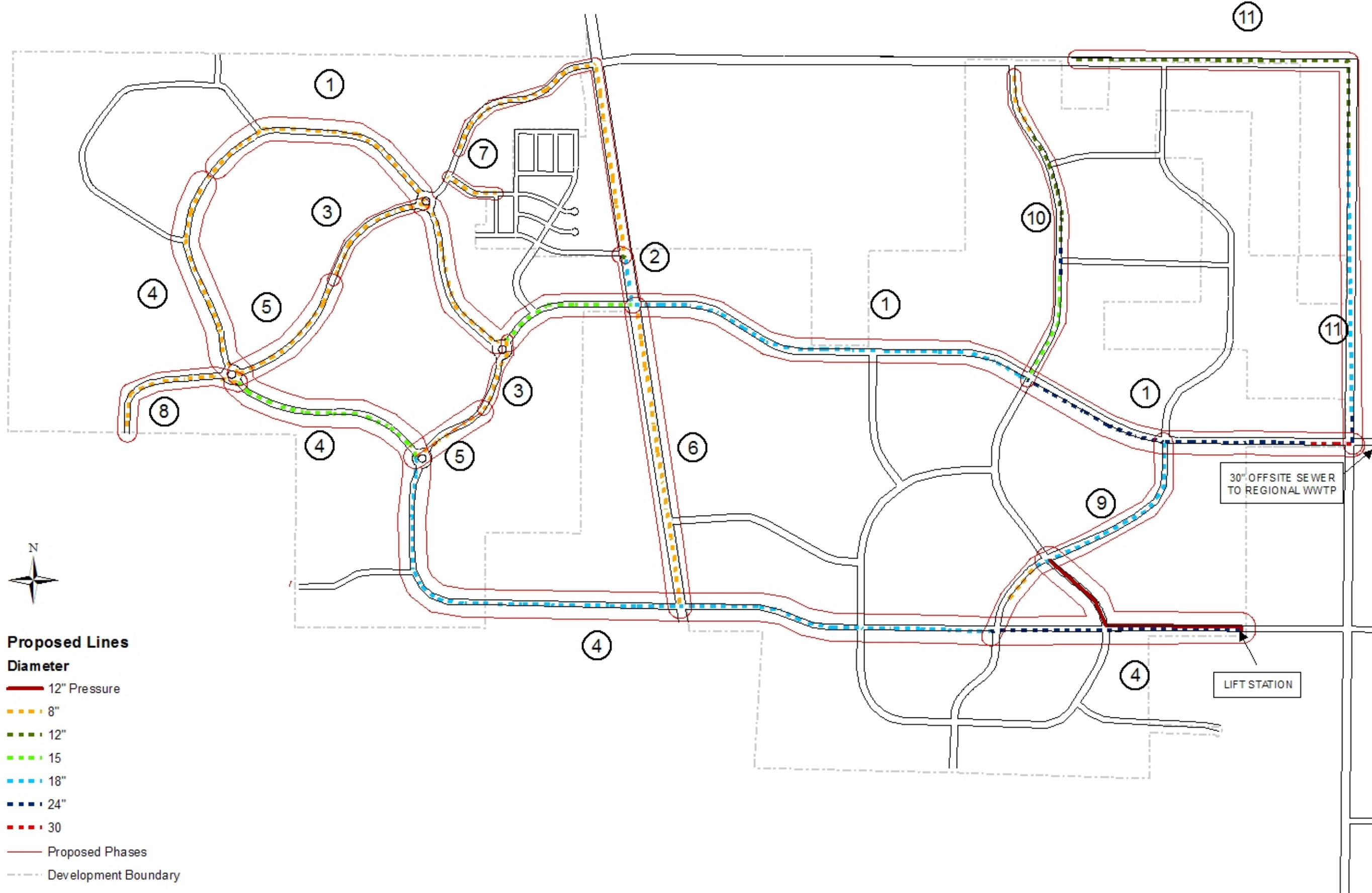

Proposed Lines

Diameter

- 12" Pressure
- - - 8"
- - - 12"
- - - 15"
- - - 18"
- - - 24"
- - - 30"

— Proposed Phases

- - - Development Boundary



| ORIGINAL | | REVISIONS | |
|----------|----------|-----------|---------|
| NO. | DATE | DESIGN | CHECKED |
| 1 | 07/21/00 | MFM | DMH |
| | | | |
| | | | |

POLE CANYON DEVELOPMENT

POLE CANYON WASTEWATER TREATMENT MASTER PLAN

WASTEWATER COLLECTION AND TREATMENT ANALYSIS

PROPOSED DEVELOPMENT PRIORITIES

AQUA
ENGINEERING, INC.

553 W. 2600 S., SUITE 275 BOUNTIFUL, UT 84010
PHONE (801) 298-1327 FAX (801) 298-0153

Table 3 – Wastewater Collection System Phases – Installation Costs

| Wastewater System Costs | | | | | |
|--------------------------------|----------------------------------|-----------------|-------------|------------------|--------------------|
| Priority | Description | Quantity | Unit | Unit Cost | Total Cost |
| 1 | 8" Collection Line Installation | 5,200 | feet | \$30 | \$156,000 |
| | 15" Collection Line Installation | 2,000 | feet | \$45 | \$90,000 |
| | 18" Collection Line Installation | 5,900 | feet | \$55 | \$324,500 |
| | 24" Collection Line Installation | 4,000 | feet | \$65 | \$260,000 |
| | 30" Collection Line Installation | 650 | feet | \$70 | \$45,500 |
| | Lift Station to Eagle Mtn WWTP | 1 | Lump | \$500,000 | \$500,000 |
| | 30" Collection Line Installation | 11,000 | feet | \$70 | \$770,000 |
| | | | | | \$2,146,000 |
| 2 | 12" Collection Line Installation | 100 | feet | \$40 | \$4,000 |
| | 18" Collection Line Installation | 700 | feet | \$55 | \$38,500 |
| | | | | | \$42,500 |
| 3 | 8" Collection Line Installation | 2,800 | feet | \$30 | \$84,000 |
| | | | | | \$84,000 |
| 4 | 8" Collection Line Installation | 3,600 | feet | \$30 | \$108,000 |
| | 12" Collection Line Installation | 150 | feet | \$40 | \$6,000 |
| | 15" Collection Line Installation | 2,800 | feet | \$45 | \$126,000 |
| | 18" Collection Line Installation | 9,950 | feet | \$55 | \$547,250 |
| | 24" Collection Line Installation | 6,000 | feet | \$65 | \$390,000 |
| | 12" Pressure Line Installation | 3,200 | feet | \$40 | \$128,000 |
| | Lift Station | 1 | Lump | \$225,000 | \$225,000 |
| | Lift Station - expansion | 1 | Lump | \$100,000 | \$100,000 |
| | | | | | \$1,630,250 |
| 5 | 8" Collection Line Installation | 3,000 | feet | \$30 | \$90,000 |
| | | | | | \$90,000 |
| TOTAL | 0-5 YEAR PROJECTS | | | | \$3,992,750 |
| 6 | 8" Collection Line Installation | 4,200 | feet | \$30 | \$126,000 |
| | | | | | \$126,000 |
| 7 | 8" Collection Line Installation | 6,150 | feet | \$30 | \$184,500 |
| | | | | | \$184,500 |
| 8 | 8" Collection Line Installation | 2,100 | feet | \$30 | \$63,000 |
| | | | | | \$63,000 |
| | 8" Collection Line Installation | 500 | feet | \$30 | \$15,000 |
| 9 | 18" Collection Line Installation | 3,100 | feet | \$55 | \$170,500 |
| | | | | | \$185,500 |
| TOTAL | 5-10 YEAR PROJECTS | | | | \$559,000 |
| | 8" Collection Line Installation | 800 | feet | \$30 | \$24,000 |
| | 12" Collection Line Installation | 2,000 | feet | \$40 | \$80,000 |
| 10 | 15" Collection Line Installation | 1,600 | feet | \$45 | \$72,000 |
| | | | | | \$176,000 |
| | 12" Collection Line Installation | 5,900 | feet | \$40 | \$236,000 |
| | 18" Collection Line Installation | 2,800 | feet | \$55 | \$154,000 |
| 11 | 24" Collection Line Installation | 400 | feet | \$65 | \$26,000 |
| | | | | | \$416,000 |
| TOTAL | 10-15 YEAR PROJECTS | | | | \$592,000 |

SewerGEMs - Collection System Model Analysis and Results

Calculation Executive Summary

Scenario

Label Pole Canyon Existing (White Hills)

Storm Event

Label Base Rainfall Runoff

Global Storm Event <None>

Return Event 0 years

Calculation Executive Summary

| | |
|------------------------------|------------|
| Total Inflow Volume | 40,051 gal |
| Total System Outflow Volume | 42,215 gal |
| Total System Overflow Volume | 0 gal |
| Total Gutter Volume Change | (N/A) gal |
| Total System Volume Change | 1,238 gal |
| Continuity Error | 8.1 % |
| Total N-R Iterations | 882 |

Calculation Executive Summary

Scenario

| | |
|-------|------------|
| Label | Peak Flows |
|-------|------------|

Storm Event

| | | |
|--------------------|----------------------|---------|
| Label | Base Rainfall Runoff | 0 years |
| Global Storm Event | <None Selected> | |

Calculation Executive Summary

| | | |
|------------------------------|-------------|------------|
| Total Inflow Volume | 5571675 gal | 141023 gal |
| Total System Outflow Volume | 2029235 gal | 61 % |
| Total System Overflow Volume | 0 gal | 2153 |
| Total Gutter Volume Change | (N/A) gal | |

Pole Canyon Development - Conduit Analysis

| Label | Start-node Id | Stop-node Id | Constructed Slope (ft/ft) | Diameter (in) | Material | Manning's (n) | Full Capacity (ft ³ /s) | Maximum Flow (ft ³ /s) | Ever Overflowing/Surcharged? | Maximum Velocity (ft/s) | Length |
|-------|---------------|--------------|---------------------------|---------------|----------|---------------|------------------------------------|-----------------------------------|------------------------------|-------------------------|--------|
| CO-9 | 51: MH-12 | 54: MH-14 | -0.03 | 12 | PVC | 0.013 | 6.13 | 0.12 | FALSE | 2.97 | 265.6 |
| CO-10 | 54: MH-14 | 56: MH-15 | -0.031 | 12 | PVC | 0.013 | 6.31 | 0.12 | FALSE | 3.17 | 213.3 |
| CO-11 | 358: MH-155 | 227: MH-91 | 0.004 | 18 | PVC | 0.013 | 6.48 | 2.5 | FALSE | 2.85 | 315 |
| CO-11 | 56: MH-15 | 58: MH-16 | -0.029 | 12 | PVC | 0.013 | 6.1 | 0.03 | FALSE | 1.08 | 463.7 |
| CO-12 | 322: MH-137 | 669: MH-7 | -0.022 | 8 | PVC | 0.013 | 1.79 | 0 | FALSE | 0 | 483.5 |
| CO-12 | 58: MH-16 | 60: MH-17 | -0.045 | 12 | PVC | 0.013 | 7.53 | 0.03 | FALSE | 0.94 | 322.4 |
| CO-13 | 669: MH-7 | 324: MH-138 | -0.005 | 8 | PVC | 0.013 | 0.83 | 0 | FALSE | 0 | 472.4 |
| CO-13 | 60: MH-17 | 62: MH-18 | -0.038 | 12 | PVC | 0.013 | 6.95 | 0.02 | FALSE | 0.63 | 236.6 |
| CO-14 | 322: MH-137 | 680: MH-8 | -0.033 | 18 | PVC | 0.013 | 18.95 | 2.76 | FALSE | 7.51 | 345 |
| CO-14 | 62: MH-18 | 64: MH-19 | -0.039 | 12 | PVC | 0.013 | 7.05 | 0.01 | FALSE | 0.54 | 274.6 |
| CO-15 | 680: MH-8 | 438: MH-195 | -0.009 | 18 | PVC | 0.013 | 9.75 | 2.76 | FALSE | 4.71 | 410.9 |
| CO-15 | 64: MH-19 | 66: MH-20 | -0.029 | 12 | PVC | 0.013 | 6.08 | 0 | FALSE | 0 | 255.8 |
| CO-16 | 282: MH-117 | 735: OF-2 | 0.005 | 24 | PVC | 0.013 | 16.53 | 4.28 | FALSE | 4.39 | 299.8 |
| CO-16 | 56: MH-15 | 68: MH-21 | -0.026 | 8 | PVC | 0.013 | 1.95 | 0.09 | FALSE | 2.71 | 293.1 |
| CO-17 | 68: MH-21 | 70: MH-22 | -0.024 | 8 | PVC | 0.013 | 1.88 | 0.07 | FALSE | 2.31 | 293.6 |
| CO-18 | 70: MH-22 | 72: MH-23 | -0.027 | 8 | PVC | 0.013 | 1.99 | 0.04 | FALSE | 1.25 | 153.3 |
| CO-19 | 72: MH-23 | 74: MH-24 | -0.012 | 8 | PVC | 0.013 | 1.31 | 0.04 | FALSE | 1.7 | 253.1 |
| CO-20 | 74: MH-24 | 76: MH-25 | -0.013 | 8 | PVC | 0.013 | 1.37 | 0.04 | FALSE | 1.57 | 266.9 |
| CO-21 | 76: MH-25 | 78: MH-26 | -0.016 | 8 | PVC | 0.013 | 1.54 | 0 | FALSE | 0.16 | 309.1 |
| CO-22 | 78: MH-26 | 80: MH-27 | -0.01 | 8 | PVC | 0.013 | 1.22 | 0 | FALSE | 0.1 | 287 |
| CO-22 | 344: MH-148 | 346: MH-149 | 0.002 | 8 | PVC | 0.013 | 0.51 | 0.24 | FALSE | 1.29 | 400 |
| CO-23 | 580: MH-264 | 737: MH-10 | -0.001 | 8 | PVC | 0.013 | 0.4 | 0 | FALSE | 0 | 396.5 |
| CO-23 | 82: MH-28 | 83: MH-29 | 0.033 | 8 | PVC | 0.013 | 2.2 | 0.01 | FALSE | 0.28 | 281.7 |
| CO-24 | 83: MH-29 | 85: MH-30 | 0.062 | 8 | PVC | 0.013 | 3.02 | 0.02 | FALSE | 0.65 | 317.3 |
| CO-25 | 85: MH-30 | 87: MH-31 | 0.023 | 8 | PVC | 0.013 | 1.85 | 0.02 | FALSE | 0.61 | 417.1 |
| CO-29 | 92: MH-33 | 64: MH-19 | 0.027 | 8 | PVC | 0.013 | 1.98 | 0 | FALSE | 0 | 413.8 |
| CO-33 | 98: MH-35 | 100: MH-36 | 0.037 | 8 | PVC | 0.013 | 2.31 | 0 | FALSE | 0 | 410.7 |
| CO-37 | 106: MH-39 | 108: MH-40 | 0.042 | 8 | PVC | 0.013 | 2.49 | 0.01 | FALSE | 0.45 | 276.9 |
| CO-38 | 108: MH-40 | 76: MH-25 | 0.043 | 8 | PVC | 0.013 | 2.5 | 0.03 | FALSE | 0.8 | 275.6 |
| CO-41 | 116: MH-44 | 117: MH-45 | 0.015 | 8 | PVC | 0.013 | 1.46 | 0 | FALSE | 0 | 408.2 |
| CO-42 | 117: MH-45 | 83: MH-29 | 0.021 | 8 | PVC | 0.013 | 1.73 | 0 | FALSE | 0.14 | 459.2 |
| CO-45 | 122: MH-47 | 124: MH-48 | 0.023 | 8 | PVC | 0.013 | 1.82 | 0 | FALSE | 0.12 | 265.8 |
| CO-46 | 124: MH-48 | 108: MH-40 | 0.019 | 8 | PVC | 0.013 | 1.67 | 0.01 | FALSE | 0.2 | 314.7 |
| CO-47 | 120: MH-46 | 129: MH-49 | 0.022 | 8 | PVC | 0.013 | 1.81 | 0 | FALSE | 0 | 268.9 |
| CO-48 | 129: MH-49 | 106: MH-39 | 0.019 | 8 | PVC | 0.013 | 1.67 | 0 | FALSE | 0.14 | 314.7 |
| CO-49 | 111: MH-41 | 62: MH-18 | 0.026 | 8 | PVC | 0.013 | 1.97 | 0 | FALSE | 0 | 419.6 |
| CO-50 | 87: MH-31 | 70: MH-22 | 0.03 | 8 | PVC | 0.013 | 2.08 | 0.02 | FALSE | 0.64 | 289.2 |
| CO-51 | 100: MH-36 | 68: MH-21 | 0.036 | 8 | PVC | 0.013 | 2.29 | 0.01 | FALSE | 0.27 | 353.6 |
| CO-56 | 82: MH-28 | 153: MH-54 | -0.056 | 8 | PVC | 0.013 | 2.86 | 0.01 | FALSE | 0.3 | 367.4 |
| CO-57 | 153: MH-54 | 155: MH-55 | -0.049 | 8 | PVC | 0.013 | 2.68 | 0 | FALSE | 0.16 | 377.5 |
| CO-59 | 157: MH-56 | 159: MH-57 | 0.005 | 8 | PVC | 0.013 | 0.83 | 0.05 | FALSE | 1.58 | 400 |
| CO-60 | 159: MH-57 | 161: MH-58 | 0.019 | 8 | PVC | 0.013 | 1.65 | 0.11 | FALSE | 2.79 | 400 |
| CO-61 | 161: MH-58 | 163: MH-59 | 0.036 | 8 | PVC | 0.013 | 2.28 | 0.16 | FALSE | 3.8 | 400 |
| CO-62 | 163: MH-59 | 165: MH-60 | 0.04 | 8 | PVC | 0.013 | 2.41 | 0.21 | FALSE | 3.9 | 400 |
| CO-63 | 165: MH-60 | 167: MH-61 | 0.028 | 8 | PVC | 0.013 | 2.04 | 0.26 | FALSE | 3.74 | 400 |
| CO-64 | 167: MH-61 | 169: MH-62 | 0.043 | 8 | PVC | 0.013 | 2.51 | 0.31 | FALSE | 4.65 | 400 |
| CO-65 | 169: MH-62 | 171: MH-63 | 0.018 | 8 | PVC | 0.013 | 1.63 | 0.36 | FALSE | 3.56 | 400 |
| CO-66 | 171: MH-63 | 173: MH-64 | 0.01 | 8 | PVC | 0.013 | 1.21 | 0.42 | FALSE | 2.98 | 400 |
| CO-67 | 173: MH-64 | 175: MH-65 | 0.019 | 8 | PVC | 0.013 | 1.66 | 0.48 | FALSE | 3.95 | 400 |
| CO-68 | 175: MH-65 | 177: MH-66 | 0.016 | 8 | PVC | 0.013 | 1.53 | 0.47 | FALSE | 3.71 | 400 |
| CO-69 | 177: MH-66 | 179: MH-67 | 0.02 | 8 | PVC | 0.013 | 1.71 | 0.47 | FALSE | 3.97 | 400 |
| CO-70 | 179: MH-67 | 181: MH-68 | 0.025 | 8 | PVC | 0.013 | 1.91 | 0.47 | FALSE | 4.3 | 400 |
| CO-72 | 183: MH-69 | 185: MH-70 | 0.01 | 18 | PVC | 0.013 | 10.43 | 0.6 | FALSE | 3.09 | 400 |
| CO-73 | 185: MH-70 | 187: MH-71 | 0.027 | 18 | PVC | 0.013 | 17.11 | 0.6 | FALSE | 3.55 | 198 |
| CO-74 | 187: MH-71 | 189: MH-72 | 0.029 | 18 | PVC | 0.013 | 18.03 | 1.98 | FALSE | 6.67 | 400 |
| CO-75 | 189: MH-72 | 191: MH-73 | 0.028 | 18 | PVC | 0.013 | 17.42 | 2.1 | FALSE | 6.61 | 400 |
| CO-76 | 191: MH-73 | 193: MH-74 | 0.032 | 18 | PVC | 0.013 | 18.83 | 2.22 | FALSE | 7.11 | 400 |
| CO-77 | 193: MH-74 | 195: MH-75 | 0.029 | 18 | PVC | 0.013 | 17.76 | 2.34 | FALSE | 6.91 | 400 |
| CO-78 | 195: MH-75 | 197: MH-76 | 0.031 | 18 | PVC | 0.013 | 18.36 | 2.46 | FALSE | 7.18 | 400 |
| CO-79 | 197: MH-76 | 199: MH-77 | 0.025 | 18 | PVC | 0.013 | 16.68 | 2.58 | FALSE | 6.79 | 400 |
| CO-80 | 199: MH-77 | 201: MH-78 | 0.023 | 18 | PVC | 0.013 | 16.08 | 2.69 | FALSE | 6.7 | 400 |

Pole Canyon Development - Conduit Analysis

| Label | Start-node Id | Stop-node Id | Constructed Slope (ft/ft) | Diameter (in) | Material | Manning's (n) | Full Capacity (ft ³ /s) | Maximum Flow (ft ³ /s) | Ever Overflowing/Surcharged? | Maximum Velocity (ft/s) | Length |
|--------|---------------|--------------|---------------------------|---------------|----------|---------------|------------------------------------|-----------------------------------|------------------------------|-------------------------|--------|
| CO-81 | 201: MH-78 | 203: MH-79 | 0.019 | 18 | PVC | 0.013 | 14.3 | 2.81 | FALSE | 6.23 | 400 |
| CO-82 | 203: MH-79 | 205: MH-80 | 0.018 | 18 | PVC | 0.013 | 14.24 | 2.93 | FALSE | 6.3 | 400 |
| CO-83 | 205: MH-80 | 207: MH-81 | 0.016 | 18 | PVC | 0.013 | 13.44 | 3.15 | FALSE | 6.16 | 400 |
| CO-84 | 207: MH-81 | 209: MH-82 | 0.011 | 18 | PVC | 0.013 | 11.13 | 3.38 | FALSE | 5.49 | 400 |
| CO-85 | 209: MH-82 | 211: MH-83 | 0.009 | 18 | PVC | 0.013 | 9.82 | 3.61 | FALSE | 5.1 | 400 |
| CO-86 | 211: MH-83 | 213: MH-84 | 0.008 | 18 | PVC | 0.013 | 9.16 | 3.84 | FALSE | 4.92 | 400 |
| CO-87 | 213: MH-84 | 215: MH-85 | 0.007 | 18 | PVC | 0.013 | 8.47 | 4.06 | FALSE | 4.71 | 400 |
| CO-88 | 215: MH-85 | 217: MH-86 | 0.022 | 18 | PVC | 0.013 | 15.58 | 4.29 | FALSE | 5.89 | 227 |
| CO-89 | 217: MH-86 | 219: MH-87 | 0.003 | 24 | PVC | 0.013 | 12.39 | 5.74 | FALSE | 3.9 | 400 |
| CO-90 | 219: MH-87 | 221: MH-88 | 0.003 | 24 | PVC | 0.013 | 12.39 | 5.9 | FALSE | 3.93 | 400 |
| CO-91 | 221: MH-88 | 223: MH-89 | 0.003 | 24 | PVC | 0.013 | 12.39 | 6.07 | FALSE | 3.96 | 400 |
| CO-92 | 223: MH-89 | 225: MH-90 | 0.003 | 24 | PVC | 0.013 | 12.59 | 6.23 | FALSE | 4.02 | 400 |
| CO-93 | 225: MH-90 | 227: MH-91 | 0.003 | 24 | PVC | 0.013 | 11.48 | 6.36 | FALSE | 3.71 | 489.3 |
| CO-94 | 227: MH-91 | 229: MH-92 | 0.003 | 24 | PVC | 0.013 | 13.09 | 8.98 | FALSE | 4.19 | 309.4 |
| CO-95 | 229: MH-92 | 231: MH-93 | 0.001 | 24 | PVC | 0.013 | 7.81 | 9.06 | FALSE | 3.6 | 400 |
| CO-96 | 231: MH-93 | 233: MH-94 | 0.002 | 24 | PVC | 0.013 | 11.24 | 9.14 | FALSE | 3.81 | 400 |
| CO-97 | 233: MH-94 | 235: MH-95 | 0.001 | 24 | PVC | 0.013 | 8 | 9.21 | FALSE | 3.4 | 400 |
| CO-98 | 235: MH-95 | 237: MH-96 | 0.001 | 24 | PVC | 0.013 | 8 | 9.29 | FALSE | 3.59 | 400 |
| CO-99 | 237: MH-96 | 239: MH-97 | 0.001 | 30 | PVC | 0.013 | 11.55 | 9.36 | FALSE | 3.44 | 400 |
| CO-100 | 239: MH-97 | 691: OF-1 | 0.015 | 30 | PVC | 0.013 | 50.38 | 9.42 | FALSE | 7.85 | 244.1 |
| CO-121 | 282: MH-117 | 284: MH-118 | -0.001 | 24 | PVC | 0.013 | 7.15 | 4.22 | FALSE | 2.73 | 400 |
| CO-122 | 284: MH-118 | 286: MH-119 | -0.001 | 24 | PVC | 0.013 | 8 | 4.16 | FALSE | 2.68 | 400 |
| CO-123 | 286: MH-119 | 288: MH-120 | -0.002 | 24 | PVC | 0.013 | 8.87 | 4.09 | FALSE | 2.82 | 400 |
| CO-124 | 288: MH-120 | 290: MH-121 | -0.002 | 24 | PVC | 0.013 | 10.64 | 4.03 | FALSE | 3.15 | 400 |
| CO-125 | 290: MH-121 | 292: MH-122 | -0.004 | 24 | PVC | 0.013 | 14.27 | 3.96 | FALSE | 3.86 | 400 |
| CO-126 | 292: MH-122 | 294: MH-123 | -0.004 | 24 | PVC | 0.013 | 15.08 | 3.89 | FALSE | 4 | 400 |
| CO-127 | 294: MH-123 | 296: MH-124 | -0.004 | 24 | PVC | 0.013 | 14.39 | 3.83 | FALSE | 3.85 | 400 |
| CO-128 | 296: MH-124 | 298: MH-125 | -0.006 | 24 | PVC | 0.013 | 17.38 | 3.76 | FALSE | 4.39 | 401.1 |
| CO-129 | 298: MH-125 | 300: MH-126 | -0.013 | 18 | PVC | 0.013 | 12.11 | 3.7 | FALSE | 5.98 | 198.9 |
| CO-130 | 300: MH-126 | 302: MH-127 | -0.007 | 18 | PVC | 0.013 | 8.78 | 3.62 | FALSE | 4.7 | 393.5 |
| CO-131 | 302: MH-127 | 304: MH-128 | -0.006 | 18 | PVC | 0.013 | 8.06 | 3.54 | FALSE | 4.38 | 400 |
| CO-132 | 304: MH-128 | 306: MH-129 | -0.005 | 18 | PVC | 0.013 | 7.19 | 3.46 | FALSE | 4 | 400 |
| CO-133 | 306: MH-129 | 308: MH-130 | -0.004 | 18 | PVC | 0.013 | 6.55 | 3.38 | FALSE | 3.72 | 400 |
| CO-134 | 308: MH-130 | 310: MH-131 | -0.005 | 18 | PVC | 0.013 | 7.7 | 3.31 | FALSE | 4.16 | 400 |
| CO-135 | 310: MH-131 | 312: MH-132 | -0.008 | 18 | PVC | 0.013 | 9.1 | 3.23 | FALSE | 4.68 | 400 |
| CO-136 | 312: MH-132 | 314: MH-133 | -0.008 | 18 | PVC | 0.013 | 9.61 | 3.15 | FALSE | 4.83 | 485.4 |
| CO-137 | 314: MH-133 | 316: MH-134 | -0.013 | 18 | PVC | 0.013 | 11.93 | 3.07 | FALSE | 5.61 | 400 |
| CO-138 | 316: MH-134 | 318: MH-135 | -0.016 | 18 | PVC | 0.013 | 13.16 | 3 | FALSE | 5.98 | 400 |
| CO-139 | 318: MH-135 | 320: MH-136 | -0.017 | 18 | PVC | 0.013 | 13.88 | 2.92 | FALSE | 6.17 | 400 |
| CO-140 | 320: MH-136 | 322: MH-137 | -0.052 | 18 | PVC | 0.013 | 23.85 | 2.84 | FALSE | 9.06 | 54.8 |
| CO-142 | 324: MH-138 | 326: MH-139 | -0.015 | 8 | PVC | 0.013 | 1.46 | 0 | FALSE | 0 | 400 |
| CO-143 | 326: MH-139 | 328: MH-140 | -0.011 | 8 | PVC | 0.013 | 1.26 | 0 | FALSE | 0 | 400 |
| CO-144 | 328: MH-140 | 330: MH-141 | -0.014 | 8 | PVC | 0.013 | 1.41 | 0 | FALSE | 0 | 400 |
| CO-145 | 330: MH-141 | 332: MH-142 | -0.018 | 8 | PVC | 0.013 | 1.64 | 0 | FALSE | 0 | 400 |
| CO-146 | 332: MH-142 | 334: MH-143 | -0.019 | 8 | PVC | 0.013 | 1.66 | 0 | FALSE | 0 | 400 |
| CO-147 | 334: MH-143 | 336: MH-144 | -0.032 | 8 | PVC | 0.013 | 2.16 | 0 | FALSE | 0 | 400 |
| CO-148 | 336: MH-144 | 338: MH-145 | -0.021 | 8 | PVC | 0.013 | 1.73 | 0 | FALSE | 0 | 400 |
| CO-149 | 338: MH-145 | 340: MH-146 | -0.028 | 8 | PVC | 0.013 | 2.01 | 0 | FALSE | 0 | 400 |
| CO-151 | 342: MH-147 | 344: MH-148 | 0.002 | 8 | PVC | 0.013 | 0.51 | 0.09 | FALSE | 1.07 | 400 |
| CO-153 | 346: MH-149 | 348: MH-150 | 0.001 | 8 | PVC | 0.013 | 0.47 | 0.39 | FALSE | 1.39 | 400 |
| CO-154 | 348: MH-150 | 350: MH-151 | 0.003 | 18 | PVC | 0.013 | 5.75 | 2.02 | FALSE | 2.94 | 400 |
| CO-155 | 350: MH-151 | 352: MH-152 | 0.003 | 18 | PVC | 0.013 | 5.75 | 2.12 | FALSE | 2.98 | 400 |
| CO-156 | 352: MH-152 | 354: MH-153 | 0.003 | 18 | PVC | 0.013 | 5.75 | 2.21 | FALSE | 3.02 | 400 |
| CO-157 | 354: MH-153 | 356: MH-154 | 0.003 | 18 | PVC | 0.013 | 5.75 | 2.31 | FALSE | 3.05 | 400 |
| CO-158 | 356: MH-154 | 358: MH-155 | 0.003 | 18 | PVC | 0.013 | 5.75 | 2.4 | FALSE | 3.09 | 400 |
| CO-159 | 187: MH-71 | 360: MH-156 | -0.033 | 15 | PVC | 0.013 | 11.76 | 1.37 | FALSE | 6.34 | 400 |
| CO-160 | 360: MH-156 | 362: MH-157 | -0.005 | 15 | PVC | 0.013 | 4.37 | 1.36 | FALSE | 3.09 | 400 |
| CO-161 | 362: MH-157 | 364: MH-158 | -0.004 | 15 | PVC | 0.013 | 4.12 | 1.3 | FALSE | 2.92 | 394 |
| CO-162 | 364: MH-158 | 366: MH-159 | -0.004 | 15 | PVC | 0.013 | 4.11 | 1.25 | FALSE | 2.88 | 394.3 |
| CO-163 | 366: MH-159 | 368: MH-160 | -0.005 | 15 | PVC | 0.013 | 4.41 | 1.19 | FALSE | 2.99 | 342.9 |
| CO-164 | 368: MH-160 | 370: MH-161 | -0.125 | 8 | PVC | 0.013 | 4.28 | 0.9 | FALSE | 9.32 | 149.1 |

Pole Canyon Development - Conduit Analysis

| Label | Start-node Id | Stop-node Id | Constructed Slope (ft/ft) | Diameter (in) | Material | Manning's (n) | Full Capacity (ft ³ /s) | Maximum Flow (ft ³ /s) | Ever Overflowing/Surcharged? | Maximum Velocity (ft/s) | Length |
|--------|---------------|--------------|---------------------------|---------------|----------|---------------|------------------------------------|-----------------------------------|------------------------------|-------------------------|--------|
| CO-165 | 370: MH-161 | 372: MH-162 | -0.038 | 8 | PVC | 0.013 | 2.37 | 0.85 | FALSE | 6.03 | 400 |
| CO-166 | 372: MH-162 | 374: MH-163 | -0.044 | 8 | PVC | 0.013 | 2.54 | 0.79 | FALSE | 6.22 | 395.7 |
| CO-167 | 374: MH-163 | 376: MH-164 | -0.035 | 8 | PVC | 0.013 | 2.26 | 0.73 | FALSE | 5.59 | 400 |
| CO-168 | 376: MH-164 | 378: MH-165 | -0.033 | 8 | PVC | 0.013 | 2.18 | 0.7 | FALSE | 5.38 | 400 |
| CO-169 | 378: MH-165 | 380: MH-166 | -0.033 | 8 | PVC | 0.013 | 2.19 | 0.67 | FALSE | 5.41 | 400 |
| CO-170 | 380: MH-166 | 382: MH-167 | -0.042 | 8 | PVC | 0.013 | 2.49 | 0.64 | FALSE | 5.9 | 172.3 |
| CO-171 | 382: MH-167 | 384: MH-168 | -0.048 | 8 | PVC | 0.013 | 2.64 | 0.61 | FALSE | 6.05 | 124.4 |
| CO-172 | 384: MH-168 | 386: MH-169 | -0.046 | 8 | PVC | 0.013 | 2.6 | 0.42 | FALSE | 5.28 | 160.4 |
| CO-173 | 386: MH-169 | 388: MH-170 | -0.05 | 8 | PVC | 0.013 | 2.7 | 0.39 | FALSE | 5.29 | 400 |
| CO-174 | 388: MH-170 | 390: MH-171 | -0.05 | 8 | PVC | 0.013 | 2.71 | 0.36 | FALSE | 5.14 | 400 |
| CO-175 | 390: MH-171 | 392: MH-172 | -0.054 | 8 | PVC | 0.013 | 2.81 | 0.33 | FALSE | 5.13 | 400 |
| CO-176 | 392: MH-172 | 394: MH-173 | -0.054 | 8 | PVC | 0.013 | 2.8 | 0.26 | FALSE | 4.73 | 400 |
| CO-177 | 394: MH-173 | 396: MH-174 | -0.045 | 8 | PVC | 0.013 | 2.58 | 0.2 | FALSE | 4.1 | 400 |
| CO-178 | 396: MH-174 | 398: MH-175 | -0.028 | 8 | PVC | 0.013 | 2.03 | 0.13 | FALSE | 3.37 | 400 |
| CO-179 | 398: MH-175 | 400: MH-176 | -0.057 | 8 | PVC | 0.013 | 2.88 | 0.07 | FALSE | 1.85 | 151.5 |
| CO-186 | 418: MH-185 | 510: MH-231 | 0.031 | 8 | PVC | 0.013 | 2.14 | 0.24 | FALSE | 3.77 | 129.1 |
| CO-187 | 414: MH-183 | 416: MH-184 | 0.018 | 8 | PVC | 0.013 | 1.6 | 0.07 | FALSE | 2.18 | 400 |
| CO-188 | 416: MH-184 | 418: MH-185 | 0.013 | 8 | PVC | 0.013 | 1.35 | 0.13 | FALSE | 2.28 | 200 |
| CO-189 | 384: MH-168 | 420: MH-186 | -0.016 | 8 | PVC | 0.013 | 1.51 | 0.17 | FALSE | 2.56 | 400 |
| CO-190 | 420: MH-186 | 422: MH-187 | -0.004 | 8 | PVC | 0.013 | 0.76 | 0.14 | FALSE | 1.5 | 400 |
| CO-191 | 422: MH-187 | 424: MH-188 | -0.004 | 8 | PVC | 0.013 | 0.76 | 0.11 | FALSE | 1.46 | 400 |
| CO-192 | 424: MH-188 | 426: MH-189 | -0.004 | 8 | PVC | 0.013 | 0.76 | 0.07 | FALSE | 1.45 | 400 |
| CO-193 | 426: MH-189 | 428: MH-190 | -0.004 | 8 | PVC | 0.013 | 0.76 | 0.04 | FALSE | 1.62 | 150 |
| CO-194 | 368: MH-160 | 430: MH-191 | -0.009 | 8 | PVC | 0.013 | 1.17 | 0.23 | FALSE | 2.38 | 171.8 |
| CO-195 | 430: MH-191 | 432: MH-192 | -0.006 | 8 | PVC | 0.013 | 0.95 | 0.18 | FALSE | 1.81 | 260.5 |
| CO-196 | 432: MH-192 | 434: MH-193 | -0.004 | 8 | PVC | 0.013 | 0.76 | 0.12 | FALSE | 1.46 | 400 |
| CO-197 | 434: MH-193 | 436: MH-194 | -0.004 | 8 | PVC | 0.013 | 0.75 | 0.06 | FALSE | 1.63 | 205.8 |
| CO-199 | 438: MH-195 | 440: MH-196 | -0.02 | 18 | PVC | 0.013 | 14.89 | 2.76 | FALSE | 6.39 | 400 |
| CO-200 | 440: MH-196 | 442: MH-197 | -0.025 | 18 | PVC | 0.013 | 16.57 | 2.77 | FALSE | 6.91 | 400 |
| CO-201 | 442: MH-197 | 444: MH-198 | -0.019 | 18 | PVC | 0.013 | 14.6 | 2.77 | FALSE | 6.31 | 400 |
| CO-202 | 444: MH-198 | 446: MH-199 | -0.019 | 18 | PVC | 0.013 | 14.59 | 2.77 | FALSE | 6.3 | 400 |
| CO-203 | 446: MH-199 | 448: MH-200 | -0.019 | 18 | PVC | 0.013 | 14.3 | 2.77 | FALSE | 6.21 | 400 |
| CO-204 | 448: MH-200 | 450: MH-201 | -0.018 | 18 | PVC | 0.013 | 14.15 | 2.77 | FALSE | 6.17 | 400 |
| CO-205 | 450: MH-201 | 452: MH-202 | -0.021 | 18 | PVC | 0.013 | 15.27 | 2.69 | FALSE | 6.45 | 406.6 |
| CO-206 | 452: MH-202 | 454: MH-203 | -0.025 | 18 | PVC | 0.013 | 16.58 | 2.61 | FALSE | 6.78 | 389.4 |
| CO-207 | 454: MH-203 | 456: MH-204 | -0.003 | 18 | PVC | 0.013 | 5.48 | 2.53 | FALSE | 3.03 | 400 |
| CO-208 | 456: MH-204 | 458: MH-205 | -0.027 | 18 | PVC | 0.013 | 17.28 | 2.45 | FALSE | 5.47 | 400 |
| CO-209 | 458: MH-205 | 460: MH-206 | -0.012 | 18 | PVC | 0.013 | 11.39 | 2.37 | FALSE | 5.03 | 400 |
| CO-210 | 460: MH-206 | 462: MH-207 | -0.004 | 18 | PVC | 0.013 | 6.64 | 2.29 | FALSE | 3.37 | 400 |
| CO-212 | 464: MH-208 | 466: MH-209 | -0.034 | 15 | PVC | 0.013 | 11.88 | 1.78 | FALSE | 6.87 | 400 |
| CO-213 | 466: MH-209 | 468: MH-210 | -0.033 | 15 | PVC | 0.013 | 11.73 | 1.7 | FALSE | 6.72 | 400 |
| CO-214 | 468: MH-210 | 470: MH-211 | -0.021 | 15 | PVC | 0.013 | 9.38 | 1.62 | FALSE | 5.63 | 400 |
| CO-215 | 470: MH-211 | 472: MH-212 | -0.021 | 15 | PVC | 0.013 | 9.34 | 1.58 | FALSE | 5.57 | 400 |
| CO-216 | 472: MH-212 | 474: MH-213 | -0.036 | 15 | PVC | 0.013 | 12.24 | 1.54 | FALSE | 6.71 | 400 |
| CO-217 | 474: MH-213 | 476: MH-214 | -0.023 | 15 | PVC | 0.013 | 9.85 | 1.49 | FALSE | 5.69 | 400 |
| CO-218 | 476: MH-214 | 478: MH-215 | -0.004 | 15 | PVC | 0.013 | 4.05 | 1.45 | FALSE | 2.98 | 228.5 |
| CO-221 | 482: MH-217 | 484: MH-218 | -0.052 | 8 | PVC | 0.013 | 2.75 | 0.88 | FALSE | 6.95 | 400 |
| CO-222 | 484: MH-218 | 486: MH-219 | -0.055 | 8 | PVC | 0.013 | 2.83 | 0.84 | FALSE | 6.97 | 400 |
| CO-223 | 486: MH-219 | 488: MH-220 | -0.043 | 8 | PVC | 0.013 | 2.5 | 0.8 | FALSE | 6.27 | 400 |
| CO-224 | 488: MH-220 | 490: MH-221 | -0.041 | 8 | PVC | 0.013 | 2.43 | 0.69 | FALSE | 5.87 | 400 |
| CO-225 | 490: MH-221 | 492: MH-222 | -0.039 | 8 | PVC | 0.013 | 2.37 | 0.58 | FALSE | 5.46 | 147.1 |
| CO-233 | 492: MH-222 | 508: MH-230 | -0.046 | 8 | PVC | 0.013 | 2.6 | 0.47 | FALSE | 5.43 | 400 |
| CO-234 | 508: MH-230 | 510: MH-231 | -0.039 | 8 | PVC | 0.013 | 2.4 | 0.36 | FALSE | 4.66 | 400 |
| CO-235 | 478: MH-215 | 512: MH-232 | -0.004 | 8 | PVC | 0.013 | 0.77 | 0.25 | FALSE | 1.8 | 343.2 |
| CO-236 | 512: MH-232 | 514: MH-233 | -0.004 | 8 | PVC | 0.013 | 0.76 | 0.21 | FALSE | 1.68 | 400 |
| CO-237 | 514: MH-233 | 516: MH-234 | -0.004 | 8 | PVC | 0.013 | 0.76 | 0.17 | FALSE | 1.54 | 400 |
| CO-238 | 516: MH-234 | 518: MH-235 | -0.004 | 8 | PVC | 0.013 | 0.76 | 0.13 | FALSE | 1.49 | 400 |
| CO-239 | 518: MH-235 | 520: MH-236 | -0.004 | 8 | PVC | 0.013 | 0.76 | 0.09 | FALSE | 1.46 | 400 |
| CO-240 | 520: MH-236 | 522: MH-237 | -0.004 | 8 | PVC | 0.013 | 0.75 | 0.04 | FALSE | 1.62 | 155.8 |
| CO-246 | 462: MH-207 | 536: MH-245 | -0.005 | 18 | PVC | 0.013 | 7.24 | 2.2 | FALSE | 3.58 | 63.3 |
| CO-247 | 536: MH-245 | 464: MH-208 | -0.09 | 15 | PVC | 0.013 | 19.4 | 1.87 | FALSE | 9.97 | 193.3 |

Pole Canyon Development - Conduit Analysis

| Label | Start-node Id | Stop-node Id | Constructed Slope (ft/ft) | Diameter (in) | Material | Manning's (n) | Full Capacity (ft ³ /s) | Maximum Flow (ft ³ /s) | Ever Overflowing/Surcharged? | Maximum Velocity (ft/s) | Length |
|--------|---------------|--------------|---------------------------|---------------|----------|---------------|------------------------------------|-----------------------------------|------------------------------|-------------------------|--------|
| CO-248 | 536: MH-245 | 541: MH-246 | -0.004 | 8 | PVC | 0.013 | 0.76 | 0.26 | FALSE | 1.8 | 400 |
| CO-249 | 541: MH-246 | 543: MH-247 | -0.004 | 8 | PVC | 0.013 | 0.76 | 0.17 | FALSE | 1.55 | 400 |
| CO-250 | 543: MH-247 | 545: MH-248 | -0.004 | 8 | PVC | 0.013 | 0.78 | 0.09 | FALSE | 1.38 | 312.9 |
| CO-251 | 478: MH-215 | 547: MH-249 | -0.09 | 12 | PVC | 0.013 | 10.69 | 1.17 | FALSE | 8.97 | 122.1 |
| CO-253 | 547: MH-249 | 552: MH-250 | -0.004 | 8 | PVC | 0.013 | 0.77 | 0.21 | FALSE | 1.68 | 368.3 |
| CO-254 | 552: MH-250 | 554: MH-251 | -0.004 | 8 | PVC | 0.013 | 0.76 | 0.17 | FALSE | 1.54 | 400 |
| CO-255 | 554: MH-251 | 556: MH-252 | -0.004 | 8 | PVC | 0.013 | 0.76 | 0.13 | FALSE | 1.48 | 400 |
| CO-256 | 556: MH-252 | 558: MH-253 | -0.005 | 8 | PVC | 0.013 | 0.84 | 0.09 | FALSE | 1.58 | 400 |
| CO-257 | 558: MH-253 | 560: MH-254 | -0.028 | 8 | PVC | 0.013 | 2.03 | 0.04 | FALSE | 1.42 | 265.2 |
| CO-258 | 217: MH-86 | 562: MH-255 | -0.003 | 15 | PVC | 0.013 | 3.73 | 1.3 | FALSE | 2.61 | 400 |
| CO-259 | 562: MH-255 | 564: MH-256 | -0.003 | 15 | PVC | 0.013 | 3.73 | 1.22 | FALSE | 2.67 | 400 |
| CO-260 | 564: MH-256 | 566: MH-257 | -0.003 | 15 | PVC | 0.013 | 3.73 | 1.14 | FALSE | 2.61 | 400 |
| CO-261 | 566: MH-257 | 568: MH-258 | -0.003 | 15 | PVC | 0.013 | 3.73 | 1.06 | FALSE | 2.56 | 400 |
| CO-262 | 568: MH-258 | 570: MH-259 | -0.003 | 12 | PVC | 0.013 | 2.02 | 0.98 | FALSE | 2.49 | 400 |
| CO-263 | 570: MH-259 | 572: MH-260 | -0.003 | 12 | PVC | 0.013 | 2.1 | 0.9 | FALSE | 2.5 | 400 |
| CO-264 | 572: MH-260 | 574: MH-261 | -0.002 | 12 | PVC | 0.013 | 1.78 | 0.73 | FALSE | 2.08 | 538 |
| CO-265 | 574: MH-261 | 576: MH-262 | -0.003 | 12 | PVC | 0.013 | 1.89 | 0.55 | FALSE | 1.99 | 474.4 |
| CO-266 | 576: MH-262 | 578: MH-263 | -0.004 | 12 | PVC | 0.013 | 2.18 | 0.37 | FALSE | 1.93 | 358.3 |
| CO-267 | 578: MH-263 | 580: MH-264 | -0.003 | 8 | PVC | 0.013 | 0.7 | 0.18 | FALSE | 1.48 | 403.6 |
| CO-268 | 691: OF-1 | 582: MH-265 | -0.01 | 24 | PVC | 0.013 | 23.05 | 2 | FALSE | 4.45 | 400.2 |
| CO-269 | 582: MH-265 | 584: MH-266 | -0.001 | 18 | PVC | 0.013 | 3.15 | 1.92 | FALSE | 2.11 | 400 |
| CO-270 | 584: MH-266 | 586: MH-267 | -0.001 | 18 | PVC | 0.013 | 3.07 | 1.85 | FALSE | 1.95 | 400 |
| CO-271 | 586: MH-267 | 588: MH-268 | -0.001 | 18 | PVC | 0.013 | 3.04 | 1.78 | FALSE | 1.9 | 400 |
| CO-272 | 588: MH-268 | 590: MH-269 | -0.001 | 18 | PVC | 0.013 | 3.34 | 1.71 | FALSE | 1.95 | 400 |
| CO-273 | 590: MH-269 | 592: MH-270 | -0.001 | 18 | PVC | 0.013 | 2.71 | 1.64 | FALSE | 1.8 | 400 |
| CO-274 | 592: MH-270 | 594: MH-271 | -0.002 | 18 | PVC | 0.013 | 4.2 | 1.56 | FALSE | 2.13 | 400 |
| CO-275 | 594: MH-271 | 596: MH-272 | -0.004 | 18 | PVC | 0.013 | 6.43 | 1.49 | FALSE | 2.91 | 400 |
| CO-276 | 596: MH-272 | 598: MH-273 | -0.002 | 12 | PVC | 0.013 | 1.66 | 1.42 | FALSE | 2.41 | 400 |
| CO-277 | 598: MH-273 | 600: MH-274 | -0.003 | 12 | PVC | 0.013 | 1.89 | 1.35 | FALSE | 2.57 | 400 |
| CO-278 | 600: MH-274 | 602: MH-275 | -0.005 | 12 | PVC | 0.013 | 2.41 | 1.28 | FALSE | 3.04 | 400 |
| CO-279 | 602: MH-275 | 604: MH-276 | -0.007 | 12 | PVC | 0.013 | 2.91 | 1.2 | FALSE | 3.45 | 400 |
| CO-280 | 604: MH-276 | 606: MH-277 | -0.004 | 12 | PVC | 0.013 | 2.16 | 1.13 | FALSE | 2.72 | 400 |
| CO-281 | 606: MH-277 | 608: MH-278 | -0.005 | 12 | PVC | 0.013 | 2.42 | 1.06 | FALSE | 2.91 | 296.9 |
| CO-282 | 608: MH-278 | 610: MH-279 | -0.003 | 12 | PVC | 0.013 | 2.06 | 0.99 | FALSE | 2.53 | 400 |
| CO-283 | 610: MH-279 | 612: MH-280 | -0.003 | 12 | PVC | 0.013 | 2.06 | 0.91 | FALSE | 2.47 | 400 |
| CO-284 | 612: MH-280 | 614: MH-281 | -0.003 | 12 | PVC | 0.013 | 2.05 | 0.84 | FALSE | 2.41 | 400 |
| CO-285 | 614: MH-281 | 616: MH-282 | -0.003 | 12 | PVC | 0.013 | 2.07 | 0.76 | FALSE | 2.35 | 400 |
| CO-286 | 616: MH-282 | 618: MH-283 | -0.003 | 12 | PVC | 0.013 | 2.06 | 0.69 | FALSE | 2.28 | 400 |
| CO-287 | 618: MH-283 | 620: MH-284 | -0.003 | 12 | PVC | 0.013 | 2.06 | 0.62 | FALSE | 2.21 | 400 |
| CO-288 | 620: MH-284 | 622: MH-285 | -0.003 | 12 | PVC | 0.013 | 2.06 | 0.55 | FALSE | 2.12 | 400 |
| CO-289 | 622: MH-285 | 624: MH-286 | -0.003 | 12 | PVC | 0.013 | 2.06 | 0.37 | FALSE | 1.86 | 400 |
| CO-290 | 624: MH-286 | 626: MH-287 | -0.003 | 12 | PVC | 0.013 | 2.06 | 0.18 | FALSE | 1.44 | 400 |
| CO-291 | 547: MH-249 | 482: MH-217 | -0.049 | 8 | PVC | 0.013 | 2.68 | 0.93 | FALSE | 6.65 | 301.4 |
| CO-292 | 181: MH-68 | 631: MH-288 | 0.042 | 8 | PVC | 0.013 | 2.49 | 0.47 | FALSE | 5.22 | 286.5 |
| CO-293 | 631: MH-288 | 183: MH-69 | 0.003 | 18 | PVC | 0.013 | 6.16 | 0.59 | FALSE | 2.12 | 113.5 |
| CO-294 | 51: MH-12 | 631: MH-288 | 0.029 | 12 | PVC | 0.013 | 6.05 | 0.12 | FALSE | 1.47 | 58.5 |

Pole Canyon Development - Manhole Analysis

| Label | Ground Elevation (ft) | Rim Elevation (ft) | Invert Elevation (ft) | Diameter (ft) | Hydraulic Grade (ft) | Is Flooded Ever? | Maximum Overflow (ft ³ /s) |
|-------|-----------------------|--------------------|-----------------------|---------------|----------------------|------------------|---------------------------------------|
| MH-7 | 4,923.60 | 4,923.60 | 4,915.60 | 3 | 4,915.60 | FALSE | 0 |
| MH-8 | 4,924.20 | 4,924.20 | 4,916.20 | 3 | 4,916.50 | FALSE | 0 |
| MH-10 | 4,889.00 | 4,889.00 | 4,879.40 | 3 | 4,879.40 | FALSE | 0 |
| MH-12 | 5,008.60 | 5,008.60 | 4,995.60 | 3 | 4,995.60 | FALSE | 0 |
| MH-14 | 5,017.30 | 5,017.30 | 5,003.50 | 3 | 5,003.50 | FALSE | 0 |
| MH-15 | 5,024.50 | 5,024.50 | 5,010.10 | 3 | 5,010.20 | FALSE | 0 |
| MH-16 | 5,040.70 | 5,040.70 | 5,023.70 | 3 | 5,023.70 | FALSE | 0 |
| MH-17 | 5,051.70 | 5,051.70 | 5,038.10 | 3 | 5,038.10 | FALSE | 0 |
| MH-18 | 5,062.40 | 5,062.40 | 5,047.10 | 3 | 5,047.10 | FALSE | 0 |
| MH-19 | 5,073.00 | 5,073.00 | 5,057.90 | 3 | 5,057.90 | FALSE | 0 |
| MH-20 | 5,080.70 | 5,080.70 | 5,065.40 | 3 | 5,065.40 | FALSE | 0 |
| MH-21 | 5,032.10 | 5,032.10 | 5,017.80 | 3 | 5,017.80 | FALSE | 0 |
| MH-22 | 5,038.50 | 5,038.50 | 5,024.90 | 3 | 5,024.90 | FALSE | 0 |
| MH-23 | 5,042.00 | 5,042.00 | 5,029.10 | 3 | 5,029.10 | FALSE | 0 |
| MH-24 | 5,051.10 | 5,051.10 | 5,032.00 | 3 | 5,032.00 | FALSE | 0 |
| MH-25 | 5,051.30 | 5,051.30 | 5,035.40 | 3 | 5,035.40 | FALSE | 0 |
| MH-26 | 5,056.00 | 5,056.00 | 5,040.40 | 3 | 5,040.40 | FALSE | 0 |
| MH-27 | 5,061.20 | 5,061.20 | 5,043.40 | 3 | 5,043.40 | FALSE | 0 |
| MH-28 | 5,087.40 | 5,087.40 | 5,072.50 | 3 | 5,072.50 | FALSE | 0 |
| MH-29 | 5,078.20 | 5,078.20 | 5,063.10 | 3 | 5,063.10 | FALSE | 0 |
| MH-30 | 5,065.00 | 5,065.00 | 5,043.30 | 3 | 5,043.30 | FALSE | 0 |
| MH-31 | 5,047.20 | 5,047.20 | 5,033.50 | 3 | 5,033.50 | FALSE | 0 |
| MH-33 | 5,082.00 | 5,082.00 | 5,069.00 | 3 | 5,069.00 | FALSE | 0 |
| MH-35 | 5,059.00 | 5,059.00 | 5,045.50 | 3 | 5,045.50 | FALSE | 0 |
| MH-36 | 5,042.90 | 5,042.90 | 5,030.50 | 3 | 5,030.50 | FALSE | 0 |
| MH-39 | 5,072.60 | 5,072.60 | 5,059.00 | 3 | 5,059.00 | FALSE | 0 |
| MH-40 | 5,061.00 | 5,061.00 | 5,047.30 | 3 | 5,047.30 | FALSE | 0 |
| MH-41 | 5,073.70 | 5,073.70 | 5,058.20 | 3 | 5,058.20 | FALSE | 0 |
| MH-44 | 5,090.30 | 5,090.30 | 5,078.60 | 3 | 5,078.50 | FALSE | 0 |
| MH-45 | 5,086.80 | 5,086.80 | 5,072.60 | 3 | 5,072.50 | FALSE | 0 |
| MH-46 | 5,082.00 | 5,082.00 | 5,071.00 | 3 | 5,071.00 | FALSE | 0 |
| MH-47 | 5,070.90 | 5,070.90 | 5,059.30 | 3 | 5,059.30 | FALSE | 0 |
| MH-48 | 5,067.10 | 5,067.10 | 5,053.30 | 3 | 5,053.30 | FALSE | 0 |
| MH-49 | 5,078.00 | 5,078.00 | 5,065.00 | 3 | 5,065.00 | FALSE | 0 |
| MH-54 | 5,101.10 | 5,101.10 | 5,093.10 | 3 | 5,093.10 | FALSE | 0 |
| MH-55 | 5,119.60 | 5,119.60 | 5,111.60 | 3 | 5,111.60 | FALSE | 0 |
| MH-56 | 5,125.50 | 5,125.50 | 5,117.50 | 3 | 5,117.50 | FALSE | 0 |
| MH-57 | 5,123.60 | 5,123.60 | 5,115.60 | 3 | 5,115.60 | FALSE | 0 |
| MH-58 | 5,116.20 | 5,116.20 | 5,108.20 | 3 | 5,108.20 | FALSE | 0 |
| MH-59 | 5,101.90 | 5,101.90 | 5,093.90 | 3 | 5,093.90 | FALSE | 0 |
| MH-60 | 5,086.00 | 5,086.00 | 5,078.00 | 3 | 5,078.10 | FALSE | 0 |
| MH-61 | 5,074.60 | 5,074.60 | 5,066.60 | 3 | 5,066.70 | FALSE | 0 |
| MH-62 | 5,057.30 | 5,057.30 | 5,049.30 | 3 | 5,049.40 | FALSE | 0 |
| MH-63 | 5,050.00 | 5,050.00 | 5,042.00 | 3 | 5,042.20 | FALSE | 0 |

Pole Canyon Development - Manhole Analysis

| Label | Ground Elevation (ft) | Rim Elevation (ft) | Invert Elevation (ft) | Diameter (ft) | Hydraulic Grade (ft) | Is Flooded Ever? | Maximum Overflow (ft ² /s) |
|--------|-----------------------|--------------------|-----------------------|---------------|----------------------|------------------|---------------------------------------|
| MH-64 | 5,046.00 | 5,046.00 | 5,038.00 | 3 | 5,038.20 | FALSE | 0 |
| MH-65 | 5,038.40 | 5,038.40 | 5,030.40 | 3 | 5,030.60 | FALSE | 0 |
| MH-66 | 5,032.00 | 5,032.00 | 5,024.00 | 3 | 5,024.20 | FALSE | 0 |
| MH-67 | 5,024.00 | 5,024.00 | 5,016.00 | 3 | 5,016.10 | FALSE | 0 |
| MH-68 | 5,014.10 | 5,014.10 | 5,006.10 | 3 | 5,006.20 | FALSE | 0 |
| MH-69 | 5,004.00 | 5,004.00 | 4,993.50 | 3 | 4,993.70 | FALSE | 0 |
| MH-70 | 4,997.60 | 4,997.60 | 4,989.60 | 3 | 4,989.70 | FALSE | 0 |
| MH-71 | 4,992.30 | 4,992.30 | 4,984.30 | 3 | 4,984.50 | FALSE | 0 |
| MH-72 | 4,980.50 | 4,980.50 | 4,972.50 | 3 | 4,972.70 | FALSE | 0 |
| MH-73 | 4,969.50 | 4,969.50 | 4,961.50 | 3 | 4,961.70 | FALSE | 0 |
| MH-74 | 4,956.70 | 4,956.70 | 4,948.70 | 3 | 4,948.90 | FALSE | 0 |
| MH-75 | 4,945.20 | 4,945.20 | 4,937.20 | 3 | 4,937.50 | FALSE | 0 |
| MH-76 | 4,933.00 | 4,933.00 | 4,925.00 | 3 | 4,925.20 | FALSE | 0 |
| MH-77 | 4,922.90 | 4,922.90 | 4,914.90 | 3 | 4,915.20 | FALSE | 0 |
| MH-78 | 4,913.50 | 4,913.50 | 4,905.50 | 3 | 4,905.80 | FALSE | 0 |
| MH-79 | 4,906.10 | 4,906.10 | 4,898.10 | 3 | 4,898.40 | FALSE | 0 |
| MH-80 | 4,898.80 | 4,898.80 | 4,890.80 | 3 | 4,891.10 | FALSE | 0 |
| MH-81 | 4,892.20 | 4,892.20 | 4,884.20 | 3 | 4,884.60 | FALSE | 0 |
| MH-82 | 4,887.70 | 4,887.70 | 4,879.70 | 3 | 4,880.10 | FALSE | 0 |
| MH-83 | 4,884.20 | 4,884.20 | 4,876.20 | 3 | 4,876.60 | FALSE | 0 |
| MH-84 | 4,881.20 | 4,881.20 | 4,873.20 | 3 | 4,873.60 | FALSE | 0 |
| MH-85 | 4,878.60 | 4,878.60 | 4,870.60 | 3 | 4,870.90 | FALSE | 0 |
| MH-86 | 4,877.40 | 4,877.40 | 4,865.60 | 3 | 4,866.20 | FALSE | 0 |
| MH-87 | 4,876.00 | 4,876.00 | 4,864.40 | 3 | 4,865.00 | FALSE | 0 |
| MH-88 | 4,873.80 | 4,873.80 | 4,863.20 | 3 | 4,863.80 | FALSE | 0 |
| MH-89 | 4,870.00 | 4,870.00 | 4,862.00 | 3 | 4,862.60 | FALSE | 0 |
| MH-90 | 4,868.80 | 4,868.80 | 4,860.80 | 3 | 4,861.40 | FALSE | 0 |
| MH-91 | 4,867.50 | 4,867.50 | 4,859.50 | 3 | 4,860.30 | FALSE | 0 |
| MH-92 | 4,866.50 | 4,866.50 | 4,858.50 | 3 | 4,859.50 | FALSE | 0 |
| MH-93 | 4,866.00 | 4,866.00 | 4,858.00 | 3 | 4,858.80 | FALSE | 0 |
| MH-94 | 4,864.80 | 4,864.80 | 4,857.00 | 3 | 4,858.00 | FALSE | 0 |
| MH-95 | 4,864.20 | 4,864.20 | 4,856.50 | 3 | 4,857.50 | FALSE | 0 |
| MH-96 | 4,864.00 | 4,864.00 | 4,856.00 | 3 | 4,857.10 | FALSE | 0 |
| MH-97 | 4,863.70 | 4,863.70 | 4,855.70 | 3 | 4,856.20 | FALSE | 0 |
| MH-117 | 4,861.00 | 4,861.00 | 4,853.60 | 3 | 4,854.00 | FALSE | 0 |
| MH-118 | 4,862.00 | 4,862.00 | 4,854.00 | 3 | 4,854.60 | FALSE | 0 |
| MH-119 | 4,862.20 | 4,862.20 | 4,854.50 | 3 | 4,855.10 | FALSE | 0 |
| MH-120 | 4,863.10 | 4,863.10 | 4,855.10 | 3 | 4,855.70 | FALSE | 0 |
| MH-121 | 4,864.00 | 4,864.00 | 4,856.00 | 3 | 4,856.50 | FALSE | 0 |
| MH-122 | 4,865.60 | 4,865.60 | 4,857.60 | 3 | 4,858.00 | FALSE | 0 |
| MH-123 | 4,867.40 | 4,867.40 | 4,859.40 | 3 | 4,859.80 | FALSE | 0 |
| MH-124 | 4,869.00 | 4,869.00 | 4,861.00 | 3 | 4,861.40 | FALSE | 0 |
| MH-125 | 4,871.40 | 4,871.40 | 4,863.40 | 3 | 4,863.70 | FALSE | 0 |
| MH-126 | 4,874.00 | 4,874.00 | 4,866.00 | 3 | 4,866.30 | FALSE | 0 |

Pole Canyon Development - Manhole Analysis

| Label | Ground Elevation (ft) | Rim Elevation (ft) | Invert Elevation (ft) | Diameter (ft) | Hydraulic Grade (ft) | Is Flooded Ever? | Maximum Overflow (ft ³ /s) |
|--------|-----------------------|--------------------|-----------------------|---------------|----------------------|------------------|---------------------------------------|
| MH-127 | 4,876.80 | 4,876.80 | 4,868.80 | 3 | 4,869.10 | FALSE | 0 |
| MH-128 | 4,879.10 | 4,879.10 | 4,871.10 | 3 | 4,871.50 | FALSE | 0 |
| MH-129 | 4,881.00 | 4,881.00 | 4,873.00 | 3 | 4,873.40 | FALSE | 0 |
| MH-130 | 4,882.50 | 4,882.50 | 4,874.50 | 3 | 4,875.00 | FALSE | 0 |
| MH-131 | 4,884.70 | 4,884.70 | 4,876.70 | 3 | 4,877.10 | FALSE | 0 |
| MH-132 | 4,887.70 | 4,887.70 | 4,879.70 | 3 | 4,880.10 | FALSE | 0 |
| MH-133 | 4,891.80 | 4,891.80 | 4,883.80 | 3 | 4,884.10 | FALSE | 0 |
| MH-134 | 4,896.90 | 4,896.90 | 4,888.90 | 3 | 4,889.20 | FALSE | 0 |
| MH-135 | 4,903.20 | 4,903.20 | 4,895.20 | 3 | 4,895.50 | FALSE | 0 |
| MH-136 | 4,910.20 | 4,910.20 | 4,902.20 | 3 | 4,902.50 | FALSE | 0 |
| MH-137 | 4,915.00 | 4,915.00 | 4,905.00 | 3 | 4,905.20 | FALSE | 0 |
| MH-138 | 4,925.80 | 4,925.80 | 4,917.80 | 3 | 4,917.80 | FALSE | 0 |
| MH-139 | 4,931.60 | 4,931.60 | 4,923.60 | 3 | 4,923.60 | FALSE | 0 |
| MH-140 | 4,936.00 | 4,936.00 | 4,928.00 | 3 | 4,928.00 | FALSE | 0 |
| MH-141 | 4,941.50 | 4,941.50 | 4,933.50 | 3 | 4,933.50 | FALSE | 0 |
| MH-142 | 4,948.80 | 4,948.80 | 4,940.80 | 3 | 4,940.80 | FALSE | 0 |
| MH-143 | 4,956.30 | 4,956.30 | 4,948.30 | 3 | 4,948.30 | FALSE | 0 |
| MH-144 | 4,969.20 | 4,969.20 | 4,961.20 | 3 | 4,961.20 | FALSE | 0 |
| MH-145 | 4,977.40 | 4,977.40 | 4,969.40 | 3 | 4,969.40 | FALSE | 0 |
| MH-146 | 4,988.50 | 4,988.50 | 4,980.50 | 3 | 4,980.50 | FALSE | 0 |
| MH-147 | 4,872.10 | 4,872.10 | 4,868.70 | 3 | 4,868.70 | FALSE | 0 |
| MH-148 | 4,873.30 | 4,873.30 | 4,868.00 | 3 | 4,868.20 | FALSE | 0 |
| MH-149 | 4,873.80 | 4,873.80 | 4,867.30 | 3 | 4,867.60 | FALSE | 0 |
| MH-150 | 4,872.90 | 4,872.90 | 4,866.70 | 3 | 4,867.30 | FALSE | 0 |
| MH-151 | 4,872.00 | 4,872.00 | 4,865.50 | 3 | 4,866.10 | FALSE | 0 |
| MH-152 | 4,871.10 | 4,871.10 | 4,864.30 | 3 | 4,864.90 | FALSE | 0 |
| MH-153 | 4,870.20 | 4,870.20 | 4,863.10 | 3 | 4,863.70 | FALSE | 0 |
| MH-154 | 4,869.30 | 4,869.30 | 4,861.90 | 3 | 4,862.50 | FALSE | 0 |
| MH-155 | 4,868.40 | 4,868.40 | 4,860.70 | 3 | 4,861.30 | FALSE | 0 |
| MH-156 | 5,005.60 | 5,005.60 | 4,997.60 | 3 | 4,997.70 | FALSE | 0 |
| MH-157 | 5,014.10 | 5,014.10 | 4,999.40 | 3 | 4,999.70 | FALSE | 0 |
| MH-158 | 5,024.00 | 5,024.00 | 5,001.00 | 3 | 5,001.30 | FALSE | 0 |
| MH-159 | 5,028.10 | 5,028.10 | 5,002.60 | 3 | 5,002.90 | FALSE | 0 |
| MH-160 | 5,027.60 | 5,027.60 | 5,004.20 | 3 | 5,004.50 | FALSE | 0 |
| MH-161 | 5,030.90 | 5,030.90 | 5,022.90 | 3 | 5,023.00 | FALSE | 0 |
| MH-162 | 5,046.30 | 5,046.30 | 5,038.30 | 3 | 5,038.40 | FALSE | 0 |
| MH-163 | 5,063.80 | 5,063.80 | 5,055.80 | 3 | 5,055.90 | FALSE | 0 |
| MH-164 | 5,077.80 | 5,077.80 | 5,069.80 | 3 | 5,070.00 | FALSE | 0 |
| MH-165 | 5,090.90 | 5,090.90 | 5,082.90 | 3 | 5,083.00 | FALSE | 0 |
| MH-166 | 5,104.00 | 5,104.00 | 5,096.00 | 3 | 5,096.20 | FALSE | 0 |
| MH-167 | 5,111.30 | 5,111.30 | 5,103.30 | 3 | 5,103.50 | FALSE | 0 |
| MH-168 | 5,117.30 | 5,117.30 | 5,109.30 | 3 | 5,109.40 | FALSE | 0 |
| MH-169 | 5,124.70 | 5,124.70 | 5,116.70 | 3 | 5,116.80 | FALSE | 0 |
| MH-170 | 5,144.70 | 5,144.70 | 5,136.70 | 3 | 5,136.80 | FALSE | 0 |

Pole Canyon Development - Manhole Analysis

| Label | Ground Elevation (ft) | Rim Elevation (ft) | Invert Elevation (ft) | Diameter (ft) | Hydraulic Grade (ft) | Is Flooded Ever? | Maximum Overflow (ft ³ /s) |
|--------|-----------------------|--------------------|-----------------------|---------------|----------------------|------------------|---------------------------------------|
| MH-171 | 5,164.80 | 5,164.80 | 5,156.80 | 3 | 5,156.90 | FALSE | 0 |
| MH-172 | 5,186.50 | 5,186.50 | 5,178.50 | 3 | 5,178.60 | FALSE | 0 |
| MH-173 | 5,207.90 | 5,207.90 | 5,199.90 | 3 | 5,200.00 | FALSE | 0 |
| MH-174 | 5,226.10 | 5,226.10 | 5,218.10 | 3 | 5,218.10 | FALSE | 0 |
| MH-175 | 5,237.40 | 5,237.40 | 5,229.40 | 3 | 5,229.40 | FALSE | 0 |
| MH-176 | 5,246.00 | 5,246.00 | 5,238.00 | 3 | 5,238.00 | FALSE | 0 |
| MH-183 | 5,253.50 | 5,253.50 | 5,245.50 | 3 | 5,245.50 | FALSE | 0 |
| MH-184 | 5,246.50 | 5,246.50 | 5,238.50 | 3 | 5,238.50 | FALSE | 0 |
| MH-185 | 5,244.00 | 5,244.00 | 5,236.00 | 3 | 5,236.10 | FALSE | 0 |
| MH-186 | 5,129.70 | 5,129.70 | 5,115.50 | 3 | 5,115.50 | FALSE | 0 |
| MH-187 | 5,136.90 | 5,136.90 | 5,117.10 | 3 | 5,117.10 | FALSE | 0 |
| MH-188 | 5,136.20 | 5,136.20 | 5,118.70 | 3 | 5,118.70 | FALSE | 0 |
| MH-189 | 5,130.10 | 5,130.10 | 5,120.30 | 3 | 5,120.30 | FALSE | 0 |
| MH-190 | 5,125.90 | 5,125.90 | 5,120.90 | 3 | 5,120.90 | FALSE | 0 |
| MH-191 | 5,023.20 | 5,023.20 | 5,005.80 | 3 | 5,005.90 | FALSE | 0 |
| MH-192 | 5,022.50 | 5,022.50 | 5,007.40 | 3 | 5,007.40 | FALSE | 0 |
| MH-193 | 5,014.60 | 5,014.60 | 5,009.00 | 3 | 5,009.00 | FALSE | 0 |
| MH-194 | 5,013.80 | 5,013.80 | 5,009.80 | 3 | 5,009.80 | FALSE | 0 |
| MH-195 | 4,927.80 | 4,927.80 | 4,919.80 | 3 | 4,920.10 | FALSE | 0 |
| MH-196 | 4,935.80 | 4,935.80 | 4,927.80 | 3 | 4,928.10 | FALSE | 0 |
| MH-197 | 4,945.80 | 4,945.80 | 4,937.80 | 3 | 4,938.00 | FALSE | 0 |
| MH-198 | 4,953.50 | 4,953.50 | 4,945.50 | 3 | 4,945.80 | FALSE | 0 |
| MH-199 | 4,961.20 | 4,961.20 | 4,953.20 | 3 | 4,953.50 | FALSE | 0 |
| MH-200 | 4,968.60 | 4,968.60 | 4,960.60 | 3 | 4,960.90 | FALSE | 0 |
| MH-201 | 4,975.90 | 4,975.90 | 4,967.90 | 3 | 4,968.20 | FALSE | 0 |
| MH-202 | 4,984.50 | 4,984.50 | 4,976.50 | 3 | 4,976.70 | FALSE | 0 |
| MH-203 | 4,994.20 | 4,994.20 | 4,986.20 | 3 | 4,986.40 | FALSE | 0 |
| MH-204 | 4,995.30 | 4,995.30 | 4,987.30 | 3 | 4,987.70 | FALSE | 0 |
| MH-205 | 5,006.10 | 5,006.10 | 4,998.10 | 3 | 4,998.30 | FALSE | 0 |
| MH-206 | 5,015.10 | 5,015.10 | 5,002.80 | 3 | 5,003.10 | FALSE | 0 |
| MH-207 | 5,023.00 | 5,023.00 | 5,004.40 | 3 | 5,004.80 | FALSE | 0 |
| MH-208 | 5,030.10 | 5,030.10 | 5,022.10 | 3 | 5,022.30 | FALSE | 0 |
| MH-209 | 5,043.60 | 5,043.60 | 5,035.60 | 3 | 5,035.80 | FALSE | 0 |
| MH-210 | 5,056.80 | 5,056.80 | 5,048.80 | 3 | 5,049.00 | FALSE | 0 |
| MH-211 | 5,065.30 | 5,065.30 | 5,057.30 | 3 | 5,057.50 | FALSE | 0 |
| MH-212 | 5,073.60 | 5,073.60 | 5,065.60 | 3 | 5,065.80 | FALSE | 0 |
| MH-213 | 5,088.00 | 5,088.00 | 5,080.00 | 3 | 5,080.20 | FALSE | 0 |
| MH-214 | 5,100.30 | 5,100.30 | 5,089.30 | 3 | 5,089.50 | FALSE | 0 |
| MH-215 | 5,108.70 | 5,108.70 | 5,090.20 | 3 | 5,090.50 | FALSE | 0 |
| MH-217 | 5,124.00 | 5,124.00 | 5,116.00 | 3 | 5,116.20 | FALSE | 0 |
| MH-218 | 5,144.70 | 5,144.70 | 5,136.70 | 3 | 5,136.90 | FALSE | 0 |
| MH-219 | 5,166.70 | 5,166.70 | 5,158.70 | 3 | 5,158.80 | FALSE | 0 |
| MH-220 | 5,183.80 | 5,183.80 | 5,175.80 | 3 | 5,175.90 | FALSE | 0 |
| MH-221 | 5,200.00 | 5,200.00 | 5,192.00 | 3 | 5,192.20 | FALSE | 0 |

Pole Canyon Development - Manhole Analysis

| Label | Ground Elevation (ft) | Rim Elevation (ft) | Invert Elevation (ft) | Diameter (ft) | Hydraulic Grade (ft) | Is Flooded Ever? | Maximum Overflow (ft ³ /s) |
|--------|-----------------------|--------------------|-----------------------|---------------|----------------------|------------------|---------------------------------------|
| MH-222 | 5,205.70 | 5,205.70 | 5,197.70 | 3 | 5,197.80 | FALSE | 0 |
| MH-230 | 5,224.20 | 5,224.20 | 5,216.20 | 3 | 5,216.30 | FALSE | 0 |
| MH-231 | 5,239.90 | 5,239.90 | 5,231.90 | 3 | 5,232.10 | FALSE | 0 |
| MH-232 | 5,117.20 | 5,117.20 | 5,091.60 | 3 | 5,091.80 | FALSE | 0 |
| MH-233 | 5,125.00 | 5,125.00 | 5,093.20 | 3 | 5,093.40 | FALSE | 0 |
| MH-234 | 5,127.60 | 5,127.60 | 5,094.80 | 3 | 5,094.80 | FALSE | 0 |
| MH-235 | 5,123.60 | 5,123.60 | 5,096.40 | 3 | 5,096.40 | FALSE | 0 |
| MH-236 | 5,109.80 | 5,109.80 | 5,098.00 | 3 | 5,098.00 | FALSE | 0 |
| MH-237 | 5,102.60 | 5,102.60 | 5,098.60 | 3 | 5,098.60 | FALSE | 0 |
| MH-245 | 5,024.10 | 5,024.10 | 5,004.70 | 3 | 5,005.00 | FALSE | 0 |
| MH-246 | 5,021.30 | 5,021.30 | 5,006.30 | 3 | 5,006.50 | FALSE | 0 |
| MH-247 | 5,016.30 | 5,016.30 | 5,007.90 | 3 | 5,007.90 | FALSE | 0 |
| MH-248 | 5,013.20 | 5,013.20 | 5,009.20 | 3 | 5,009.20 | FALSE | 0 |
| MH-249 | 5,113.40 | 5,113.40 | 5,101.20 | 3 | 5,101.30 | FALSE | 0 |
| MH-250 | 5,113.10 | 5,113.10 | 5,102.70 | 3 | 5,102.90 | FALSE | 0 |
| MH-251 | 5,110.80 | 5,110.80 | 5,104.30 | 3 | 5,104.30 | FALSE | 0 |
| MH-252 | 5,112.40 | 5,112.40 | 5,105.90 | 3 | 5,105.90 | FALSE | 0 |
| MH-253 | 5,115.80 | 5,115.80 | 5,107.80 | 3 | 5,107.80 | FALSE | 0 |
| MH-254 | 5,123.30 | 5,123.30 | 5,115.30 | 3 | 5,115.30 | FALSE | 0 |
| MH-255 | 4,877.30 | 4,877.30 | 4,866.90 | 3 | 4,867.20 | FALSE | 0 |
| MH-256 | 4,877.40 | 4,877.40 | 4,868.30 | 3 | 4,868.60 | FALSE | 0 |
| MH-257 | 4,878.30 | 4,878.30 | 4,869.60 | 3 | 4,869.90 | FALSE | 0 |
| MH-258 | 4,879.40 | 4,879.40 | 4,870.90 | 3 | 4,871.20 | FALSE | 0 |
| MH-259 | 4,880.00 | 4,880.00 | 4,872.20 | 3 | 4,872.50 | FALSE | 0 |
| MH-260 | 4,880.10 | 4,880.10 | 4,873.60 | 3 | 4,873.90 | FALSE | 0 |
| MH-261 | 4,881.80 | 4,881.80 | 4,875.00 | 3 | 4,875.20 | FALSE | 0 |
| MH-262 | 4,883.10 | 4,883.10 | 4,876.30 | 3 | 4,876.50 | FALSE | 0 |
| MH-263 | 4,885.10 | 4,885.10 | 4,877.60 | 3 | 4,877.80 | FALSE | 0 |
| MH-264 | 4,887.20 | 4,887.20 | 4,879.00 | 3 | 4,879.00 | FALSE | 0 |
| MH-265 | 4,864.20 | 4,864.20 | 4,856.20 | 3 | 4,856.40 | FALSE | 0 |
| MH-266 | 4,864.50 | 4,864.50 | 4,856.50 | 3 | 4,857.00 | FALSE | 0 |
| MH-267 | 4,864.90 | 4,864.90 | 4,856.90 | 3 | 4,857.30 | FALSE | 0 |
| MH-268 | 4,865.20 | 4,865.20 | 4,857.20 | 3 | 4,857.70 | FALSE | 0 |
| MH-269 | 4,865.60 | 4,865.60 | 4,857.60 | 3 | 4,858.00 | FALSE | 0 |
| MH-270 | 4,865.90 | 4,865.90 | 4,857.90 | 3 | 4,858.30 | FALSE | 0 |
| MH-271 | 4,866.00 | 4,866.00 | 4,858.50 | 3 | 4,858.90 | FALSE | 0 |
| MH-272 | 4,868.00 | 4,868.00 | 4,860.00 | 3 | 4,860.30 | FALSE | 0 |
| MH-273 | 4,868.90 | 4,868.90 | 4,860.90 | 3 | 4,861.30 | FALSE | 0 |
| MH-274 | 4,870.00 | 4,870.00 | 4,862.00 | 3 | 4,862.40 | FALSE | 0 |
| MH-275 | 4,871.80 | 4,871.80 | 4,863.80 | 3 | 4,864.10 | FALSE | 0 |
| MH-276 | 4,874.50 | 4,874.50 | 4,866.50 | 3 | 4,866.80 | FALSE | 0 |
| MH-277 | 4,876.00 | 4,876.00 | 4,868.00 | 3 | 4,868.30 | FALSE | 0 |
| MH-278 | 4,877.10 | 4,877.10 | 4,869.30 | 3 | 4,869.60 | FALSE | 0 |
| MH-279 | 4,878.00 | 4,878.00 | 4,870.70 | 3 | 4,871.00 | FALSE | 0 |

Pole Canyon Development - Manhole Analysis

| Label | Ground Elevation (ft) | Rim Elevation (ft) | Invert Elevation (ft) | Diameter (ft) | Hydraulic Grade (ft) | Is Flooded Ever? | Maximum Overflow (ft ³ /s) |
|--------|-----------------------|--------------------|-----------------------|---------------|----------------------|------------------|---------------------------------------|
| MH-280 | 4,878.70 | 4,878.70 | 4,872.00 | 3 | 4,872.30 | FALSE | 0 |
| MH-281 | 4,880.00 | 4,880.00 | 4,873.30 | 3 | 4,873.60 | FALSE | 0 |
| MH-282 | 4,880.30 | 4,880.30 | 4,874.70 | 3 | 4,874.90 | FALSE | 0 |
| MH-283 | 4,882.00 | 4,882.00 | 4,876.00 | 3 | 4,876.30 | FALSE | 0 |
| MH-284 | 4,882.00 | 4,882.00 | 4,877.40 | 3 | 4,877.60 | FALSE | 0 |
| MH-285 | 4,883.60 | 4,883.60 | 4,878.70 | 3 | 4,878.90 | FALSE | 0 |
| MH-286 | 4,884.30 | 4,884.30 | 4,880.00 | 3 | 4,880.20 | FALSE | 0 |
| MH-287 | 4,885.60 | 4,885.60 | 4,881.40 | 3 | 4,881.40 | FALSE | 0 |



| Color Coding Legend | |
|-----------------------|--------|
| Conduit Diameter (in) | Color |
| 6 | Green |
| 8 | Blue |
| 10 | Purple |
| 12 | Yellow |
| 15 | Black |
| 18 | Black |
| 24 | Black |
| 30 | Black |
| 36 | Black |
| 42 | Black |
| 48 | Black |
| 60 | Black |
| 72 | Black |
| 84 | Black |
| 96 | Black |
| 108 | Black |
| 120 | Black |
| 144 | Black |
| 168 | Black |
| 192 | Black |
| 216 | Black |
| 240 | Black |
| 264 | Black |
| Other | Black |

Exhibit 6 – Dry Utility Master Plan

ELECTRIC LOAD/INFRASTRUCTURE DETAILS

POLE CANYON DEVELOPMENT

Parcels Inside of Development Agreement Boundary

Neighborhood Planning Areas (NPA)*

| Planning Area | Planning Area Type | Acres | Animals | Overall Density | Total Units (ERU) | Estimated kW Electric Load (12.47 kV) | 12.47 kV Main Feeder | Ckt 1 Load (kW) | Ckt 2 Load (kW) | Ckt 3 Load (kW) | Ckt 4 Load (kW) | Ckt 5 Load (kW) | Ckt 6, 7, 8 Load (kW) |
|-------------------|--------------------|--------------|---------|-----------------|-------------------|---------------------------------------|----------------------|-----------------|-----------------|-----------------|-----------------|-----------------|-----------------------|
| 1 | Residential | 108.73 | No | 4 | 435 | 1,522 | Ckt 1 | 1,522 | | | | | |
| 2 | Residential | 121.72 | No | 4 | 487 | 1,704 | Ckt 3 | | | 1,704 | | | |
| 3 | Residential | 226.57 | No | 4 | 906 | 3,172 | Ckt 2 | | 3,172 | | | | |
| 4 | Residential | 87.27 | No | 4 | 349 | 1,222 | Ckt 2 | | 1,222 | | | | |
| 5 | Residential | 207.2 | Mixed | 4 | 829 | 2,901 | Ckt 2 | | 2,901 | | | | |
| 6 | Residential | 158.74 | No | 4 | 635 | 2,222 | Ckt 1 | 2,222 | | | | | |
| 7 | Residential | 231.79 | No | 4 | 927 | 3,245 | Ckt 1 | 3,245 | | | | | |
| 8 | Residential | 261.09 | No | 4 | 1,044 | 3,655 | Ckt 4 | | | | 3,655 | | |
| 9 | Residential | 245.46 | Yes | 4 | 982 | 3,436 | Ckt 5 | | | | | 3,436 | |
| 10 | Residential | 153.48 | Yes | 4 | 614 | 2,149 | Ckt 5 | | | | | 2,149 | |
| 11 | Residential | 211.81 | Yes | 4 | 847 | 2,965 | Ckt 4 | | | | 2,965 | | |
| 12 | Oquirrh View | 7.06 | No | 2.83 | 20 | 70 | Ckt 5 | | | | | 70 | |
| Sub Totals | | 2,021 | | | 8,075 | 28,264 | | 6,990 | 7,295 | 1,704 | 6,621 | 5,655 | 0 |

* Electric usage = 3.5 kW/ERU

Mixed-use Planning Area (MUPA)*

| | | | | | | | | | | | | | |
|---|-----------|-------|----|----|-----|-------|-------|---|---|-------|---|---|---|
| 1 | Mixed Use | 65.09 | No | 12 | 781 | 2,734 | Ckt 3 | 0 | 0 | 2,734 | 0 | 0 | 0 |
|---|-----------|-------|----|----|-----|-------|-------|---|---|-------|---|---|---|

* Electric usage = 3.5 kW/ERU

Commercial Planning Areas (CPA)*

| | | | | | | | | | | | | | |
|-------------------|---------------------|---------------|-----|-----|------------|--------------|-------|----------|----------|--------------|----------|----------|----------|
| 1 | Wilson Commercial | 5.5± | n/a | n/a | 44 | 138 | Ckt 3 | | | 138 | | | |
| 2 | Commercial / Retail | 8.0± | n/a | n/a | 63 | 200 | Ckt 3 | | | 200 | | | |
| 3 | Commercial / Retail | 63.29 | n/a | n/a | 502 | 1,582 | Ckt 3 | | | 1,582 | | | |
| Sub Totals | | 76.79± | | | 609 | 1,920 | | 0 | 0 | 1,920 | 0 | 0 | 0 |

* Electric usage = 25 kW/Acre

Business Park Planning Areas (BPA)*

| | | | | | | | | | | | | | |
|-------------------|---------------|------------|-----|-----|--------------|---------------|-------------|----------|----------|----------|----------|----------|---------------|
| 1 | Business Park | 179.12 | n/a | n/a | 2,843 | 8,956 | Ckt 6, 7, 8 | | | | | | 7,442 |
| 2 | Business Park | 140.77 | n/a | n/a | 2,234 | 7,039 | Ckt 6, 7, 8 | | | | | | 7,442 |
| 3 | Business Park | 127.61 | n/a | n/a | 2,026 | 6,381 | Ckt 6, 7, 8 | | | | | | 7,442 |
| 4 | Business Park | 147.87 | n/a | n/a | 2,347 | 7,394 | Ckt 6, 7, 8 | | | | | | 7,442 |
| Sub Totals | | 595 | | | 9,450 | 29,769 | | 0 | 0 | 0 | 0 | 0 | 29,769 |

* Electric Usage = 50 kW/Acre

| | | | | | | | | |
|-------------------------------|--------|--------|-------|-------|-------|-------|-------|--------|
| Total ERUs/Electric Load (kW) | 18,916 | 62,686 | 6,990 | 7,295 | 6,358 | 6,621 | 5,655 | 29,769 |
| Total Acres | 2,758 | | | | | | | |
| Gross Densities | 6.86 | 22.73 | | | | | | |

Parcels Outside of Development Agreement Boundary

| Area | Land Use/Owner | Acres | Density | Total Units (ERU) | Estimated Electric Load (kW) |
|------|-----------------------------|--------|---------|-------------------|------------------------------|
| A | White Hills Subdivision | 47.45 | 2.4236 | 115 | 403 |
| B | Cook Parcels | 12.82 | TBD | TBD | TBD |
| C | White Hills Country Estates | 63.52 | 0.1732 | 11 | 39 |
| D | MMN, LLC | 6.8 | TBD | TBD | TBD |
| E | White Parcels | 14.81± | TBD | TBD | TBD |
| F | 2B Investments, LLC | 48.14 | TBD | TBD | TBD |
| G | Jody B. Brown Trust | 10.02 | TBD | TBD | TBD |
| H | White Hills SSD | 24.9 | TBD | TBD | TBD |
| I | Bowles Property | 83.61 | TBD | TBD | TBD |

DRY UTILITY INFRASTRUCTURE COST SUMMARY POLE CANYON DEVELOPMENT

Phase 1 Development – 4,400 ERUs

ELECTRIC INFRASTRUCTURE

| | |
|----------------------------------------------------------------------------|-----------------|
| 138 kV Transmission Line With Double Circuit Underbuild - Drawing No. E102 | \$ 5,320,277.35 |
| 12.47 kV Underground Main Feeders - Drawing No. E104 | \$ 1,973,859.32 |

NATURAL GAS INFRASTRUCTURE

| | |
|---------------------------------------------|-----------------|
| High Pressure Gas System - Drawing No. G102 | \$ 1,026,282.31 |
| Low Pressure Gas System - Drawing No. G103 | \$ 306,536.94 |

| | |
|------------|-----------------|
| Total Cost | \$ 8,626,955.92 |
| \$/ERU | \$ 1,960.67 |

Phase 2 Development – 7,750 ERUs

ELECTRIC INFRASTRUCTURE

| | |
|----------------------------------------------------------------------------|-----------------|
| 138 kV Transmission Line With Double Circuit Underbuild - Drawing No. E102 | \$ 5,320,277.35 |
| 138 - 12.47Y/7.2 kV 60 MVA Substation - Drawing No. E103 | \$ 5,106,124.26 |
| 12.47 kV Underground Main Feeders - Drawing No. E101 | \$ 5,151,156.93 |

NATURAL GAS INFRASTRUCTURE

| | |
|---------------------------------------------|-----------------|
| High Pressure Gas System - Drawing No. G102 | \$ 1,026,282.31 |
| Low Pressure Gas System - Drawing No. G101 | \$ 1,466,115.32 |

| | |
|------------|-----------------|
| Total Cost | \$18,069,956.17 |
| \$/ERU | \$ 2,331.60 |

Build Out – 15,500 ERUs

ELECTRIC INFRASTRUCTURE

| | |
|----------------------------------------------------------------------------|-----------------|
| 138 kV Transmission Line With Double Circuit Underbuild - Drawing No. E102 | \$ 5,320,277.35 |
| 138 - 12.47Y/7.2 kV 60 MVA Substation - Drawing No. E103 | \$ 5,106,124.26 |
| 12.47 kV Underground Main Feeders - Drawing No. E101 | \$ 5,151,156.93 |
| 30 MVA 138 - 12.47Y/7.2 kV Transformer Addition - Drawing No. E103 | \$ 2,540,673.65 |

NATURAL GAS INFRASTRUCTURE

| | |
|---------------------------------------------|-----------------|
| High Pressure Gas System - Drawing No. G102 | \$ 1,026,282.31 |
| Low Pressure Gas System - Drawing No. G101 | \$ 1,466,115.32 |

| | |
|------------|-----------------|
| Total Cost | \$20,610,629.82 |
| \$/ERU | \$ 1,329.72 |

CLARIFICATIONS

The following general clarifications are applicable to the cost estimates for the electric and natural gas infrastructure included elsewhere herein and the Dry Utility Infrastructure Cost Summary included on the previous page:

1. All costs are in 2008 dollars and are based on equipment and materials prices and labor costs as of July 2008. Prices for materials and equipment utilized in the construction of electric and natural gas infrastructure have shown significant volatility due to variation in crude oil and metals pricing. Contingencies have been included in the cost estimates to attempt to account for this volatility. It is not possible, however, to determine if these contingencies will be adequate to cover future equipment and materials price increases.
2. The 12.47 kV Underground Main Feeder Costs are for the main feeders (Including conduit, 750 kcmil Al. 15 kV URD cable, cable terminations and splices, manholes, 600 Amp sectionalizers and pad mounted switchgear) required to serve the Pole Canyon Development only. Additional electric infrastructure (Including but not limited to conduit, #2 AWG Al. 15 kV URD cable, cable terminations, 200 Amp sectionalizers, transformers, secondary cable and secondary junction boxes) and costs for this infrastructure will be required/incurred to serve the individual planning areas within the Pole Canyon Development and the individual facilities within these areas. The cost for this electric infrastructure can not be estimated until the arrangements of these areas and the infrastructure within the areas, and the type and magnitude of the electric usage for the facilities within the areas are known.
3. The Low Pressure Natural Gas Costs are for the main line low pressure gas piping (Including 6" and 4" polyethylene piping and fittings) required to serve the Pole Canyon Development only. Additional low pressure natural gas infrastructure (Including 4" and 2" polyethylene gas piping and fittings, and 3/4" and larger gas services) and costs for this infrastructure will be required/incurred to serve the individual planning areas within the Pole Canyon Development and the facilities within these areas. The cost for this low pressure gas infrastructure can not be estimated until the arrangements of these areas and the infrastructure within the areas, and the magnitude of the gas usage of the facilities within the areas are known.
4. The Phase 1 cost estimates for electric infrastructure assume that the City of Eagle Mountain will construct the South Substation, located at Bobby Wren Road and Lake Mountain Road, in a time frame that is consistent with the timing of the initial phase of the Pole Canyon Development. The cost of this substation is \$4,396,892.00. The Phase 1 cost estimate for the Pole Canyon Development includes three 15 kV Breakers to be installed in the Metal Clad Switchgear to be included in this substation.
5. Anticipated times from start of design to energization/pressurization (Design, material and equipment procurement, construction, and energization/pressurization) of the major electric and natural gas infrastructure required for Phase 1, Phase 2 and Build Out of the Pole Canyon Development are as follows:

138 - 12.47Y/7.2 kV 60 MVA South Substation - 15 Months

138 - 12.47Y/7.2 kV 60 MVA Pole Canyon Substation - 15 Months

30 MVA Transformer Addition to Pole Canyon Substation - 15 Months

138 kV Transmission Line with Double Circuit 12.47 kV Underbuild - 12 Months

6" Steel High Pressure Gas Line and Pressure Reduction Facilities - 9 Months

Anticipated times from start of engineering to energization/pressurization of the 138 kV Transmission Line with Double Circuit 12.47 kV Underbuild and 6" Steel High Pressure Gas Line and Pressure Reduction Facilities may be extended beyond the times shown above by the right of way acquisition process.

ELECTRIC INFRASTRUCTURE COSTS

POLE CANYON DEVELOPMENT

12.47 kV Underground Main Feeders

Drawing No. E101

| Item Designation | Item Description | Item Quantity | Item Units | Unit Material Cost | Unit Labor Hours | Unit Labor Cost* | Total Item Labor Hours | Total Item Cost |
|--------------------------------------------------------|----------------------------------------------------------------------------------------------------|---------------|------------|--------------------|------------------|------------------|------------------------|-----------------------|
| Misc | Bonding, Mobilization and Demobilization, Phasing, Testing and Energization | 1 | LS | | | | | \$186,189.41 |
| Cond | Direct Bureid 6" Schedule 40 PVC Conduit: | 70,445 | Feet | \$2.72 | 0.011 | \$0.83 | 774.90 | \$249,727.53 |
| Casing | Casing - 6" PVC Conduit at Road Crossings | 2,875 | Feet | \$6.50 | 0.018 | \$1.35 | 51.75 | \$22,568.75 |
| Cable | 750 kcmil Al 15 kV URD Cable With 220 Mils EPR Insulation, LLDPE Jacket and 1/3 Concentric Neutral | 208,725 | Feet | \$6.18 | 0.014 | \$1.05 | 2,922.15 | \$1,509,081.75 |
| Swgr | 15 kV Dead Front Pad Mounted Switchgear: | | | | | | | |
| | 1. PME9 Switchgear | 19 | Each | \$14,400.00 | 5 | \$375.00 | 95.00 | \$280,725.00 |
| | 2. PME11 Switchgear** | 8 | Each | \$15,260.00 | 5 | \$375.00 | 40.00 | \$125,080.00 |
| Sect | 15 kV 600 Amp Sectionalizer | 46 | Each | \$600.00 | 3 | \$225.00 | 138.00 | \$37,950.00 |
| Box Pad | 15 kV Switchgear and Sectionalizer Box Pads: | | | | | | | |
| | 1. PME9 Switchgear | 18 | Each | \$1,400.00 | 8 | \$600.00 | 144.00 | \$36,000.00 |
| | 2. PME11 Switchgear | 9 | Each | \$1,400.00 | 8 | \$600.00 | 72.00 | \$18,000.00 |
| | 3. 15 kV 600 Amp Sect | 38 | Each | \$288.00 | 6 | \$450.00 | 228.00 | \$28,044.00 |
| | 4. 15 kV 600 Amp Sect (Future Switchgear) | 8 | Each | \$1,845.00 | 8 | \$600.00 | 64.00 | \$19,560.00 |
| Jct | 15 kV, 600 Amp Non-Loadbreak Jct - 2 Way | 138 | Each | \$189.00 | 1 | \$75.00 | 138.00 | \$36,432.00 |
| Elbow | 15 kV, 600 Amp Non-Loadbreak Elbows with Test Points: | | | | | | | |
| | 1. Elbow with Stud (BOL-T) | 348 | Each | \$140.00 | 3 | \$225.00 | 1,044.00 | \$127,020.00 |
| | 2. Elbow with Insulating Cap (TOP-II) | 453 | Each | \$292.00 | 3 | \$225.00 | 1,359.00 | \$234,201.00 |
| | 3. Elbow Cold Shrink Seal | 801 | Each | \$10.65 | 0.25 | \$18.75 | 200.25 | \$23,549.40 |
| | 4. 15 kV, 200 Amp Insulating Cap | 132 | Each | \$35.00 | 0.25 | \$18.75 | 33.00 | \$7,095.00 |
| | 5. Connecting Plug - T Splices | 92 | Each | \$32.00 | 0.5 | \$37.50 | 46.00 | \$6,394.00 |
| Term | 15 kV Cold Shrink Cable Terminator | 24 | Each | \$110.00 | 3 | \$225.00 | 72.00 | \$8,040.00 |
| Manhole | Precast Concrete Manhole AASHTO H-20 Loading: | | | | | | | |
| | 1. 8' x 10' x 7' for Three 750 Al. Circuits | 6 | Each | \$15,000.00 | 16 | \$1,200.00 | 96.00 | \$97,200.00 |
| | 2. 6' x 6' x 6' - 6" for Two 750 AL. Circuits | 19 | Each | \$12,000.00 | 12 | \$900.00 | 228.00 | \$245,100.00 |
| Trench | Trench and Backfill for PVC Conduits for Electric Cables: | | | | | | | |
| | 1. Four Electric Conduits | 1,320 | Feet | | 0.135 | \$10.13 | 178.20 | \$13,365.00 |
| | 2. Two Electric Conduits | 11,690 | Feet | | 0.106 | \$7.95 | 1,239.14 | \$92,935.50 |
| | 3. One Electric Conduit | 41,785 | Feet | | 0.093 | \$6.98 | 3,886.01 | \$291,450.38 |
| Grnd | Equipment and Manhole Grounding: | | | | | | | |
| | 1. 15 kV Pad Mounted Switchgear | 27 | Each | \$150.00 | 3 | \$225.00 | 81.00 | \$10,125.00 |
| | 2. 15 kV 600 Amp Sectionalizer | 46 | Each | \$100.00 | 2 | \$150.00 | 92.00 | \$11,500.00 |
| | 3. Manhole | 25 | Each | \$250.00 | 6 | \$450.00 | 150.00 | \$17,500.00 |
| Label | Labeling of Cables In Equipment and Manholes: | | | | | | | |
| | 1. 15 kV Pad Mounted Switchgear | 27 | Each | \$125 | 2 | \$150.00 | 54.00 | \$7,425.00 |
| | 2. 15 kV 600 Amp Sectionalizer | 46 | Each | \$125.00 | 2 | \$150.00 | 92.00 | \$12,650.00 |
| | 3. Manhole | 25 | Each | \$250.00 | 3 | \$225.00 | 75.00 | \$11,875.00 |
| Fault | Three Phase Faulted Circuit Indicator for 15 kV Pad Mounted Switchgear | 30 | Each | \$225.00 | 0.20 | \$15.00 | 6.00 | \$7,200.00 |
| Equip | Large Equipment Costs | 1 | LS | | | | | \$135,993.90 |
| Cont | Construction Contingency (15%) | 1 | LS | | | | | \$586,496.64 |
| Electric Infrastructure Construction Sub Totals | | | | | | | 13,599 | \$4,496,474.25 |
| Engr | Engineering | 1 | LS | | | | | \$337,235.57 |
| City | Eagle Mountain City Costs | 1 | LS | | | | | \$67,447.11 |
| RMP | Buy Out Of RMP Electric Distribution Facilities | 1 | LS | | | | | \$250,000.00 |
| Total Electric Infrastructure Costs | | | | | | | | \$5,151,156.93 |

* Loaded labor rate of \$75.00/Hour which includes labor, 20% overtime, labor overheads, FICA, social security, supervision, small tools and expendables, small trucks and profit.

** Two PME11 15 kV Pad Mounted Switchgear installed in development substation for capacitor banks.

ELECTRIC INFRASTRUCTURE COSTS
POLE CANYON DEVELOPMENT
138 kV Transmission Line With Double Circuit Underbuild
Drawing No. E102

| Item Description | Item Quantity | Item Units | Unit Labor Hours | Unit Material Cost | Unit Labor Cost* | Total Item Labor Hours | Total Item Cost |
|---------------------------------------------------------------------------|---------------|------------|------------------|--------------------|------------------|------------------------|-----------------------|
| Mobilization/Demobilization & Bonding | 1 | LS | | | | | \$86,833.37 |
| Wood Poles | 1 | LS | 2268.03 | \$370,054.00 | \$170,102.00 | 2268.03 | \$540,156.00 |
| Steel Poles | 1 | LS | 330 | \$393,572.00 | \$24,750.00 | 330.00 | \$418,322.00 |
| Transmission Tangent PTA 2 1/2" | 1 | LS | 1410 | \$128,302.95 | \$105,750.00 | 1410.00 | \$234,052.95 |
| Transmission Tangent PTA 3" | 1 | LS | 0 | \$0.00 | \$0.00 | 0.00 | \$0.00 |
| Transmission DDE PTA | 1 | LS | 337.5 | \$11,291.55 | \$25,312.50 | 337.50 | \$36,604.05 |
| Distribution Tangent PTA | 1 | LS | 3525 | \$112,196.52 | \$264,375.00 | 3525.00 | \$376,571.52 |
| Distribution DDE PTA | 1 | LS | 675 | \$21,018.60 | \$50,625.00 | 675.00 | \$71,643.60 |
| 795 kcmil ACSR Transmission Conductor | 110,800 | Feet | 0.015 | \$2.03 | \$1.13 | 1662.00 | \$349,130.80 |
| 795 kcmil ACSR Distribution Conductor | 258,720 | Feet | 0.01097 | \$2.03 | \$1.13 | 2838.73 | \$817,555.20 |
| OPGW Shield Wire | 37,000 | Feet | 0.01069 | \$1.25 | \$0.80 | 395.69 | \$75,927.08 |
| OPGW Shield Wire Splices | 7 | Each | 40 | \$5,000.00 | \$3,000.00 | 280.00 | \$56,000.00 |
| Concrete Foundations | 1 | LS | 1201.43 | \$147,257.00 | \$90,107.00 | 1201.43 | \$237,364.00 |
| Wood Pole Grounds | 142 | Each | 0.61111 | \$44.00 | \$45.83 | 86.78 | \$12,756.33 |
| 12.47 kV OH/UG Riser Structures | 6 | Each | 65 | \$2,500.00 | \$4,875.00 | 390.00 | \$44,250.00 |
| Access Road Const/Maint | 1 | LS | 750 | | \$56,250.00 | 750.00 | \$56,250.00 |
| ROW Restoration/Seeding | 1 | LS | 350 | \$5,000.00 | \$26,250.00 | 350.00 | \$31,250.00 |
| Large Equipment Costs | 1 | LS | | | | | \$115,501.11 |
| Construction Contingency (15%) | 1 | LS | | | | | \$503,675.03 |
| 138 kV Transmission Line Construction Sub Totals | | | | | | 16,500 | \$4,063,843.05 |
| Engineering | | | | | | | \$304,788.23 |
| Eagle Mountain City Costs | | | | | | | \$101,596.08 |
| Right of Way Costs** | | | | | | | \$850,000.00 |
| Total 138 kV Transmission Line With Double Circuit Underbuild Cost | | | | | | | \$5,320,227.35 |

* Loaded labor rate of \$75.00/Hour which includes labor, 20% overtime, labor overheads, FICA, social security, supervision, small tools and expendables, small trucks and profit.

** Right of Way to be shared by 138 kV transmission line and 6" steel high pressure gas line in some areas.

ELECTRIC INFRASTRUCTURE COSTS

POLE CANYON DEVELOPMENT

60 MVA 138 - 12.47Y/7.2 kV Substation

Drawing No. E103

| Item Description | Item Qty | Item Units | Unit Material Cost | Unit Labor Hours | Unit Labor Cost* | Total Item Labor Hours | Total Item Cost |
|--------------------------------------------|----------|------------|--------------------|------------------|------------------|------------------------|-----------------------|
| Mobilization/Demobilization & Bonding | 1 | lot | | 200 | \$30,000.00 | 400 | \$30,000.00 |
| Substation Site: | | | | | | | |
| 1. Chain Link Fencing | 925 | feet | | | | | \$18,500.00 |
| 2. Grading, Site Roads & Rock Surfacing | 1 | lot | | | | | \$45,000.00 |
| 3. Grounding (fence, structures & grid) | 1 | lot | \$35,828.00 | 200 | \$15,000.00 | 200 | \$50,828.00 |
| Concrete Pads/Foundations: | | | | | | | |
| 1. Power Transformer (56 yds) | 2 | each | \$10,360.00 | 241 | \$18,075.00 | 482 | \$56,870.00 |
| 2. Metal-clad Gear (30 yds) | 1 | each | \$5,550.00 | 176 | \$13,200.00 | 176 | \$18,750.00 |
| 3. H-frame Structure (6'x22' = 23 yds) | 2 | each | \$4,255.00 | 100 | \$7,500.00 | 200 | \$23,510.00 |
| 4. 138 kV Switch Str (3'x11' = 3 yds) | 4 | each | \$555.00 | 13 | \$975.00 | 52 | \$6,120.00 |
| 5. 138 kV 1 Ph Bus Supt (2'x11' = 1.5 yds) | 12 | each | \$277.50 | 7 | \$525.00 | 84 | \$9,630.00 |
| 6. 15 kV 3 Ph Bus Supt (2x2'x11' = 3 yds) | 4 | each | \$555.00 | 14 | \$1,050.00 | 56 | \$6,420.00 |
| 7. 138 kV Breaker (3'x11' = 3 yds) | 2 | each | \$555.00 | 13 | \$975.00 | 26 | \$3,060.00 |
| 8. Static Mast (4'x15' = 7 yds) | 2 | each | \$1,295.00 | 31 | \$2,325.00 | 62 | \$7,240.00 |
| High Voltage Equipment: | | | | | | | |
| 1. LTC Power Transformer, 18/24/30 MVA | 2 | each | \$1,125,000.00 | 250 | \$18,750.00 | 500 | \$2,287,500.00 |
| 2. 15 kV Metal-clad Switchgear | 1 | lineup | \$715,000.00 | 200 | \$15,000.00 | 200 | \$730,000.00 |
| 3. 138 kV Breaker | 2 | each | \$75,000.00 | 40 | \$3,000.00 | 80 | \$156,000.00 |
| 4. 15 kV, 2.5 MVAR Pad Mounted Capacitor | 2 | each | \$67,000.00 | 45 | \$3,375.00 | 90 | \$140,750.00 |
| 5. 138 kV GOAB Switch | 4 | each | \$9,500.00 | 40 | \$3,000.00 | 160 | \$50,000.00 |
| 6. 138 kV Arrester | 3 | each | \$500.00 | 4 | \$300.00 | 12 | \$2,400.00 |
| Steel Structures: | | | | | | | |
| 1. H-frame Entrance | 1 | each | \$35,000.00 | 80 | \$6,000.00 | 80 | \$41,000.00 |
| 2. 138 kV Switch | 4 | each | \$2,100.00 | 30 | \$2,250.00 | 120 | \$17,400.00 |
| 3. 138 kV 1 Ph Bus Support | 12 | each | \$1,100.00 | 10 | \$750.00 | 120 | \$22,200.00 |
| 4. 15 kV 3 Ph Bus Support | 4 | each | \$4,500.00 | 30 | \$2,250.00 | 120 | \$27,000.00 |
| 5. Static Mast | 2 | each | \$15,000.00 | 10 | \$750.00 | 20 | \$31,500.00 |
| 6. Switching Platforms | 4 | each | \$450.00 | 2 | \$150.00 | 8 | \$2,400.00 |
| Bus Work (Strain & Rigid): | | | | | | | |
| 1. 138 kV (insulators, bus & fittings) | 1 | lot | \$30,000.00 | 145 | \$10,875.00 | 145 | \$40,875.00 |
| 2. 12.5 kV (insulators, bus & fittings) | 1 | lot | \$20,000.00 | 45 | \$3,375.00 | 45 | \$23,375.00 |
| Cable, Conduit & Low Voltage Terminations | | | | | | | |
| 1. 15 kV Cable (to switchgear - 6 x 100') | 600 | feet | \$30.00 | 0.036 | \$2.70 | 21.6 | \$19,620.00 |
| 2. 6" Conduit (to switchgear - 8 x 100') | 600 | feet | \$2.50 | 0.025 | \$1.88 | 15 | \$2,625.00 |
| 3. Relay & Control | 1 | lot | \$16,000.00 | 120 | \$9,000.00 | 120 | \$25,000.00 |
| 4. Low Voltage AC and DC | 1 | lot | \$12,000.00 | 180 | \$13,500.00 | 180 | \$25,500.00 |
| 5. Trench & Backfill | 1 | lot | \$5,000.00 | 100 | \$7,500.00 | 100 | \$12,500.00 |
| Miscellaneous: | | | | | | | |
| 1. Terminations, 15 kV URD Cable | 9 | each | \$120.00 | 4 | \$300.00 | 36 | \$3,780.00 |
| 2. Yard Lights, Switches & Outlets | 1 | lot | \$4,000.00 | 45 | \$3,375.00 | 45 | \$7,375.00 |
| 3. Transmission Conductor & Dead Ends | 500 | feet | \$2.00 | 0.040 | \$3.00 | 20 | \$2,500.00 |
| 4. Transmission Shield Wire & Dead Ends | 550 | feet | \$0.50 | 0.030 | \$2.25 | 16.5 | \$1,512.50 |
| Large Equipment Costs | 1 | LS | | | | | \$124,753.13 |
| Construction Contingency (15%) | 1 | LS | | | | | \$611,024.04 |
| Substation Construction Sub Totals | | | | | | 3,992 | \$4,684,517.67 |
| Engineering | 1 | LS | | | | | \$351,338.83 |
| Eagle Mountain City Costs | 1 | LS | | | | | \$70,267.77 |
| Total Substation Cost | | | | | | | \$5,106,124.26 |

* Loaded labor rate of \$75.00/Hour which includes labor, 20% overtime, labor overheads, FICA, social security, supervision, small tools and expendables, small trucks and profit.

ELECTRIC INFRASTRUCTURE COSTS - BUILD OUT POLE CANYON DEVELOPMENT

30 MVA 138 - 12.47Y/7.2 kV Transformer Addition

Drawing No. E103

| Item Description | Item Qty | Item Units | Unit Material Cost | Unit Labor Hours | Unit Labor Cost* | Total Item Labor Hours | Total Item Cost |
|--------------------------------------------|----------|------------|--------------------|------------------|------------------|------------------------|-----------------------|
| Mobilization/Demobilization & Bonding | 1 | lot | | 200 | \$30,000.00 | 400 | \$30,000.00 |
| Substation Site: | | | | | | | |
| 1. Chain Link Fencing | 0 | feet | | | | | \$0.00 |
| 2. Grading, Site Roads & Rock Surfacing | 1 | lot | | | | | \$15,000.00 |
| 3. Grounding (fence, structures & grid) | 1 | lot | \$35,828.00 | 200 | \$15,000.00 | 200 | \$15,000.00 |
| Concrete Pads/Foundations: | | | | | | | |
| 1. Power Transformer (56 yds) | 1 | each | \$10,360.00 | 241 | \$18,075.00 | 241 | \$28,435.00 |
| 2. Metal-clad Gear (20 yds) | 1 | each | \$8,500.00 | 117 | \$8,775.00 | 117 | \$17,275.00 |
| 3. H-frame Structure (6'x22' = 23 yds) | 0 | each | \$4,255.00 | 100 | \$7,500.00 | 0 | \$0.00 |
| 4. 138 kV Switch Str (3'x11' = 3 yds) | 1 | each | \$555.00 | 13 | \$975.00 | 13 | \$1,530.00 |
| 5. 138 kV 1 Ph Bus Supt (2'x11' = 1.5 yds) | 3 | each | \$277.50 | 7 | \$525.00 | 21 | \$2,407.50 |
| 6. 15 kV 3 Ph Bus Supt (2x2'x11' = 3 yds) | 2 | each | \$555.00 | 14 | \$1,050.00 | 28 | \$3,210.00 |
| 7. 138 kV Breaker (3'x11' = 3 yds) | 1 | each | \$555.00 | 13 | \$975.00 | 13 | \$1,530.00 |
| 8. Static Mast (4'x15' = 7 yds) | 2 | each | \$1,295.00 | 31 | \$2,325.00 | 62 | \$7,240.00 |
| High Voltage Equipment: | | | | | | | |
| 1. LTC Power Transformer, 18/24/30 MVA | 1 | each | \$1,125,000.00 | 250 | \$18,750.00 | 250 | \$1,143,750.00 |
| 2. 15 kV Metal-clad Switchgear | 1 | lineup | \$465,000.00 | 150 | \$11,250.00 | 150 | \$476,250.00 |
| 3. 138 kV Breaker | 1 | each | \$75,000.00 | 40 | \$3,000.00 | 40 | \$78,000.00 |
| 4. 15 kV, 2.5 MVAR Pad Mounted Capacitor | 0 | each | \$67,000.00 | 45 | \$3,375.00 | 0 | \$0.00 |
| 5. 138 kV GOAB Switch | 1 | each | \$9,500.00 | 40 | \$3,000.00 | 40 | \$12,500.00 |
| 6. 138 kV Arrester | 0 | each | \$500.00 | 4 | \$300.00 | 0 | \$0.00 |
| Steel Structures: | | | | | | | |
| 1. H-frame Entrance | 0 | each | \$35,000.00 | 80 | \$6,000.00 | 0 | \$0.00 |
| 2. 138 kV Switch | 1 | each | \$2,100.00 | 30 | \$2,250.00 | 30 | \$4,350.00 |
| 3. 138 kV 1 Ph Bus Support | 3 | each | \$1,100.00 | 10 | \$750.00 | 30 | \$5,550.00 |
| 4. 15 kV 3 Ph Bus Support | 2 | each | \$4,500.00 | 30 | \$2,250.00 | 60 | \$13,500.00 |
| 5. Static Mast | 2 | each | \$15,000.00 | 10 | \$750.00 | 20 | \$31,500.00 |
| 6. Switching Platforms | 1 | each | \$450.00 | 2 | \$150.00 | 2 | \$600.00 |
| Bus Work (Strain & Rigid): | | | | | | | |
| 1. 138 kV (insulators, bus & fittings) | 1 | lot | \$15,000.00 | 70 | \$5,250.00 | 70 | \$20,250.00 |
| 2. 12.5 kV (insulators, bus & fittings) | 1 | lot | \$10,000.00 | 25 | \$1,875.00 | 25 | \$11,875.00 |
| Cable, Conduit & Low Voltage Terminations | | | | | | | |
| 1. 15 kV Cable (to switchgear - 6 x 100') | 600 | feet | \$30.00 | 0.036 | \$2.70 | 21.6 | \$19,620.00 |
| 2. 6" Conduit (to switchgear - 8 x 100') | 600 | feet | \$2.50 | 0.025 | \$1.88 | 15 | \$2,625.00 |
| 3. Relay & Control | 1 | lot | \$16,000.00 | 120 | \$9,000.00 | 120 | \$25,000.00 |
| 4. Low Voltage AC and DC | 1 | lot | \$12,000.00 | 180 | \$13,500.00 | 180 | \$25,500.00 |
| 5. Trench & Backfill | 1 | lot | \$5,000.00 | 100 | \$7,500.00 | 100 | \$12,500.00 |
| Miscellaneous: | | | | | | | |
| 1. Terminations, 15 kV URD Cable | 9 | each | \$120.00 | 4 | \$300.00 | 36 | \$3,780.00 |
| 2. Yard Lights, Switches & Outlets | 1 | lot | \$4,000.00 | 45 | \$3,375.00 | 45 | \$7,375.00 |
| 3. Transmission Conductor & Dead Ends | 500 | feet | \$2.00 | 0.040 | \$3.00 | 20 | \$2,500.00 |
| 4. Transmission Shield Wire & Dead Ends | 550 | feet | \$0.50 | 0.030 | \$2.25 | 16.5 | \$1,512.50 |
| Large Equipment Costs | 1 | LS | | | | | \$73,940.63 |
| Construction Contingency (15%) | 1 | LS | | | | | \$314,115.84 |
| Substation Construction Sub Totals | | | | | | 2,366 | \$2,408,221.47 |
| Engineering | 1 | LS | | | | | \$108,369.97 |
| Eagle Mountain City Costs | 1 | LS | | | | | \$24,082.21 |
| Total Substation Cost | | | | | | | \$2,540,673.65 |

* Loaded labor rate of \$75.00/Hour which includes labor, 20% overtime, labor overheads, FICA, social security, supervision, small tools and expendables, small trucks and profit.

ELECTRIC INFRASTRUCTURE COSTS - PHASE 1

POLE CANYON DEVELOPMENT

12.47 kV Underground Main Feeders

Drawing No. E104

| Item Designation | Item Description | Item Quantity | Item Units | Unit Material Cost | Unit Labor Hours | Unit Labor Cost* | Total Item Labor Hours | Total Item Cost |
|--------------------------------------------------------|-----------------------------------------------------------------------------------------------------|---------------|------------|--------------------|------------------|------------------|------------------------|-----------------------|
| Misc | Bonding, Mobilization and Demobilization, Phasing, Testing and Energization | 1 | LS | | | | | \$65,487.47 |
| Cond | Direct Bureid 6" Schedule 40 PVC Conduit: | 23,505 | Feet | \$2.72 | 0.011 | \$0.83 | 258.56 | \$83,325.23 |
| Casing | Casing - 6" PVC Conduit at Road Crossings | 585 | Feet | \$6.50 | 0.018 | \$1.35 | 10.53 | \$4,592.25 |
| Cable | 750 kcmil Al 15 kV URD Cable With 220 Mills EPR Insulation, LLDPE Jacket and 1/3 Concentric Neutral | 47,655 | Feet | \$6.18 | 0.014 | \$1.05 | 667.17 | \$344,545.65 |
| Swgr | 15 kV Dead Front Pad Mounted Switchgear: | | | | | | | |
| | 1. PME9 Switchgear | 2 | Each | \$14,400.00 | 5 | \$375.00 | 10.00 | \$29,550.00 |
| | 2. PME11 Switchgear** | 5 | Each | \$15,260.00 | 5 | \$375.00 | 25.00 | \$78,175.00 |
| Cap | 15 kV, 2.5 MVAR Pad Mounted Capacitor | 2 | each | \$67,000.00 | 45 | \$3,375.00 | 90.00 | \$140,750.00 |
| Mtl-Clad | 15 kV Breaker for Metal Clad Switchgear | 3 | each | \$62,000.00 | 25 | \$3,375.00 | 90.00 | \$140,750.00 |
| Sect | 15 kV 600 Amp Sectionalizer | 13 | Each | \$600.00 | 3 | \$225.00 | 39.00 | \$10,725.00 |
| Box Pad | 15 kV Switchgear and Sectionalizer Box Pads: | | | | | | | |
| | 1. PME9 Switchgear | 2 | Each | \$1,400.00 | 8 | \$600.00 | 16.00 | \$4,000.00 |
| | 2. PME11 Switchgear | 5 | Each | \$1,400.00 | 8 | \$600.00 | 40.00 | \$10,000.00 |
| | 3. 15 kV 600 Amp Sect | 10 | Each | \$288.00 | 6 | \$450.00 | 60.00 | \$7,380.00 |
| | 4. 15 kV 600 Amp Sect (Future Switchgear) | 3 | Each | \$1,845.00 | 8 | \$600.00 | 24.00 | \$7,335.00 |
| Riser | 15 kV Overhead to Underground Riser | 6 | Each | \$1,845.00 | 25 | \$1,875.00 | 150.00 | \$22,320.00 |
| Jct | 15 kV, 600 Amp Non-Loadbreak Jct - 2 Way | 39 | Each | \$189.00 | 1 | \$75.00 | 39.00 | \$10,296.00 |
| Elbow | 15 kV, 600 Amp Non-Loadbreak Elbows with Test Points: | | | | | | | |
| | 1. Elbow with Stud (BOL-T) | 84 | Each | \$140.00 | 3 | \$225.00 | 252.00 | \$30,660.00 |
| | 2. Elbow with Insulating Cap (TOP-II) | 57 | Each | \$292.00 | 3 | \$225.00 | 171.00 | \$29,469.00 |
| | 3. Elbow Cold Shrink Seal | 141 | Each | \$10.65 | 0.25 | \$18.75 | 35.25 | \$4,145.40 |
| | 4. 15 kV, 200 Amp Insulating Cap | 9 | Each | \$35.00 | 0.25 | \$18.75 | 2.25 | \$483.75 |
| | 5. Connecting Plug - T Splices | 12 | Each | \$32.00 | 0.5 | \$37.50 | 6.00 | \$834.00 |
| Term | 15 kV Cold Shrink Cable Terminator | 9 | Each | \$110.00 | 3 | \$225.00 | 27.00 | \$3,015.00 |
| Manhole | Precast Concrete Manhole AASHTO H-20 Loading: | | | | | | | |
| | 1. 8' x 10' x 7' for Three 750 AL Circuits | 3 | Each | \$15,000.00 | 16 | \$1,200.00 | 48.00 | \$48,600.00 |
| | 2. 6' x 6' x 6' - 6" for Two 750 AL Circuits | 9 | Each | \$12,000.00 | 12 | \$900.00 | 108.00 | \$116,100.00 |
| Trench | Trench and Backfill for PVC Conduits for Electric Cables: | | | | | | | |
| | 1. Four Electric Conduits | 645 | Feet | | 0.135 | \$10.13 | 87.08 | \$6,530.63 |
| | 2. Two Electric Conduits | 5,860 | Feet | | 0.106 | \$7.95 | 621.16 | \$46,587.00 |
| | 3. One Electric Conduit | 9,205 | Feet | | 0.093 | \$6.98 | 856.07 | \$64,204.88 |
| Grnd | Equipment and Manhole Grounding: | | | | | | | |
| | 1. 15 kV Pad Mounted Switchgear | 7 | Each | \$150.00 | 3 | \$225.00 | 21.00 | \$2,625.00 |
| | 2. 15 kV 600 Amp Sectionalizer | 13 | Each | \$100.00 | 2 | \$150.00 | 26.00 | \$3,250.00 |
| | 3. Manhole | 12 | Each | \$250.00 | 6 | \$450.00 | 72.00 | \$8,400.00 |
| Label | Labeling of Cables In Equipment and Manholes: | | | | | | | |
| | 1. 15 kV Pad Mounted Switchgear | 5 | Each | \$125 | 2 | \$150.00 | 10.00 | \$1,375.00 |
| | 2. 15 kV 600 Amp Sectionalizer | 13 | Each | \$125.00 | 2 | \$150.00 | 26.00 | \$3,575.00 |
| | 3. Manhole | 12 | Each | \$250.00 | 3 | \$225.00 | 36.00 | \$5,700.00 |
| Fault | Three Phase Faulted Circuit Indicator for 15 kV Pad Mounted Switchgear | 5 | Each | \$225.00 | 0.20 | \$15.00 | 1.00 | \$1,200.00 |
| Equip | Large Equipment Costs | 1 | LS | | | | | \$39,250.55 |
| Cont | Construction Contingency (15%) | 1 | LS | | | | | \$206,285.52 |
| Electric Infrastructure Construction Sub Totals | | | | | | | 3,925 | \$1,581,522.31 |
| Engr | Engineering | 1 | LS | | | | | \$118,614.17 |
| City | Eagle Mountain City Costs | 1 | LS | | | | | \$23,722.83 |
| RMP | Buy Out Of RMP Electric Distribution Facilities | 1 | LS | | | | | \$250,000.00 |
| Total Electric Infrastructure Costs - Phase 1 | | | | | | | | \$1,973,859.32 |

* Loaded labor rate of \$75.00/Hour which includes labor, 20% overtime, labor overheads, FICA, social security, supervision, small tools and expendables, small trucks and profit.

** Two PME11 15 kV Pad Mounted Switchgear installed in development substation for capacitor banks.

NATURAL GAS INFRASTRUCTURE COSTS

POLE CANYON DEVELOPMENT

Low and High Pressure Gas System

Drawing No. G101

| Item Designation | Item Description | Item Quantity | Item Units | Unit Material Cost | Unit Labor Hours | Unit Labor Cost* | Total Item Labor Hours | Total Item Cost |
|----------------------------------------------------------------|--------------------------------------------------------------------------------------|---------------|------------|--------------------|------------------|------------------|------------------------|-----------------------|
| Misc | Bonding, Mobilization and Demobilization, Pressure Testing and System Pressurization | 1 | LS | | | | | \$64,050.47 |
| Pipe | Direct Bureid Polyethylene Gas Pipe: | | | | | | | |
| | 1. 4" Pipe - 40' Lengths | 75,010 | Feet | \$3.43 | 0.008 | \$0.60 | 600.08 | \$302,290.30 |
| | 2. 6" Pipe - 20' Lengths | 21,245 | Feet | \$6.18 | 0.014 | \$1.05 | 297.43 | \$153,601.35 |
| Tracer | #14 AWG Cu Tracer Wire - Yellow Insulation | 96,255 | Feet | \$0.30 | 0.005 | \$0.38 | 481.28 | \$64,972.13 |
| Splices | Fusion Splice - Polyethylene Gas Pipe: | | | | | | | |
| | 1. 4" Pipe - 40' Lengths | 1,876 | Each | \$2.00 | 1 | \$75.00 | 1,876.00 | \$144,452.00 |
| | 2. 6" Pipe - 20' Lengths | 1,062 | Each | \$5.00 | 1.25 | \$93.75 | 1,327.50 | \$104,872.50 |
| Tees | Fusion Tee - Polyethylene Gas Pipe: | | | | | | | |
| | 1. 4" Tee | 22 | Each | \$30.00 | 0.5 | \$37.50 | 11.00 | \$1,485.00 |
| | 2. 6" Tee | 10 | Each | \$65.00 | 1 | \$75.00 | 10.00 | \$1,400.00 |
| | 3. 6" to 4" Reducer | 8 | Each | \$35.00 | 0.25 | \$18.75 | 2.00 | \$430.00 |
| Trench | Trench and Backfill for Polyethylene Gas Pipe: | | | | | | | |
| | 1. One 4" or 6" Gas Pipe | 39,815 | Feet | | 0.094 | \$7.05 | 3,742.61 | \$280,695.75 |
| | 2. One 4" or 6" Gas Pipe with Electric Cables | 56,440 | Feet | | 0.02 | \$1.50 | 1,128.80 | \$84,660.00 |
| Equip | Large Equipment Costs | 1 | LS | | | | | \$142,150.43 |
| Cont | Construction Contingency (15%) | 1 | LS | | | | | \$201,758.99 |
| Low Pressure Gas Infrastructure Construction Sub Totals | | | | | | | 9,477 | \$1,345,059.92 |
| Engr | Engineering | 1 | LS | | | | | \$100,879.49 |
| City | Eagle Mountain City Costs | 1 | LS | | | | | \$20,175.90 |
| Total Low Pressure Gas Infrastructure Costs | | | | | | | | \$1,466,115.32 |

Drawing No. G102

| Item Designation | Item Description | Item Quantity | Item Units | Unit Material Cost | Unit Labor Hours | Unit Labor Cost* | Total Item Labor Hours | Total Item Cost |
|-----------------------------------------------------------------|--------------------------------------------------------------------------------------|---------------|------------|--------------------|------------------|------------------|------------------------|-----------------------|
| Misc | Bonding, Mobilization and Demobilization, Pressure Testing and System Pressurization | 1 | LS | | | | | \$51,669.78 |
| Pipe | 6" Steel HP Gas Pipe - 20' Lengths | 23,725 | Feet | \$20.00 | 0.025 | \$1.88 | 593.13 | \$518,984.38 |
| Splices | Splice 6" HP Steel Gas Pipe | 1,186 | Each | \$6.50 | 2.000 | \$150.00 | 2,372.00 | \$185,609.00 |
| Tie In | Connection to Existing 6" Steel HP Gas Pipe | 1 | LS | \$25,000.00 | 75 | \$5,625.00 | 75.00 | \$30,625.00 |
| Trench | Trench and Backfill for 6" HP Gas Pipe: | | | | | | | |
| | 1. One 6" HP Gas Pipe | 13,285 | Feet | | 0.134 | \$10.05 | 1,780.19 | \$133,514.25 |
| | 2. One 6" HP Gas Pipe with Other Gas Piping and/or Electric Cables | 10,440 | Feet | | 0.027 | \$2.03 | 281.88 | \$21,141.00 |
| Press Red | Pressure Reduction Site | 2 | Each | \$25,000.00 | 250 | \$18,750.00 | 500.00 | \$87,500.00 |
| Equip | Large Equipment Costs | 1 | LS | | | | | \$56,021.95 |
| Cont | Construction Contingency (15%) | 1 | LS | | | | | \$162,759.80 |
| High Pressure Gas Infrastructure Construction Sub Totals | | | | | | | 5,102 | \$941,543.40 |
| Engr | Engineering | 1 | LS | | | | | \$70,615.76 |
| City | Eagle Mountain City Costs | 1 | LS | | | | | \$14,123.15 |
| Total High Pressure Gas Infrastructure Costs | | | | | | | | \$1,026,282.31 |

* Loaded labor rate of \$75.00/Hour which includes labor, 20% overtime, labor overheads, FICA, social security, supervision, small tools and expendables, small trucks and profit.

NATURAL GAS INFRASTRUCTURE COSTS - PHASE 1 POLE CANYON DEVELOPMENT

Low Pressure Gas System

Drawing No. G103

| Item Designation | Item Description | Item Quantity | Item Units | Unit Material Cost | Unit Labor Hours | Unit Labor Cost* | Total Item Labor Hours | Total Item Cost |
|----------------------------------------------------------------|-----------------------------------------------------------------------------------------------------------------------------|-----------------|----------------------|-------------------------------|------------------|-------------------------------|------------------------|----------------------------------|
| Misc | Bonding, Mobilization and Demobilization, Pressure Testing and System Pressurization | 1 | LS | | | | | \$25,566.05 |
| Pipe | Direct Bureid Polyethylene Gas Pipe: 1. 4" Pipe - 40' Lengths 2. 6" Pipe - 20' Lengths | 12,255 7,400 | Feet Feet | \$3.43 \$6.18 | 0.008 0.014 | \$0.60 \$1.05 | 98.04 103.60 | \$49,387.65 \$53,502.00 |
| Tracer | #14 AWG Cu Tracer Wire - Yellow Insulation | 19,655 | Feet | \$0.30 | 0.005 | \$0.38 | 98.28 | \$13,267.13 |
| Splices | Fusion Splice - Polyethylene Gas Pipe: 1. 4" Pipe - 40' Lengths 2. 6" Pipe - 20' Lengths | 307 370 | Each Each | \$2.00 \$5.00 | 1 1.25 | \$75.00 \$93.75 | 307.00 462.50 | \$23,639.00 \$36,537.50 |
| Tees | Fusion Tee - Polyethylene Gas Pipe: 1. 4" Tee 2. 6" Tee 3. 6" to 4" Reducer | 10 4 4 | Each Each Each | \$30.00 \$65.00 \$35.00 | 0.5 1 0.25 | \$37.50 \$75.00 \$18.75 | 5.00 4.00 1.00 | \$675.00 \$560.00 \$215.00 |
| Trench | Trench and Backfill for Polyethylene Gas Pipe: 1. One 4" or 6" Gas Pipe 2. One 4" or 6" Gas Pipe with Electric Cables | 3,950 15,705 | Feet Feet | | 0.094 0.02 | \$7.05 \$1.50 | 371.30 314.10 | \$27,847.50 \$23,557.50 |
| Equip | Large Equipment Costs | 1 | LS | | | | | \$26,472.23 |
| Cont | Construction Contingency (15%) | 1 | LS | | | | | \$42,183.98 |
| Low Pressure Gas Infrastructure Construction Sub Totals | | | | | | | 1,765 | \$281,226.55 |
| Engr | Engineering | 1 | LS | | | | | \$21,091.99 |
| City | Eagle Mountain City Costs | 1 | LS | | | | | \$4,218.40 |
| Total Low Pressure Gas Infrastructure Costs | | | | | | | | \$306,536.94 |

* Loaded labor rate of \$75.00/Hour which includes labor, 20% overtime, labor overheads, FICA, social security, supervision, small tools and expendables, small trucks and profit.

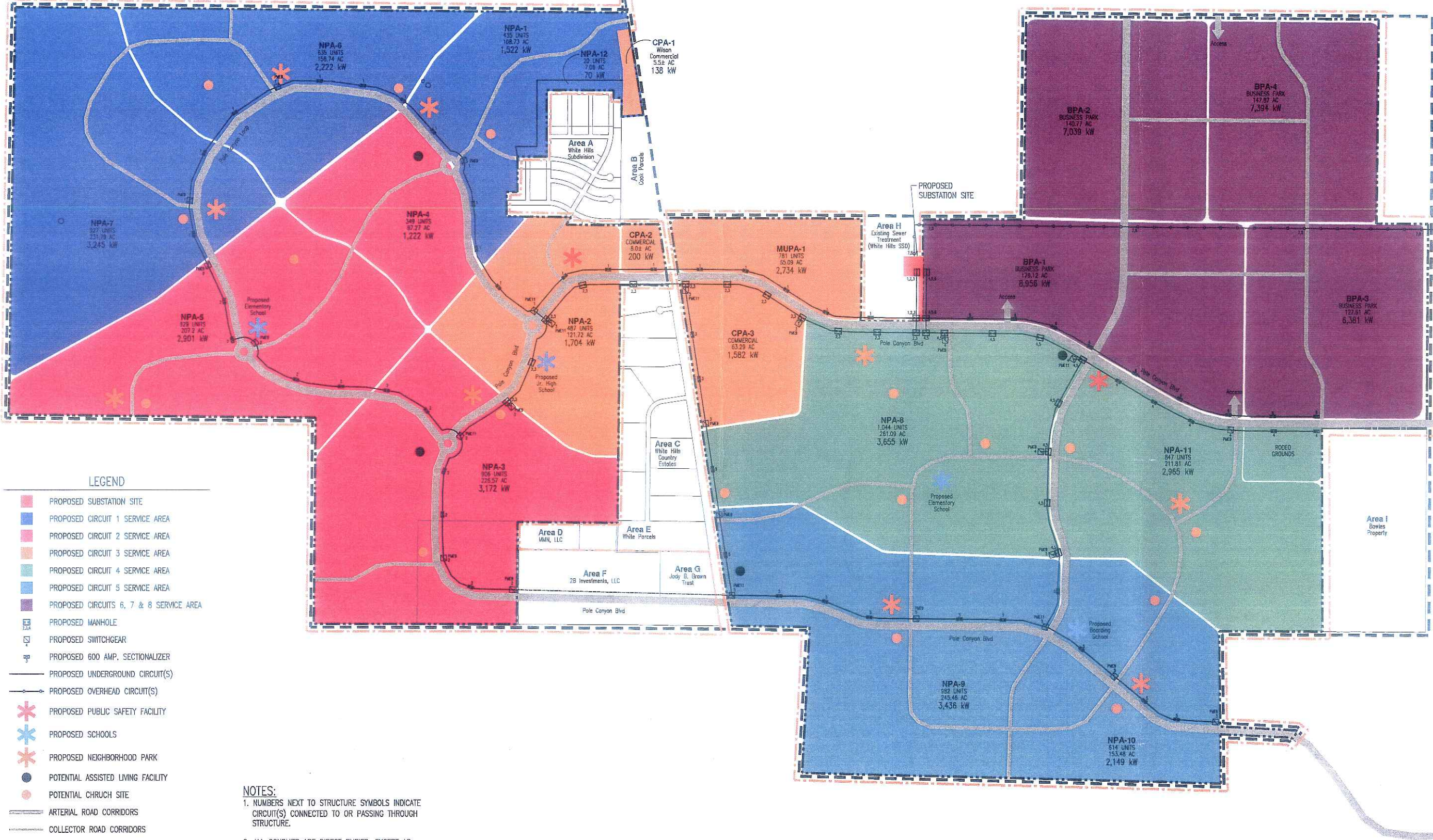

LEGEND

- PROPOSED SUBSTATION SITE
- PROPOSED CIRCUIT 1 SERVICE AREA
- PROPOSED CIRCUIT 2 SERVICE AREA
- PROPOSED CIRCUIT 3 SERVICE AREA
- PROPOSED CIRCUIT 4 SERVICE AREA
- PROPOSED CIRCUIT 5 SERVICE AREA
- PROPOSED CIRCUITS 6, 7 & 8 SERVICE AREA
- PROPOSED MANHOLE
- PROPOSED SWITCHGEAR
- PROPOSED 600 AMP. SECTIONALIZER
- PROPOSED UNDERGROUND CIRCUIT(S)
- PROPOSED OVERHEAD CIRCUIT(S)
- PROPOSED PUBLIC SAFETY FACILITY
- PROPOSED SCHOOLS
- PROPOSED NEIGHBORHOOD PARK
- POTENTIAL ASSISTED LIVING FACILITY
- POTENTIAL CHURCH SITE
- ARTERIAL ROAD CORRIDORS
- COLLECTOR ROAD CORRIDORS
- ANNEXATION BOUNDARY
- DEVELOPMENT AGREEMENT BOUNDARY
- LOCAL AREA DISTRICT BOUNDARY

NOTES:
 1. NUMBERS NEXT TO STRUCTURE SYMBOLS INDICATE CIRCUIT(S) CONNECTED TO OR PASSING THROUGH STRUCTURE.
 2. ALL CONDUITS ARE DIRECT BURIED, EXCEPT AS OTHERWISE NOTED.

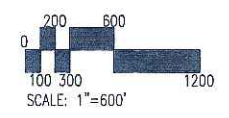

PRINTED 04/22/08 FOR DATE
 PRELIMINARY
 DESIGN DEVELOPMENT
 BIDDING
 CONSTRUCTION
 APPROVAL
 AS BUILT
 REVISION

Intermountain Consumer Professional Engineers, Inc.
 REGISTERED PROFESSIONAL ENGINEERS
 1748 E. 800TH STREET, SUITE 100
 MOUNTAIN VIEW, UTAH 84040
 PHONE: (435) 225-1111 FAX: 508-0208

| REVISIONS | | DATE | BY | APPD. |
|-----------|----------------|----------|-----|-------|
| A | INITIAL DESIGN | 04/22/08 | KAC | LAB |

| | | | | | |
|--------------|-----|--------------------------------------------------------------------------------|----------|--------------|-------|
| TITLE | | DEVELOPMENT ASSOCIATES, Inc. | | | |
| | | POLE CANYON EAGLE MOUNTAIN CITY, UTAH ELECTRIC DISTRIBUTION CONCEPT PLAN | | | |
| Drawn By: | KAC | Date: | 04/22/08 | ENGR.: | LAB |
| Chk'd. By: | LAB | Date: | 04/22/08 | APPD.: | AJT |
| Project No.: | | SCALE: | 1"=600' | DRAWING No.: | E101A |

CONFIDENTIAL

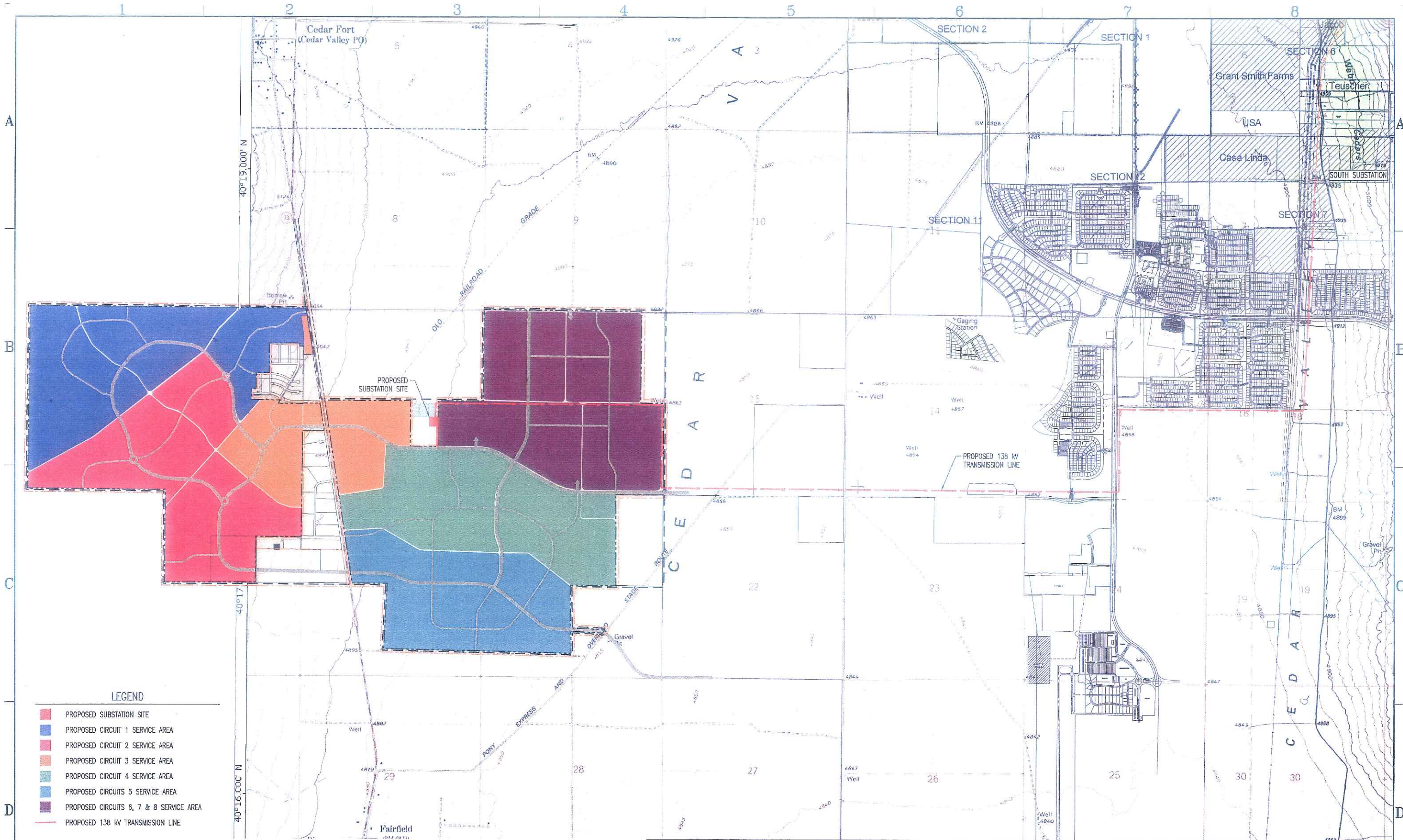

- LEGEND**
- PROPOSED SUBSTATION SITE
 - PROPOSED CIRCUIT 1 SERVICE AREA
 - PROPOSED CIRCUIT 2 SERVICE AREA
 - PROPOSED CIRCUIT 3 SERVICE AREA
 - PROPOSED CIRCUIT 4 SERVICE AREA
 - PROPOSED CIRCUITS 5 SERVICE AREA
 - PROPOSED CIRCUITS 6, 7 & 8 SERVICE AREA
 - PROPOSED 138 KV TRANSMISSION LINE

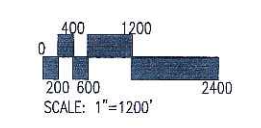

PRINTED 04/22/08 FOR DATE

- PRELIMINARY
- DESIGN DEVELOPMENT
- BIDDING
- CONSTRUCTION
- APPROVAL
- AS BUILT
- REVISION

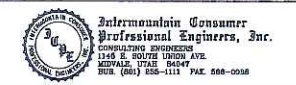

THE DRAWINGS, DESIGNS, IDEAS, ARRANGEMENTS AND PLANS INDICATED OR REPRESENTED ARE THE SOLE PROPERTY OF DEBRA MOUNTAIN CONSUMER PROFESSIONAL ENGINEERS, INC. (D.M.C.E.) AND ARE SUBJECT TO THE CONTROL OF ONE OR ITS ASSOCIATES. THEY HAVE BEEN CREATED, DEVELOPED AND REVISED EXCLUSIVELY FOR USE ON, AND IN CONNECTION WITH, THE SPECIFIED PROJECT. ANY USE OF THE DRAWINGS, DESIGNS, ARRANGEMENTS OR INFORMATION CONTAINED HEREIN, INCLUDING COPYING, WHICH IS NOT EXPRESSLY AUTHORIZED BY D.M.C.E., IS STRICTLY PROHIBITED AS AN INFRINGEMENT OF ITS COPYRIGHT AND MAY RESULT IN LIABILITY. ©2008 D.M.C.E.

| REVISIONS | | | | TITLE | |
|-----------|----------------|-----|----------|-------|-----|
| No. | DESCRIPTION | BY | DATE | ENGR. | LAB |
| A | INITIAL DESIGN | KAC | 04/22/08 | LAB | |

| | | | | | | | | | | |
|--------------|-----|--------|----------|-------|-----|-------|----------|-------------|-------|----------|
| Drawn By: | KAC | Date: | 04/22/08 | ENGR. | LAB | Date: | 04/16/08 | DRAWING No. | E102A | REVISION |
| Ch'k'd. By: | LAB | Date: | 04/22/08 | APPD. | AJT | Date: | | | | |
| Project No.: | | SCALE: | 1"=1200' | | | | | | | |

CONFIDENTIAL

DEVELOPMENT ASSOCIATES, Inc.
POLE CANYON
EAGLE MOUNTAIN CITY, UTAH
ELECTRIC TRANSMISSION CONCEPT PLAN

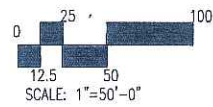
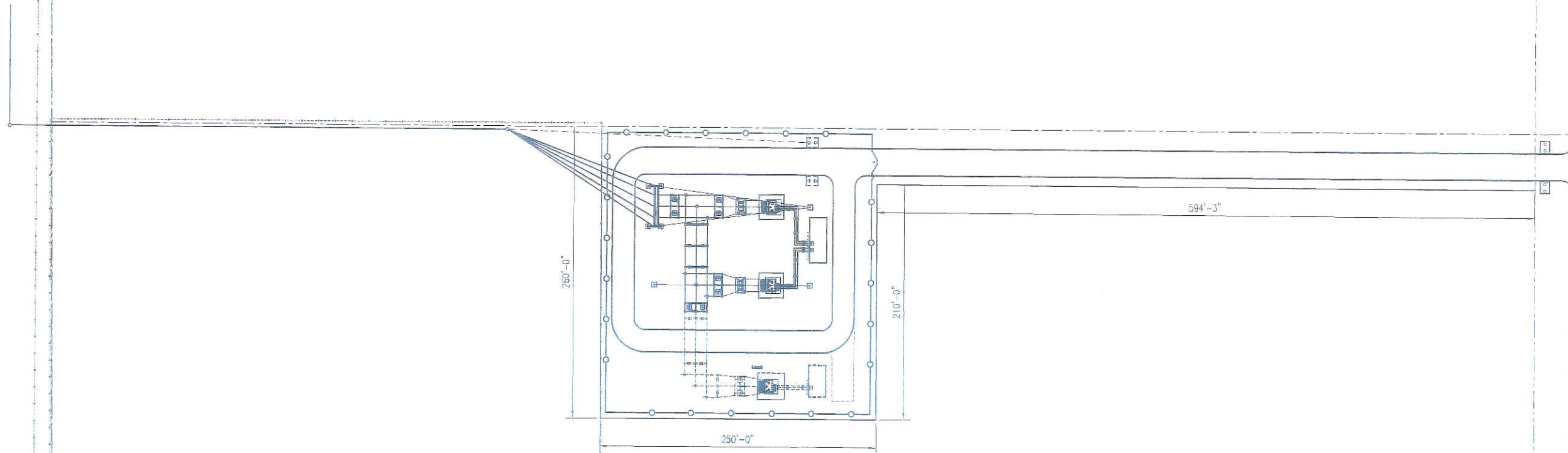

PRINTED 04/22/08 FOR
DATE

PRELIMINARY
 DESIGN DEVELOPMENT
 BIDDING
 CONSTRUCTION
 APPROVAL
 AS BUILT
 REVISION



THE DRAWINGS, RECORDS, DEGS, ARRANGEMENTS AND PLANS INDICATED OR REPRESENTED ARE THE SOLE PROPERTY OF EAGLE MOUNTAIN CONSULTING PROFESSIONAL ENGINEERS, INC. (E.M.C.E.) AND ARE SUBJECT TO THE COPYRIGHT OF E.M.C.E. OR ITS ASSOCIATES. THEY HAVE BEEN CREATED, DEVELOPED AND REVISED EXCLUSIVELY FOR USE ON, AND IN CONNECTION WITH, THE SPECIFIC PROJECT AND USE OF THE DRAWINGS, RECORDS, MATERIAL OR INFORMATION CONTAINED HEREIN, INCLUDING COPYING, WHICH IS NOT EXPRESSLY AUTHORIZED BY E.M.C.E., IS STRICTLY PROHIBITED AS AN INFRINGEMENT OF ITS COPYRIGHT AND MAY RESULT IN DAMAGES. © E.M.C.E. 1999

| No. | DESCRIPTION | BY | DATE | APPD. |
|---------------------|----------------|-----|----------|-------|
| A | INITIAL DESIGN | KAC | 04/22/08 | LAB |
| REVISIONS | | | | |
| CONFIDENTIAL | | | | |

| | | | | | |
|--------------|-----|----------------------------------|----------|-------|---------------|
| TITLE | | DEVELOPMENT ASSOCIATES, Inc. | | | |
| | | POLE CANYON | | | |
| | | EAGLE MOUNTAIN CITY, UTAH | | | |
| | | ELECTRIC SUBSTATION CONCEPT PLAN | | | |
| Drawn By: | KAC | Date: | 04/22/08 | ENGR. | LAB |
| Chk'd. By: | LAB | Date: | 04/22/08 | APPD. | AJT |
| Project No.: | - | SCALE: | 1"=50' | | |
| DRAWING No. | | | | | E103 A |
| REVISION | | | | | |

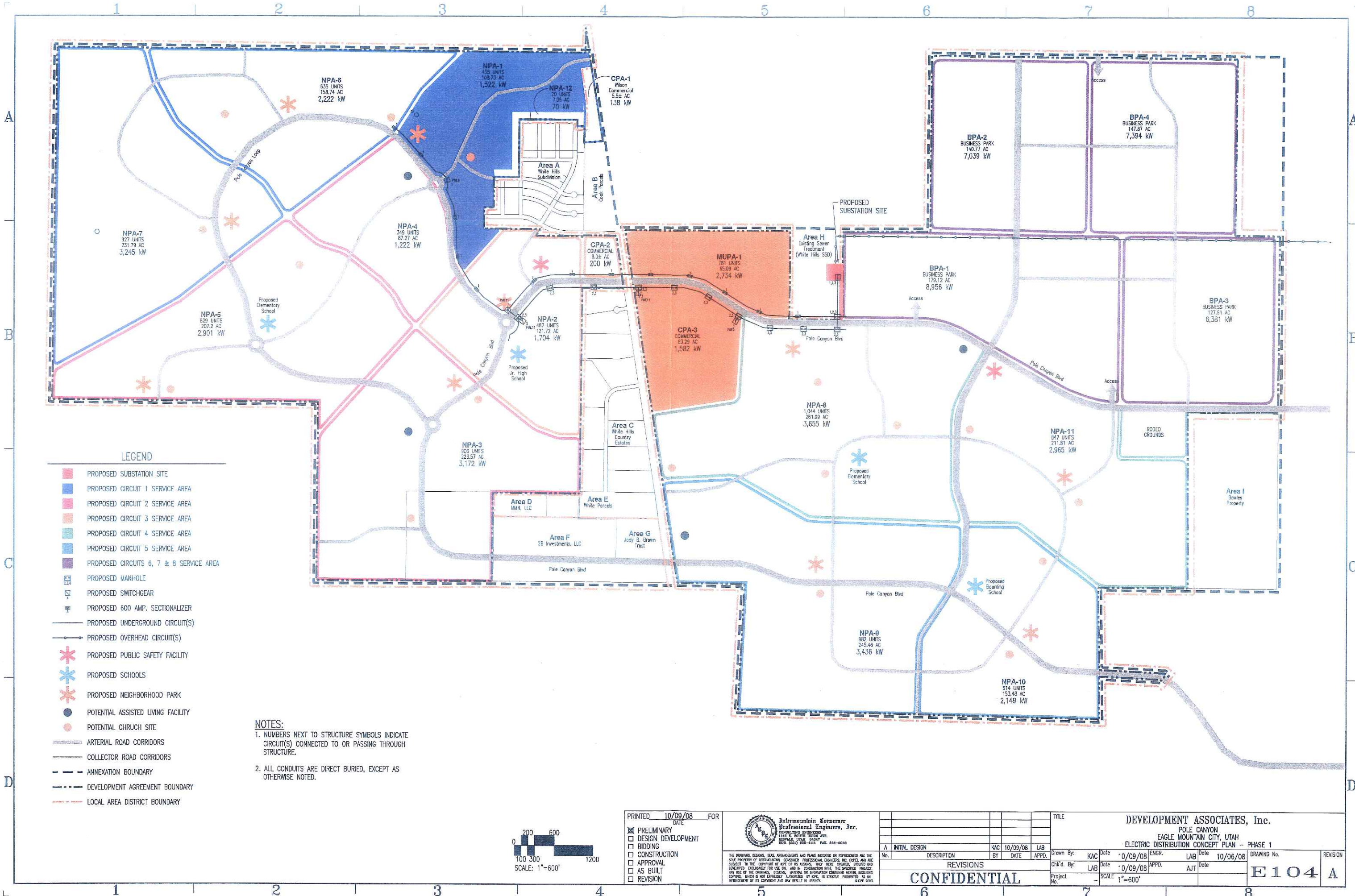

LEGEND

- PROPOSED SUBSTATION SITE
- PROPOSED CIRCUIT 1 SERVICE AREA
- PROPOSED CIRCUIT 2 SERVICE AREA
- PROPOSED CIRCUIT 3 SERVICE AREA
- PROPOSED CIRCUIT 4 SERVICE AREA
- PROPOSED CIRCUIT 5 SERVICE AREA
- PROPOSED CIRCUITS 6, 7 & 8 SERVICE AREA
- PROPOSED MANHOLE
- PROPOSED SWITCHGEAR
- PROPOSED 600 AMP. SECTIONALIZER
- PROPOSED UNDERGROUND CIRCUIT(S)
- PROPOSED OVERHEAD CIRCUIT(S)
- PROPOSED PUBLIC SAFETY FACILITY
- PROPOSED SCHOOLS
- PROPOSED NEIGHBORHOOD PARK
- POTENTIAL ASSISTED LIVING FACILITY
- POTENTIAL CHURCH SITE
- ARTERIAL ROAD CORRIDORS
- COLLECTOR ROAD CORRIDORS
- ANNEXATION BOUNDARY
- DEVELOPMENT AGREEMENT BOUNDARY
- LOCAL AREA DISTRICT BOUNDARY

NOTES:
 1. NUMBERS NEXT TO STRUCTURE SYMBOLS INDICATE CIRCUIT(S) CONNECTED TO OR PASSING THROUGH STRUCTURE.
 2. ALL CONDUITS ARE DIRECT BURIED, EXCEPT AS OTHERWISE NOTED.

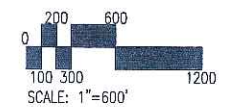

PRINTED 10/09/08 FOR DATE
 PRELIMINARY
 DESIGN DEVELOPMENT
 BIDDING
 CONSTRUCTION
 APPROVAL
 AS BUILT
 REVISION

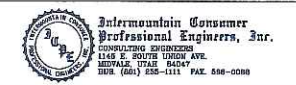

THE DRAWINGS, DESIGNS, REVISIONS AND PLANS INDICATED OR REPRESENTED ARE THE SOLE PROPERTY OF EAGLE MOUNTAIN CONSUMER PROFESSIONAL ENGINEERS, INC. (EMCE) AND ARE SUBJECT TO THE COPYRIGHT OF ONE OR ITS ASSOCIATES. THEY WERE CREATED, DESIGNED AND DEVELOPED EXCLUSIVELY FOR USE ON, AND IN CONNECTION WITH, THE SPECIFIED PROJECT. ANY USE OF THE DRAWINGS, DESIGNS, REVISIONS OR INFORMATION CONTAINED HEREIN, INCLUDING COPYING, WHICH IS NOT EXPRESSLY AUTHORIZED BY EMCE, IS STRICTLY PROHIBITED AS AN INFRINGEMENT OF ITS COPYRIGHT AND MAY RESULT IN LIABILITY. ©EMCE 2003

| REVISIONS | | DATE | BY | DATE | APPD. | LAB |
|------------------|--|-------------|-----|----------|-------|-----|
| A INITIAL DESIGN | | 10/09/08 | KAC | 10/09/08 | LAB | LAB |
| No. | | DESCRIPTION | BY | DATE | APPD. | LAB |

| | | | | | |
|---------------------------------------------------------------------------------------------------------------------------------|-----|--------|----------|--------------|----------|
| CONFIDENTIAL | | | | | |
| TITLE: DEVELOPMENT ASSOCIATES, Inc. POLE CANYON EAGLE MOUNTAIN CITY, UTAH ELECTRIC DISTRIBUTION CONCEPT PLAN - PHASE 1 | | | | | |
| Drawn By: | KAC | Date: | 10/09/08 | ENGR. | LAB |
| Chk'd. By: | LAB | Date: | 10/09/08 | APPD. | AJT |
| Project No.: | - | SCALE: | 1"=600' | DRAWING No.: | E104 A |
| | | | | | REVISION |

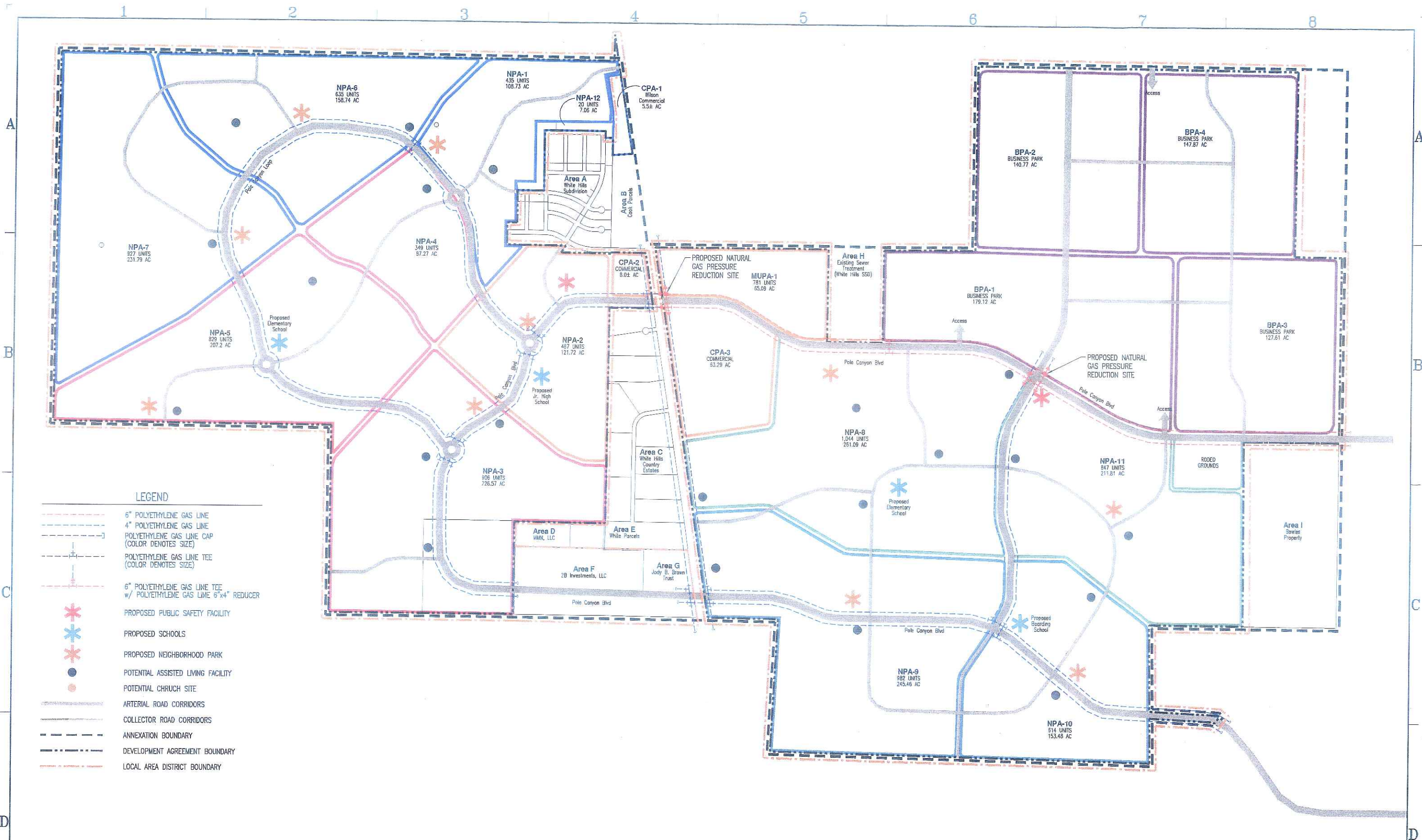

- LEGEND**
- 6" POLYETHYLENE GAS LINE
 - 4" POLYETHYLENE GAS LINE
 - POLYETHYLENE GAS LINE CAP (COLOR DENOTES SIZE)
 - POLYETHYLENE GAS LINE TEE (COLOR DENOTES SIZE)
 - 6" POLYETHYLENE GAS LINE TEE w/ POLYETHYLENE GAS LINE 6"x4" REDUCER
 - PROPOSED PUBLIC SAFETY FACILITY
 - PROPOSED SCHOOLS
 - PROPOSED NEIGHBORHOOD PARK
 - POTENTIAL ASSISTED LIVING FACILITY
 - POTENTIAL CHURCH SITE
 - ARTERIAL ROAD CORRIDORS
 - COLLECTOR ROAD CORRIDORS
 - ANNEXATION BOUNDARY
 - DEVELOPMENT AGREEMENT BOUNDARY
 - LOCAL AREA DISTRICT BOUNDARY

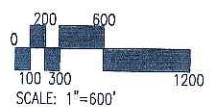

PRINTED 04/22/08 FOR
 DATE
 PRELIMINARY
 DESIGN DEVELOPMENT
 BIDDING
 CONSTRUCTION
 APPROVAL
 AS BUILT
 REVISION

Intermountain Consumer Professional Engineers, Inc.
 2140 E. SOUTH LINDEN AVE.
 SPOKANE, IDAHO 83409
 PH: (801) 858-1111 FAX: 508-0088

THE DRAWINGS, DESIGN, SPEC. ARRANGEMENTS AND PLANS INDICATED OR REPRESENTED ARE THE SOLE PROPERTY OF INTERMOUNTAIN CONSUMER PROFESSIONAL ENGINEERS, INC. (ICE) AND ARE SUBJECT TO THE COPYRIGHT OF ICE OR ITS ASSOCIATES. THEY WERE CREATED, ENGINEERED AND DEVELOPED EXCLUSIVELY FOR USE ON, AND IN CONNECTION WITH, THE SPECIFIED PROJECT. ANY USE OF THE DRAWINGS, DESIGN, MATERIAL OR INFORMATION CONTAINED HEREIN, INCLUDING COPYING, WHICH IS NOT EXPRESSLY AUTHORIZED BY ICE, IS STRICTLY PROHIBITED AS AN INFRINGEMENT OF ITS COPYRIGHT AND MAY RESULT IN LIABILITY. ©ICE 2003

| No. | DESCRIPTION | BY | DATE | APPD. |
|---------------------|----------------|-----|----------|-------|
| A | INITIAL DESIGN | KAC | 04/22/08 | LAB |
| REVISIONS | | | | |
| CONFIDENTIAL | | | | |

| | | | | | |
|--------------|-----|-----------------------------------------------------------------------------------|----------|--------------|--------------|
| TITLE | | DEVELOPMENT ASSOCIATES, Inc. | | | |
| | | POLE CANYON EAGLE MOUNTAIN CITY, UTAH NATURAL GAS DISTRIBUTION CONCEPT PLAN | | | |
| Drawn By: | KAC | Date: | 04/22/08 | ENGR.: | LAB |
| Chk'd. By: | LAB | Date: | 04/22/08 | APPD.: | AJT |
| Project No.: | | SCALE: | 1"=600' | DRAWING No.: | G101A |
| | | | | | REVISION |

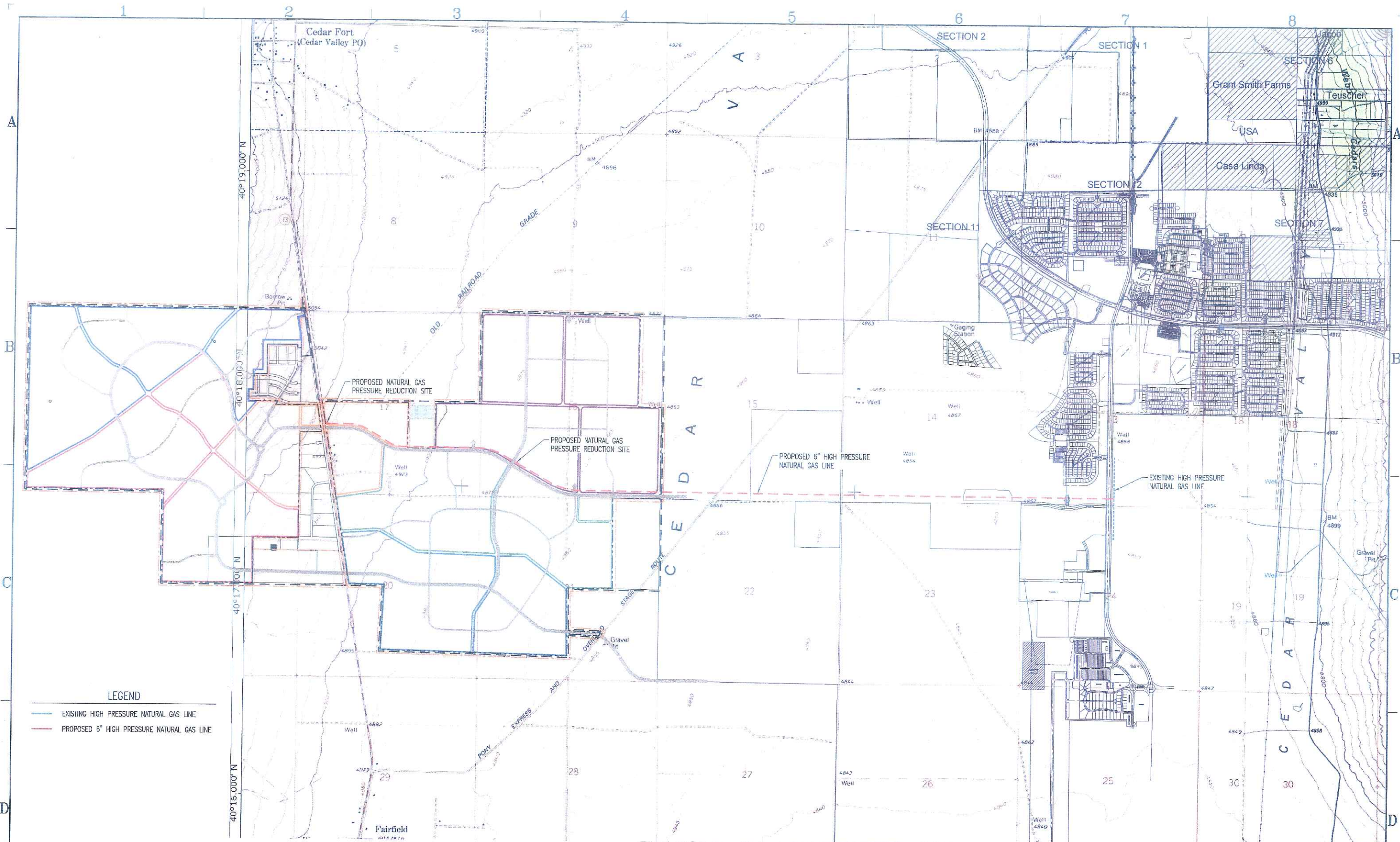

LEGEND

— EXISTING HIGH PRESSURE NATURAL GAS LINE

— PROPOSED 6" HIGH PRESSURE NATURAL GAS LINE

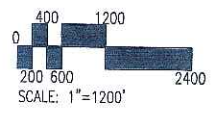

PRINTED 04/22/08 FOR
DATE

PRELIMINARY
 DESIGN DEVELOPMENT
 BIDDING
 CONSTRUCTION
 APPROVAL
 AS BUILT
 REVISION

Intermountain Consumer Professional Engineers, Inc.
 CONSULTING ENGINEERS
 1440 E. 8000 SOUTH AVENUE
 HOVINGDEAN, UTAH 84044
 PH. (801) 225-1111 FAX 508-0088

| REVISIONS | | BY | DATE | APPD. |
|-----------|----------------|-----|----------|-------|
| A | INITIAL DESIGN | KAC | 04/22/08 | LAB |

DEVELOPMENT ASSOCIATES, Inc.
 POLE CANYON
 EAGLE MOUNTAIN CITY, UTAH
 NATURAL GAS TRANSMISSION CONCEPT PLAN

Drawn By: KAC Date 04/22/08 ENGR. LAB Date 04/16/08
 Chk'd. By: LAB Date 04/22/08 APPD. AJT Date
 Project No. SCALE 1"=1200'

CONFIDENTIAL

DRAWING No. **G102 A** REVISION

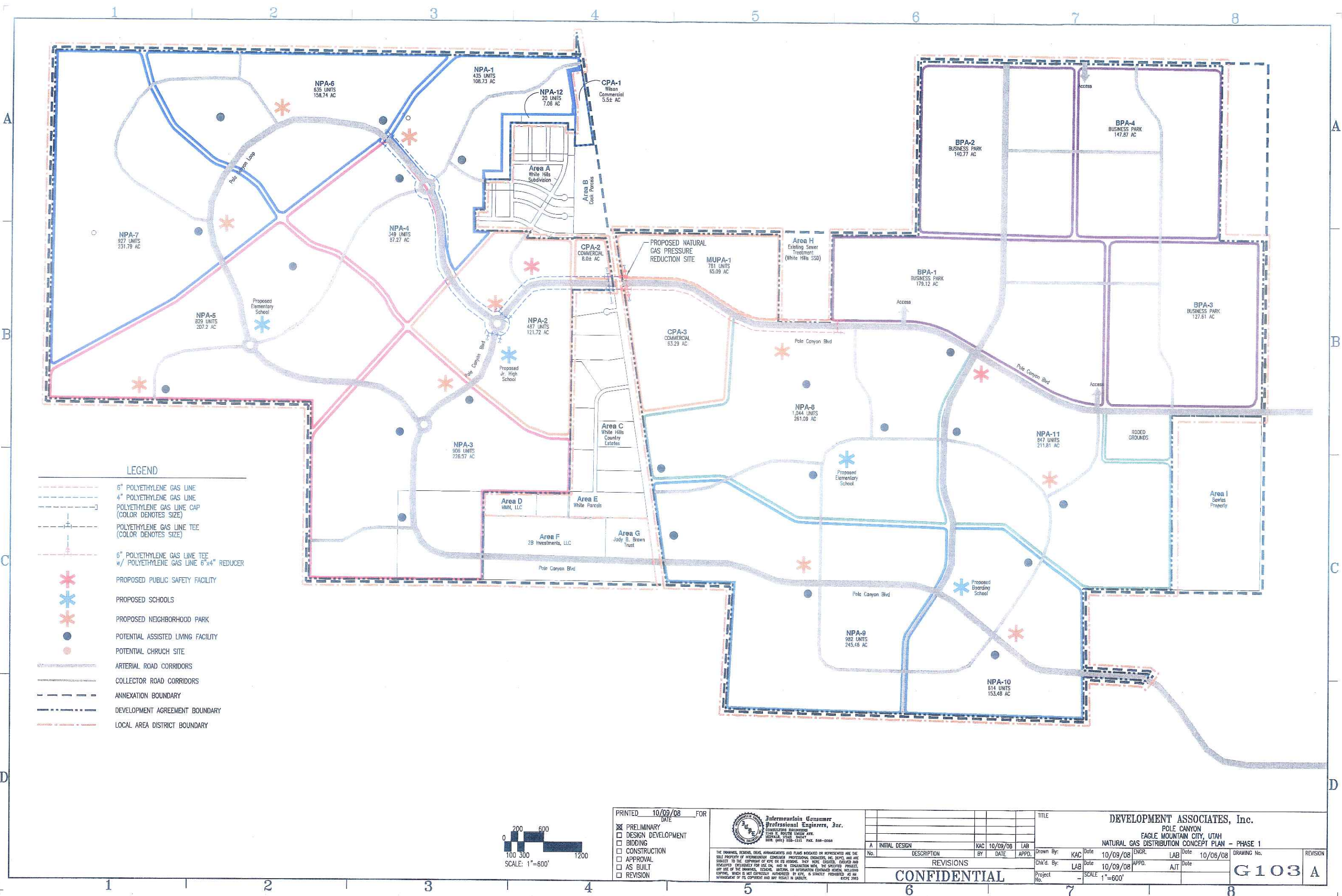

LEGEND

- 6" POLYETHYLENE GAS LINE
- 4" POLYETHYLENE GAS LINE
- POLYETHYLENE GAS LINE CAP (COLOR DENOTES SIZE)
- POLYETHYLENE GAS LINE TEE (COLOR DENOTES SIZE)
- 6" POLYETHYLENE GAS LINE TEE w/ POLYETHYLENE GAS LINE 6"x4" REDUCER
- PROPOSED PUBLIC SAFETY FACILITY
- PROPOSED SCHOOLS
- PROPOSED NEIGHBORHOOD PARK
- POTENTIAL ASSISTED LIVING FACILITY
- POTENTIAL CHURCH SITE
- ARTERIAL ROAD CORRIDORS
- COLLECTOR ROAD CORRIDORS
- ANNEXATION BOUNDARY
- DEVELOPMENT AGREEMENT BOUNDARY
- LOCAL AREA DISTRICT BOUNDARY

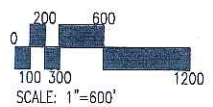

PRINTED 10/09/08 FOR DATE

PRELIMINARY
 DESIGN DEVELOPMENT
 BIDDING
 CONSTRUCTION
 APPROVAL
 AS BUILT
 REVISION

Intermountain Consumer Professional Engineers, Inc.
 CONSULTING ENGINEERS
 1145 E. SOUTH UTAH AVE.
 DENVER, COLORADO 80202
 303.733.1111 FAX: 303.733.0088

THE FIRM'S, RECORDS, SEAL, ARRANGEMENTS AND PLANS INDICATED OR REPRESENTED ARE THE SOLE PROPERTY OF INTERMOUNTAIN CONSUMER PROFESSIONAL ENGINEERS, INC. (ICPE), AND ARE LOANED TO THE EMPLOYMENT OF ONE OF ITS ASSOCIATES. THEY WERE CREATED, EXERCISED AND REPRODUCED EXCLUSIVELY FOR USE ONLY AND IN CONNECTION WITH THE SPECIFIC PROJECT. ANY USE OF THE DRAWINGS, DESIGNS, INTERNAL OR INFORMATION CONTAINED HEREIN, INCLUDING COPYING, WHICH IS NOT EXPRESSLY AUTHORIZED BY ICPE, IS STRICTLY PROHIBITED AS AN INFRINGEMENT OF ITS COPYRIGHT AND MAY RESULT IN LIABILITY. ©ICPE 2003

| REVISIONS | | | | TITLE | | | |
|-----------|----------------|-----|----------|----------|------|------|------|
| No. | DESCRIPTION | BY | DATE | APPROVED | DATE | DATE | DATE |
| A | INITIAL DESIGN | KAC | 10/09/08 | LAB | | | |

Drawn By: KAC Date: 10/09/08 ENGR. LAB Date: 10/06/08
 Chk'd. By: LAB Date: 10/09/08 APPD. AJT Date: 10/06/08

Project No. - SCALE 1"=600'

CONFIDENTIAL

DEVELOPMENT ASSOCIATES, Inc.
 POLE CANYON
 EAGLE MOUNTAIN CITY, UTAH
 NATURAL GAS DISTRIBUTION CONCEPT PLAN - PHASE 1

DRAWING No. **G103 A** REVISION

Exhibit 7 – Traffic Impact Study

POLE CANYON TRAFFIC IMPACT STUDY

**Prepared For:
Development Associate Inc.**

Prepared By:

DMJM HARRIS | AECOM

**935 E. South Union Avenue, Suite D-203
Midvale, UT 84047 (801) 569-2131 (801) 569-2149 Fax**

**November 7, 2008
DMJM Harris Project No. 60041661**

POLE CANYON TRAFFIC IMPACT STUDY

Prepared For:
Development Associate Inc.

Prepared By:

DMJM HARRIS | AECOM

935 E. South Union Avenue, Suite D-203
Midvale, UT 84047 (801) 569-2131 (801) 569-2149 Fax

November 7, 2008
DMJM Harris Project No. 60041661

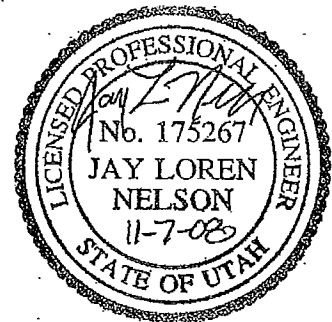

TABLE OF CONTENTS

| | | |
|-----|-----------------------------------------------|----|
| 1.0 | INTRODUCTION..... | 1 |
| 1.1 | <i>Purpose and Objective of Study</i> | 1 |
| 1.2 | <i>Project Description and Location</i> | 1 |
| 2.0 | EXISTING TRAFFIC CONDITIONS..... | 5 |
| 3.0 | PROJECT TRAFFIC FORECAST | 8 |
| 3.1 | <i>Trip Generation</i> | 8 |
| 3.2 | <i>Project Trip Distribution</i> | 11 |
| 4.0 | LEVEL OF SERVICE ANALYSIS | 18 |
| 4.1 | <i>Level of Service Concept</i> | 18 |
| 4.2 | <i>Results of LOS Analysis</i> | 19 |
| 5.0 | SUMMARY AND CONCLUSIONS..... | 21 |

LIST OF FIGURES

Figure 1 Project Vicinity and External Study Intersections..... 2

Figure 2 Internal Study Intersections 3

Figure 3 Project Concept Plan..... 4

Figure 4 Existing 2008 Peak Hour Traffic Volumes 6

Figure 5 Background 2023 Peak Hour Traffic Volumes..... 7

Figure 6 Residential Project Trip Distribution..... 12

Figure 7 Business Park Project Trip Distribution..... 13

Figure 8 Mixed-Use Project Trip Distribution..... 14

Figure 9 Project Traffic Volumes at External Study Intersections 15

Figure 10 Project Traffic Volumes at Internal Study Intersections 16

Figure 11 Background 2023 plus Project Traffic Volumes..... 17

LIST OF TABLES

Table 1 Business Park Trip Generation Forecast 8

Table 2 Residential/School Trip Generation Forecast 9

Table 3 Mixed Use Trip Generation Forecast 10

Table 4 Trip Generation Forecast Summary 11

Table 5 LOS Criteria for Stopped Movements at Unsignalized Intersections..... 18

Table 6 LOS Criteria for Roundabouts 18

Table 7 LOS Criteria for Signalized Intersections 19

Table 8 External Intersection Peak Hour LOS Summary 19

Table 9 Internal Intersection Peak Hour LOS Summary 20

LIST OF APPENDICES

- APPENDIX A TURNING MOVEMENTS COUNTS
- APPENDIX B TRAFFIX REPORT SHEETS

1.0 INTRODUCTION

Eagle Mountain City and the Utah Department of Transportation (UDOT) require a traffic study for the proposed project. The City and UDOT study requirements were met and are provided in this document. A description of the project, existing and background traffic conditions is provided followed by a project trip forecast and distribution for the proposed project. The results of a Level of Service (LOS) analysis are discussed and finally, the findings of the study are summarized and conclusions are provided.

1.1 Purpose and Objective of Study

This study evaluates the potential traffic impacts associated with the proposed Pole Canyon residential/commercial project in Utah County, Utah. Three scenarios were analyzed including:

1. Existing,
2. Background 2023, and
3. Background 2023 plus Full Buildout.

These scenarios were evaluated at four external study intersections, at key intersections located within the proposed project, and at the three external project accesses, where applicable, to determine the potential project-related traffic impacts to the existing transportation network.

1.2 Project Description and Location

The proposed development site is located approximately 1.5 miles south of Cedar Fort City. This area is currently part of the annexation plan of Eagle Mountain City, which is located to the east of the proposed project. Figure 1 illustrates the location of the project in relation to nearby streets and key external intersections. Figure 2 presents the locations of key internal intersections. The site is currently undeveloped however the site surrounds a couple of existing residential developments. The completion of full buildout of the proposed project will include the closure of Wilson Street which is the current access to the White Hills Subdivision. Traffic currently using Wilson Street is expected to use the SR-73/Pole Canyon Boulevard intersection, which will be constructed approximately 750 feet south of the existing SR-73/Wilson Street intersection. The proposed project consists of 8,836 residential units approximately 85 percent are expected to be single family homes, 10 percent townhomes, and 5 percent apartments. 781 units of the 8,836 are contained within the mixed-use component of the development. For this study it was assumed there would be 6,847 single family homes, 806 townhomes and 403 apartment units in the residential part of the development and 664 single family homes, 78 townhomes and 39 apartment units in the mixed-use part of the development. Also included is 595.37 acres of Business Park, 350,000 square feet of commercial space, two proposed Elementary Schools, a boarding school and a Junior High School. Figure 3 shows the concept plan for the Pole Canyon Development.

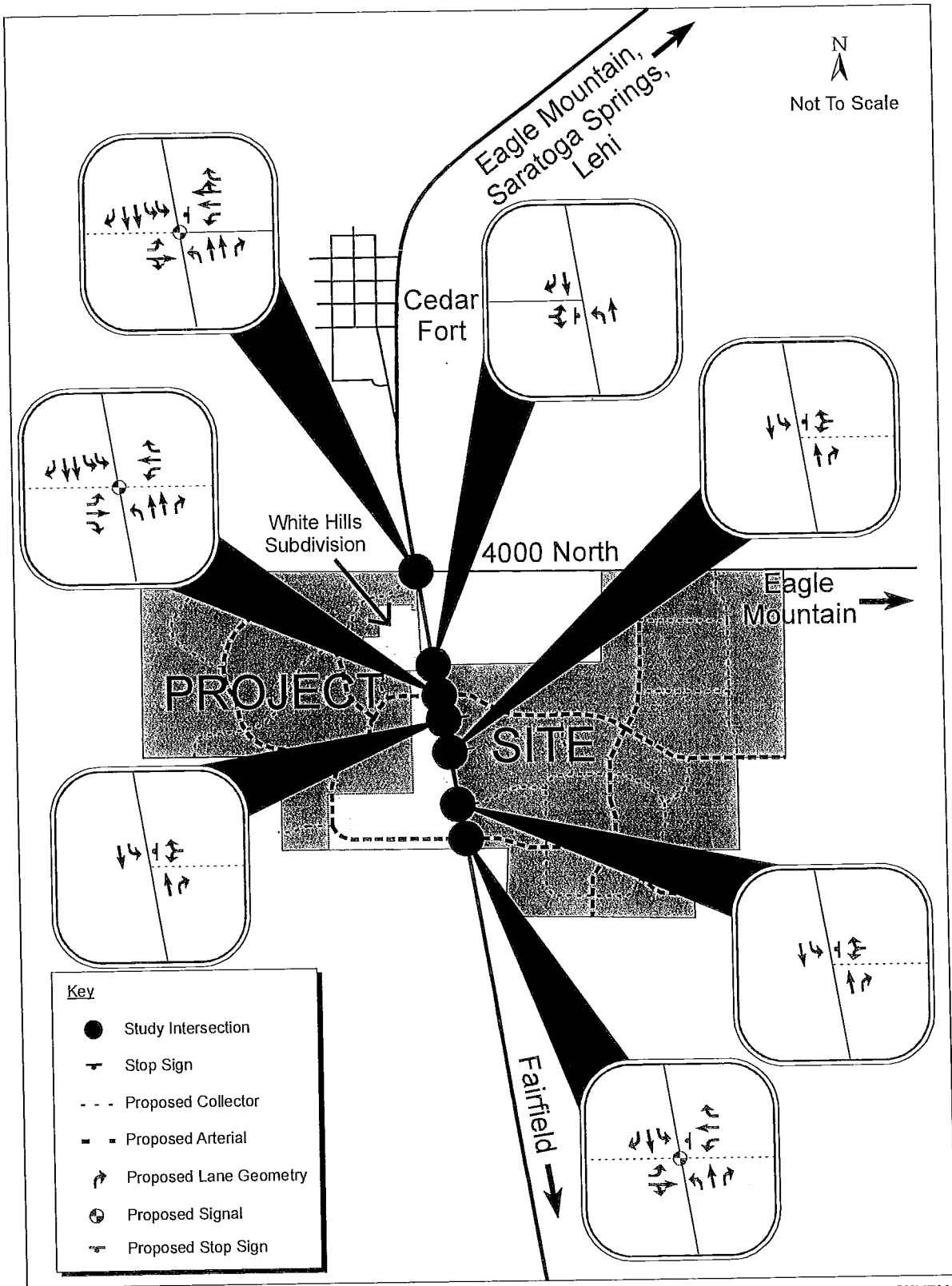

POLE CANYON TRAFFIC IMPACT STUDY

Figure 1
PROJECT VICINITY AND
EXTERNAL STUDY INTERSECTIONS

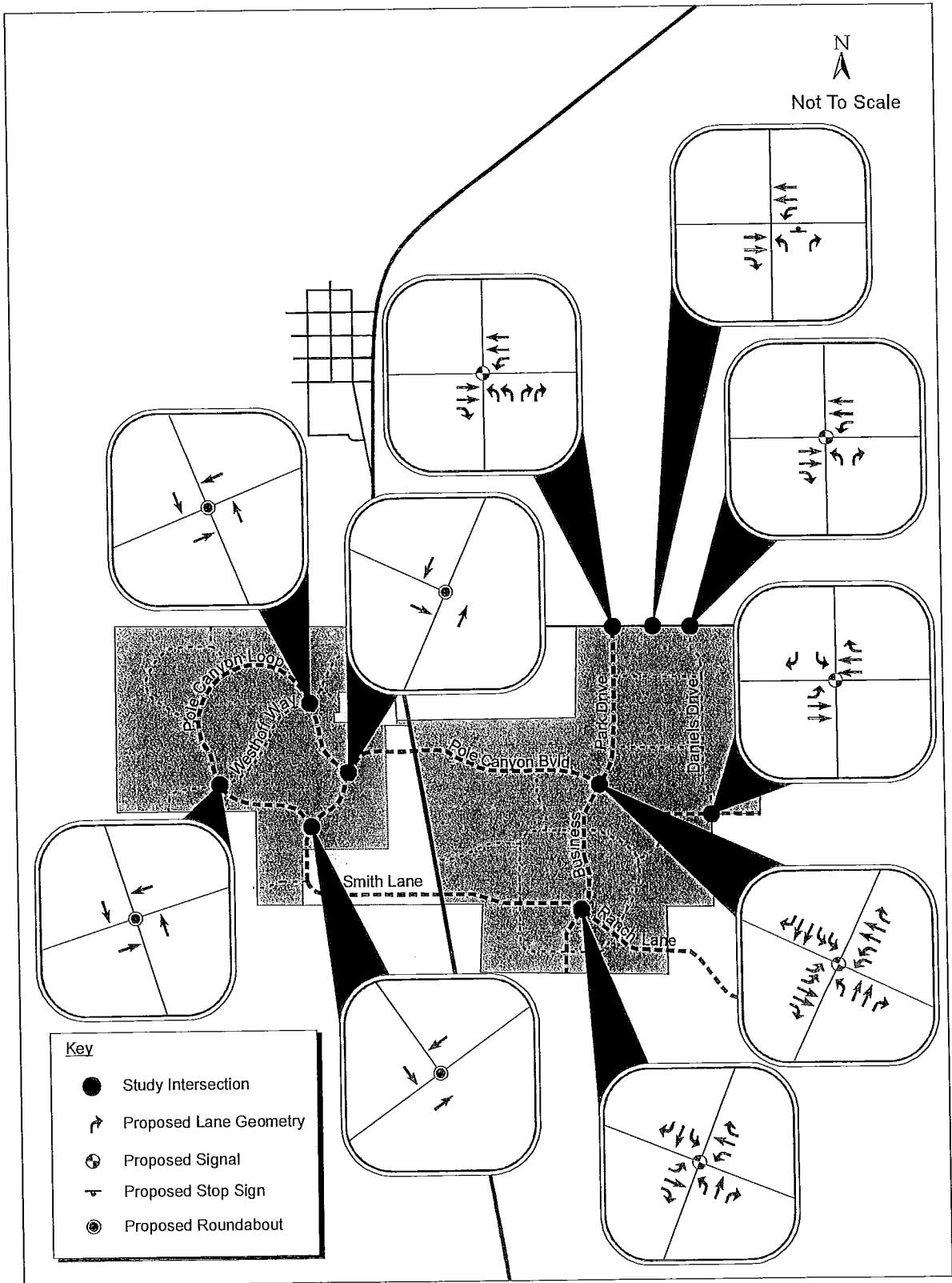

POLE CANYON TRAFFIC IMPACT STUDY

Figure 2
INTERNAL STUDY INTERSECTIONS

Access to the west side of the development will be provided by three intersections, SR-73/4000 North, SR-73/Pole Canyon Boulevard, and SR-73/Ranch Lane. The east side of the project will be accessed using the same three intersections used by the west side with three additional accesses on SR-73, two into the commercial parcel and one between NPA-8 and NPA-9. Access to the entire site from Eagle Mountain will be provided by three arterial roadways, 4000 North, Pole Canyon Boulevard, and Ranch Lane. The proposed project is anticipated to be completed in 2023.

2.0 EXISTING TRAFFIC CONDITIONS

SR-73 is the only major road located near the proposed project. A single lane is provided in each direction on SR-73 with a two-way left turn lane and separate right-turn deceleration lanes at most intersections near the proposed project. The speed limit on SR-73 is posted at 55 miles per hour.

Four study intersections were selected for this study. The SR-73/4000 North, SR-73/Wilson Street, SR-73/Pole Canyon Boulevard, and SR-73/Ranch Lane intersections are all currently unsignalized.

Existing turning movement counts were completed at the SR-73/Wilson Street intersection from 7:00 a.m. to 9:00 a.m. and 4:00 p.m. to 6:00 p.m. on July 10, 2008. Additionally, counts were completed at the SR-73/Eagle Mountain Boulevard intersection located approximately 6 miles from the project site on SR-73 to determine if there was any significant change in traffic volumes passing Cedar Fort. The difference in traffic volumes was found to be insignificant. Detailed count sheets are provided in Appendix A. Figure 4 provides the existing peak hour traffic volumes during the a.m. and p.m. count period.

A 5.8 percent annual growth rate was determined based on 20 years of AADT data collected by UDOT on SR-73. Comparing baseline and future traffic volumes on SR-73 from the regional travel demand model developed by Mountainlands Association of Governments (MAG) yielded an annual growth rate of 2 percent. Due to the relatively low volumes that currently exist on SR-73 there was found to be little difference in the calculated volumes for the two growth rates. The 5.8 percent annual growth rate was applied to the existing traffic volumes for fifteen years to obtain the background 2023 volumes. Figure 5 provides the background 2023 volumes.

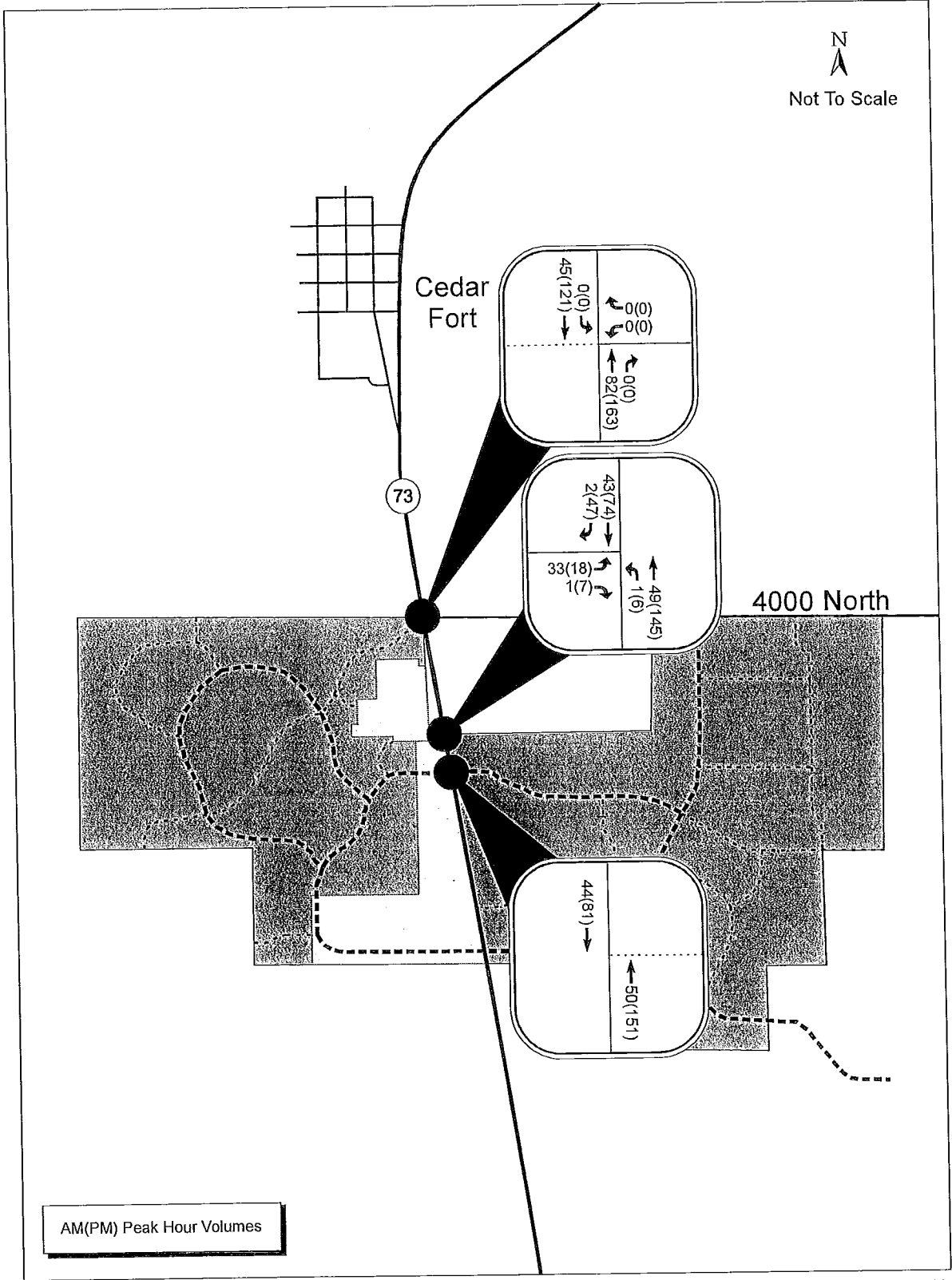

POLE CANYON TRAFFIC IMPACT STUDY

Figure 4
EXISTING 2008 PEAK HOUR TRAFFIC VOLUMES

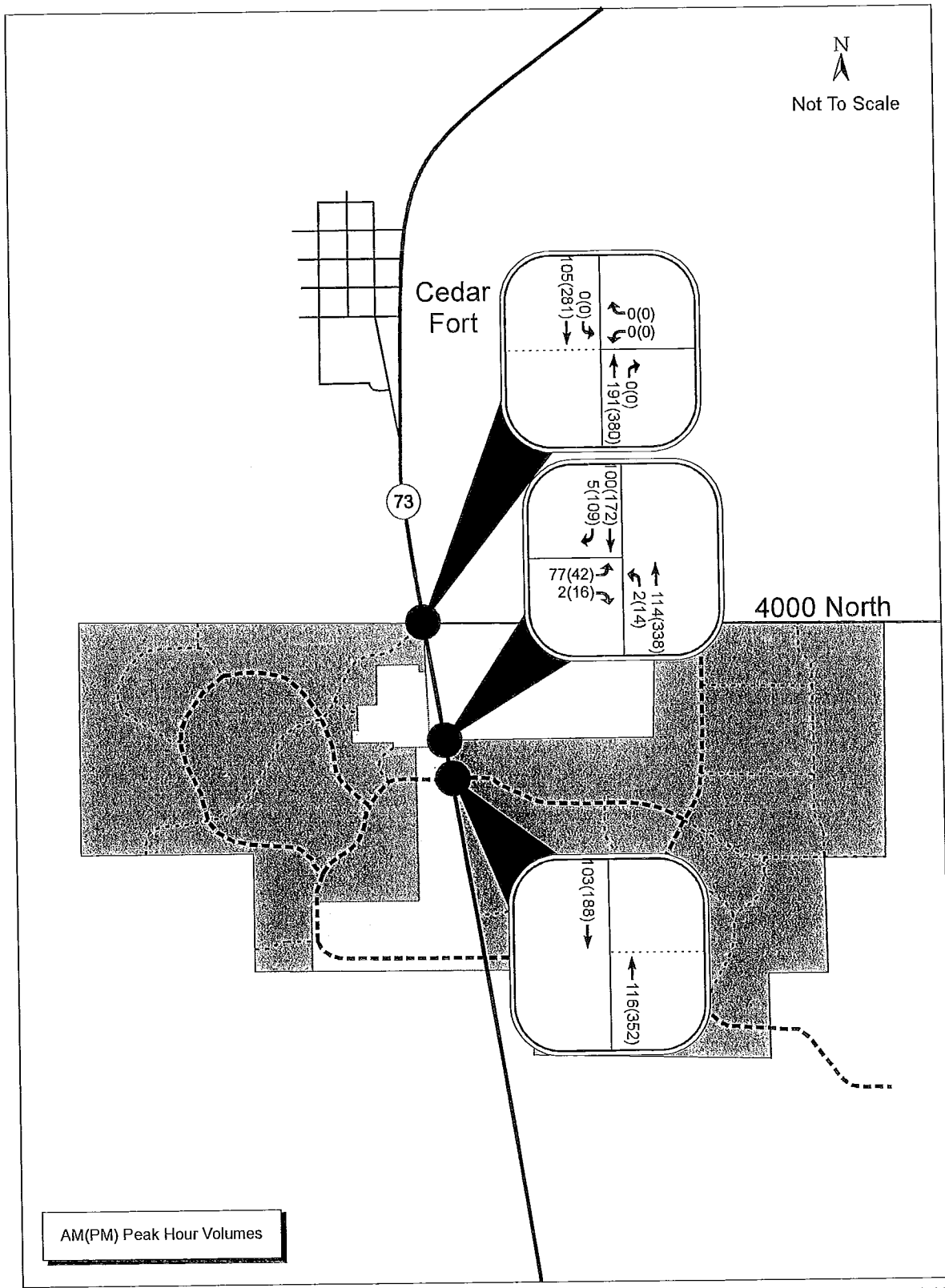

POLE CANYON TRAFFIC IMPACT STUDY

Figure 5
BACKGROUND 2023 PEAK HOUR TRAFFIC VOLUMES

3.0 PROJECT TRAFFIC FORECAST

3.1 Trip Generation

Tables 1, 2, and 3 show the trip generation rates, as well as the number of trips expected to be generated by the business park, residential/school, and mixed-use components, respectively, of the proposed project on a daily and peak hour basis. Table 4 summarizes the totals from Tables 1, 2, and 3 and presents the total project trip generation. A trip generation forecast was completed for the proposed project by using the standard rates for industrial park, single-family homes, apartments, townhomes/condominiums, elementary school, junior high school, medical office, and shopping center from the Institute of Transportation Engineers (ITE) *Trip Generation Manual, 7th Edition* (Land Use Codes 130, 210, 220, 230, 520, 522, 720, and 820 respectively). Peak hour trips were rounded to the nearest whole trip and daily trips were rounded to the nearest ten trips.

Table 1 Business Park Trip Generation Forecast

| Description | AM PEAK HOUR | | | PM PEAK HOUR | | | DAILY |
|----------------------------------------------------------------------|--------------|----------|-------|--------------|----------|-------|--------|
| | Inbound | Outbound | Total | Inbound | Outbound | Total | |
| Rate: Industrial Park Land Use Code 130 (Trips/Acre) | 7.10 | 1.45 | 8.55 | 1.86 | 6.98 | 8.84 | 63.11 |
| Business Park Trips: (595.37 Acres) | 4,227 | 863 | 5,090 | 1,107 | 4,156 | 5,263 | 37,570 |
| Total Business Park Trips: | 4,227 | 863 | 5,090 | 1,107 | 4,156 | 5,263 | 37,570 |

Table 2 Residential/School Trip Generation Forecast

| Description | AM PEAK HOUR | | | PM PEAK HOUR | | | DAILY |
|---------------------------------------------------------------------------------|--------------|----------|-------|--------------|----------|-------|--------|
| | Inbound | Outbound | Total | Inbound | Outbound | Total | |
| Rate: Single Family Home Land Use Code 210 (Trips/Unit) | 0.19 | 0.56 | 0.75 | 0.64 | 0.37 | 1.01 | 9.57 |
| Residential Trips: (6,847 Units) | 1,301 | 3,834 | 5,135 | 4,382 | 2,533 | 6,915 | 65,530 |
| Rate: Apartment Land Use Code 220 (Trips/Unit) | 0.10 | 0.41 | 0.51 | 0.40 | 0.22 | 0.62 | 6.72 |
| Residential Trips: (403 Units) | 40 | 165 | 205 | 161 | 89 | 250 | 2,710 |
| Rate: Townhome/Condominium Land Use Code 230 (Trips/Unit) | 0.07 | 0.37 | 0.44 | 0.35 | 0.17 | 0.52 | 5.86 |
| Residential Trips: (806 Units) | 56 | 298 | 354 | 282 | 137 | 419 | 4,720 |
| Total Residential Trips: | 1,398 | 4,297 | 5,695 | 4,825 | 2,759 | 7,584 | 72,960 |
| Rate: Elementary School Land Use Code 520 (Trips/1000 sq. ft.) | 2.53 | 2.16 | 4.69 | 0.00 | 0.00 | 0.00 | 14.49 |
| School Trips: (110,000 Sq. Ft.) | 278 | 238 | 516 | 0 | 0 | 0 | 1,590 |
| Rate: Junior High School Land Use Code 522 (Trips/1000 sq. ft.) | 2.39 | 1.96 | 4.35 | 0.62 | 0.57 | 1.19 | 13.78 |
| School Trips: (110,000 Sq. Ft.) | 263 | 216 | 479 | 68 | 63 | 131 | 1,520 |
| Total School Trips: | 541 | 453 | 994 | 68 | 63 | 131 | 3,110 |
| Total Residential/ School Trips: | 1,939 | 4,751 | 6,689 | 4,893 | 2,822 | 7,715 | 76,070 |

Table 3 Mixed Use Trip Generation Forecast

| Description | AM PEAK HOUR | | | PM PEAK HOUR | | | DAILY |
|------------------------------------------------------------------------------|--------------|----------|-------|--------------|----------|-------|--------|
| | Inbound | Outbound | Total | Inbound | Outbound | Total | |
| Rate: Single Family Home Land Use Code 210 (Trips/Unit) | 0.19 | 0.56 | 0.75 | 0.64 | 0.37 | 1.01 | 9.57 |
| Residential Trips: (664 Units) | 126 | 372 | 498 | 425 | 246 | 670 | 6,350 |
| Rate: Apartment Land Use Code 220 (Trips/Unit) | 0.10 | 0.41 | 0.51 | 0.40 | 0.22 | 0.62 | 6.72 |
| Residential Trips: (39 Units) | 4 | 16 | 20 | 16 | 9 | 24 | 260 |
| Rate: Townhome/Condominium Land Use Code 230 (Trips/Unit) | 0.07 | 0.37 | 0.44 | 0.35 | 0.17 | 0.52 | 5.86 |
| Residential Trips: (78 Units) | 5 | 29 | 34 | 27 | 13 | 41 | 460 |
| Total Residential Trips: | 136 | 417 | 552 | 468 | 267 | 735 | 7,070 |
| Rate: Medical Office Land Use Code 720 (Trips/1000 sq. ft.) | 1.96 | 0.52 | 2.48 | 1.00 | 2.72 | 3.72 | 36.13 |
| Commercial Trips: (50,000 Sq. Ft.) | 98 | 26 | 124 | 50 | 136 | 186 | 1,810 |
| Rate: Shopping Center Land Use Code 820 (Trips/1000 sq. ft.) | 0.63 | 0.40 | 1.03 | 1.80 | 1.95 | 3.75 | 42.94 |
| Commercial Trips: (300,000 Sq. Ft.) | 189 | 120 | 309 | 540 | 585 | 1,125 | 12,880 |
| Total Commercial Trips: | 287 | 146 | 433 | 590 | 721 | 1,311 | 14,690 |
| Total Mixed Use Trips: | 423 | 563 | 985 | 1,058 | 988 | 2,046 | 21,760 |

Table 4 Trip Generation Forecast Summary

| Description | AM PEAK HOUR | | | PM PEAK HOUR | | | DAILY |
|----------------------------------------------------|--------------|----------|--------|--------------|----------|--------|---------|
| | Inbound | Outbound | Total | Inbound | Outbound | Total | |
| <u>Total Business Park Trips:</u> | 4,227 | 863 | 5,090 | 1,107 | 4,156 | 5,263 | 37,570 |
| <u>Total Residential/ School Trips:</u> | 1,939 | 4,751 | 6,689 | 4,893 | 2,822 | 7,715 | 76,070 |
| <u>Total Mixed Use Trips:</u> | 423 | 563 | 985 | 1,058 | 988 | 2,046 | 21,760 |
| <u>Total Project Trips:</u> | 6,588 | 6,176 | 12,765 | 7,058 | 7,966 | 15,024 | 135,400 |

The project is expected to generate 135,400 daily trips (half inbound and half outbound) with 12,765 trips during the a.m. peak hour (6,588 inbound, and 6,176 outbound) and 15,024 trips during the p.m. peak hour (7,058 inbound, and 7,966 outbound).

3.2 Project Trip Distribution

Project trips were distributed based on existing and anticipated traffic patterns. The general project trip distribution for the residential portion of the project is provided in Figure 6. Figure 7 provides the general trip distribution for the business park and Figure 8 provides the general trips distribution for the mixed-use component. The large percentage of traffic distributed to the east is spread over the three roads that connect to Eagle Mountain. Figure 9 and 10 provide the project traffic volumes at external and internal study intersections, respectively.

Project traffic was added to background traffic to obtain traffic conditions upon completion of full buildout of the project. In the case of the internal study intersections presented in Figure 10 it was assumed that any background traffic using roadways within the project area would be insignificant compared to the volumes generated by the project. Therefore, Figure 10 also represents background 2023 plus full buildout project traffic volumes at internal study intersections. Background 2023 plus full buildout project peak hour traffic volumes at external study intersections are presented in Figure 11.

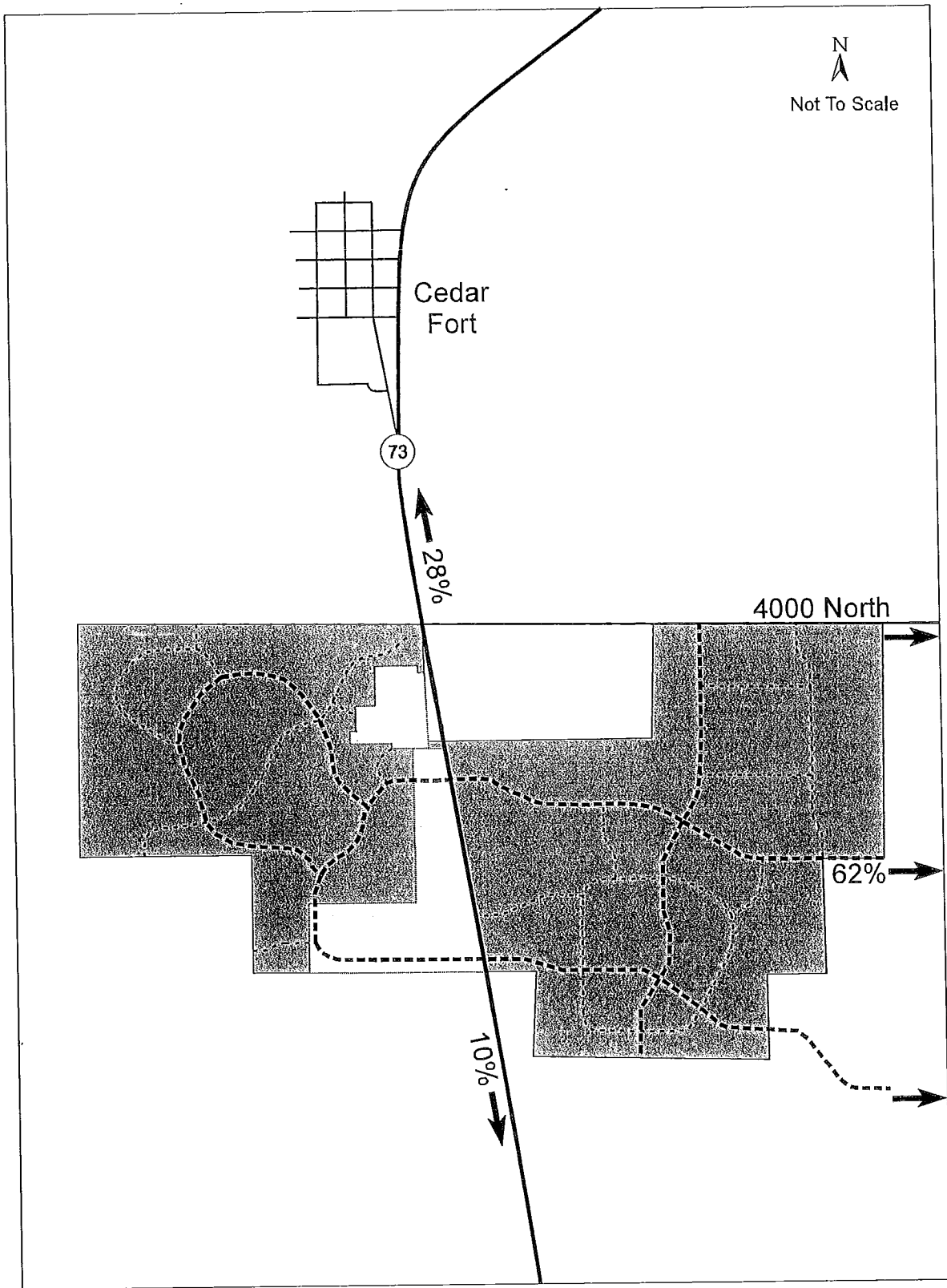

Figure 6
RESIDENTIAL PROJECT TRIP DISTRIBUTION

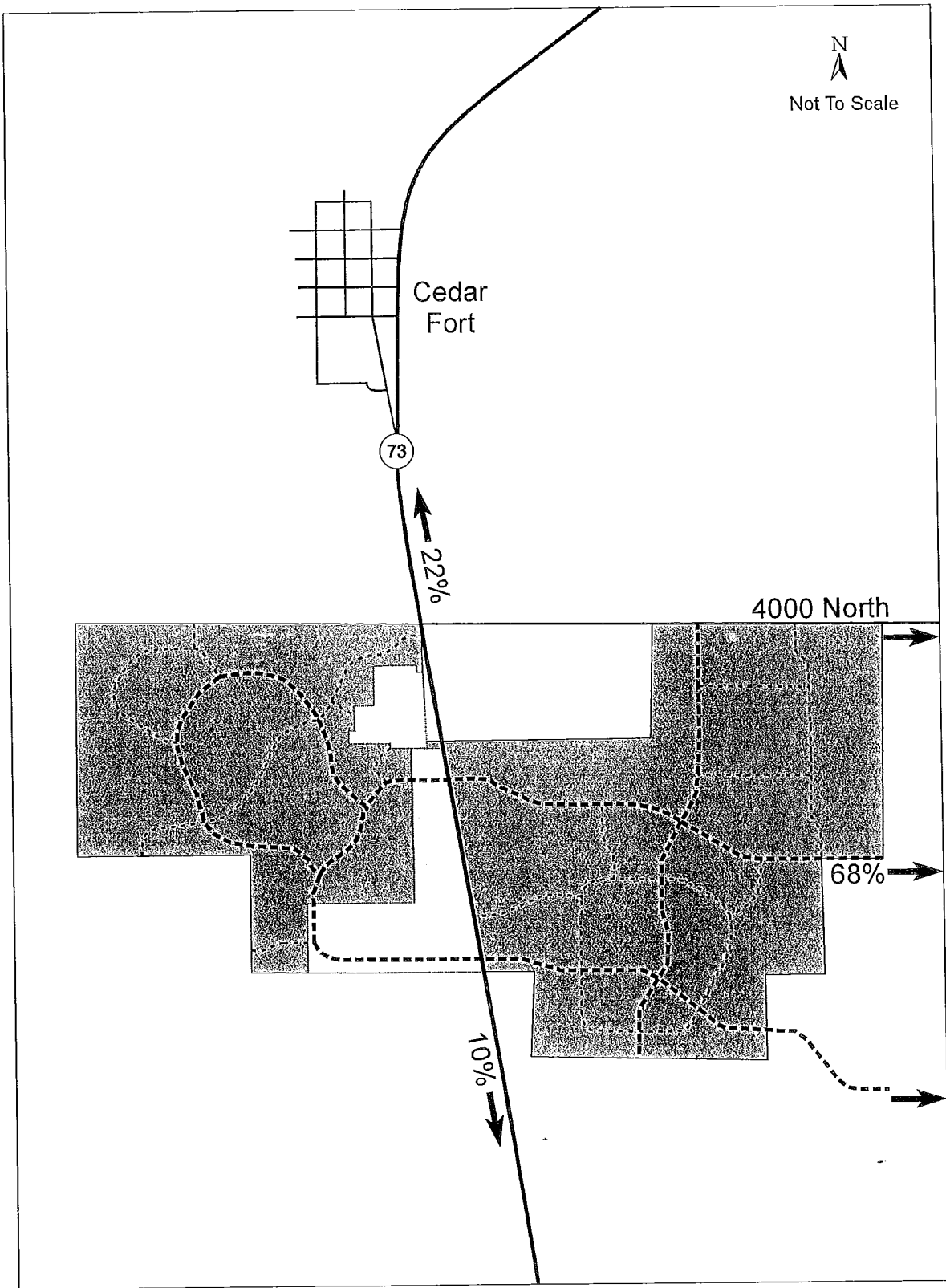

Figure 7
BUSINESS PARK PROJECT TRIP DISTRIBUTION

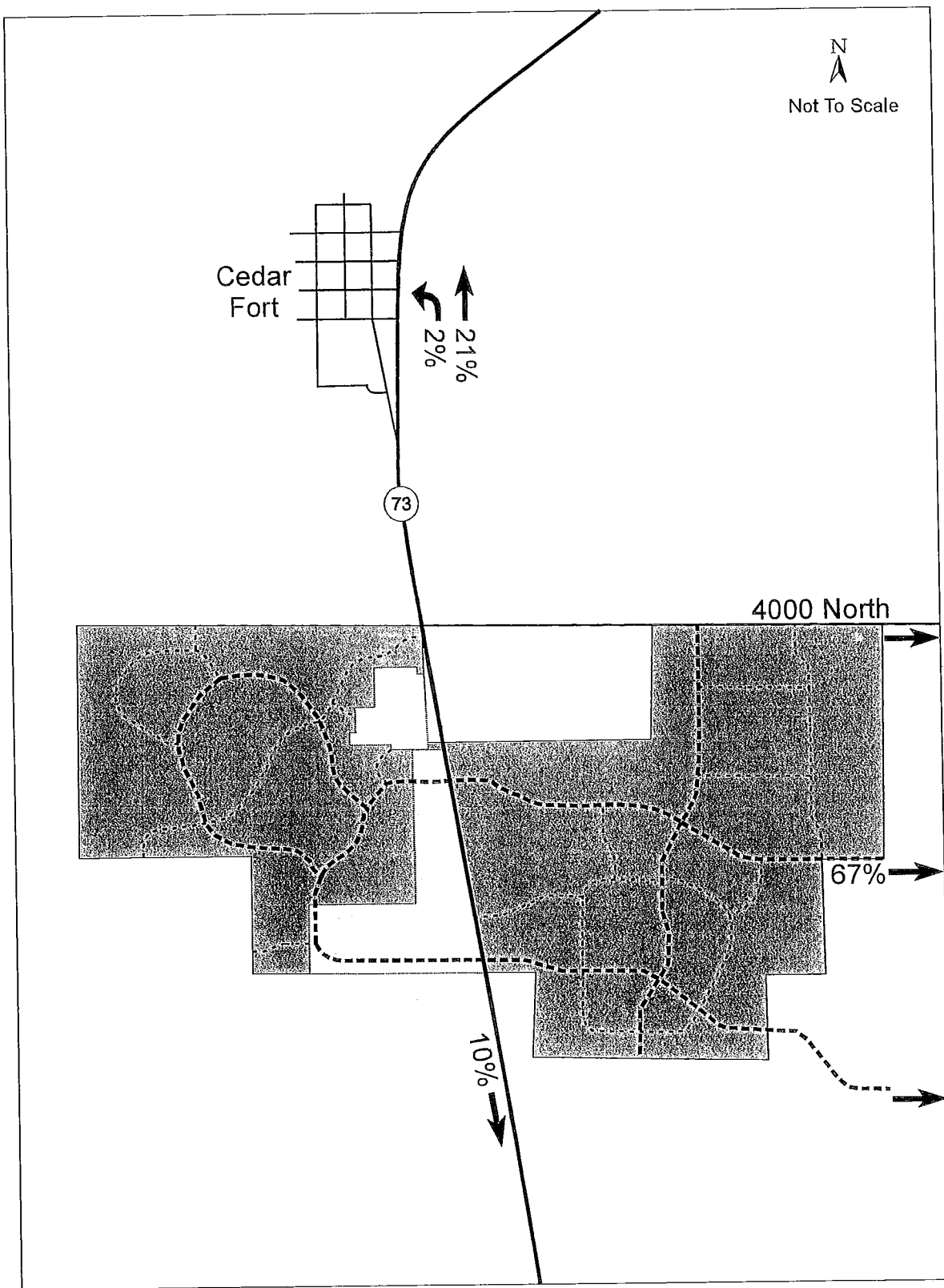

Figure 8
MIXED-USE PROJECT TRIP DISTRIBUTION

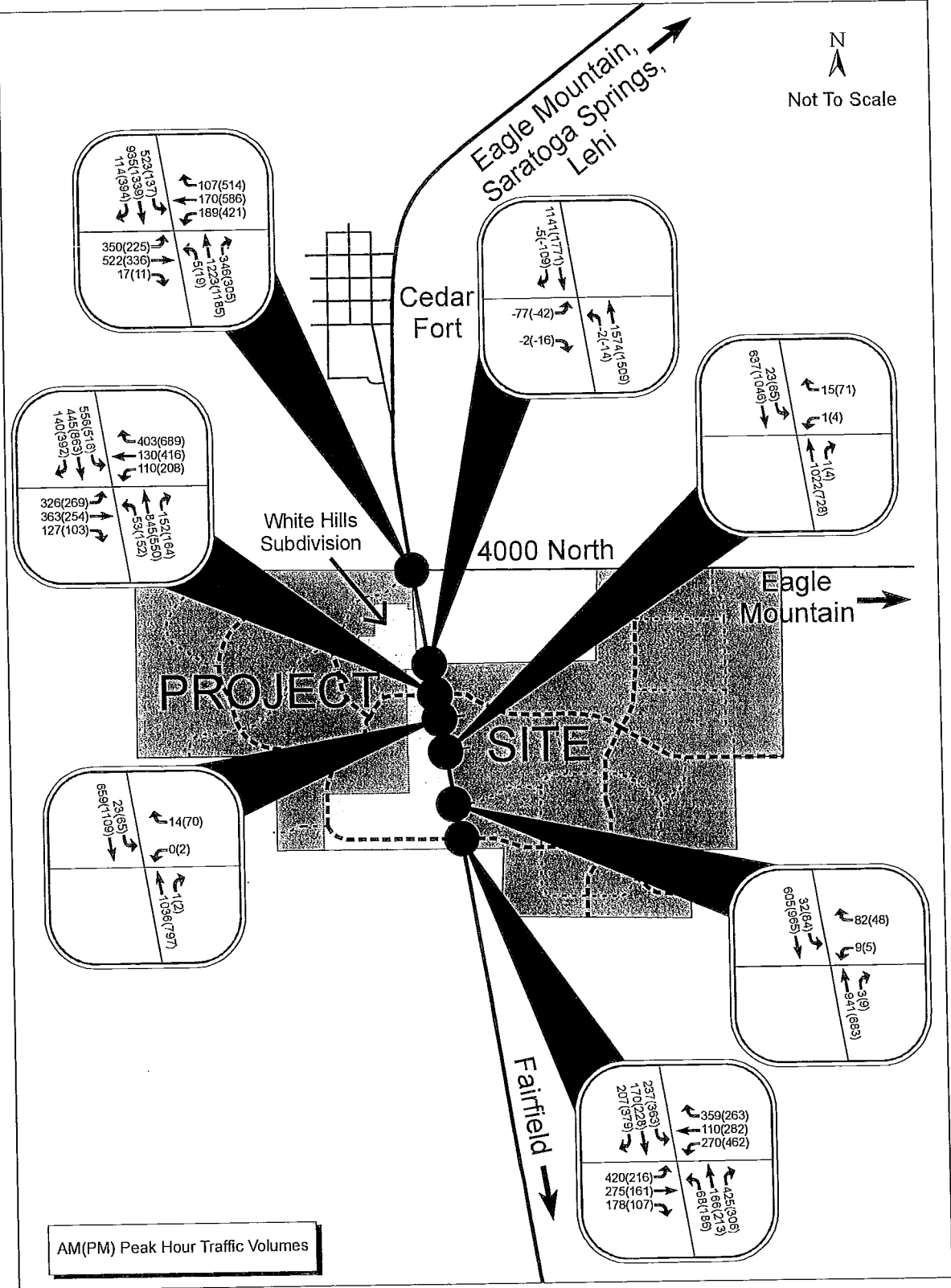

Figure 9
**PROJECT TRAFFIC VOLUMES
 AT EXTERNAL STUDY INTERSECTIONS**

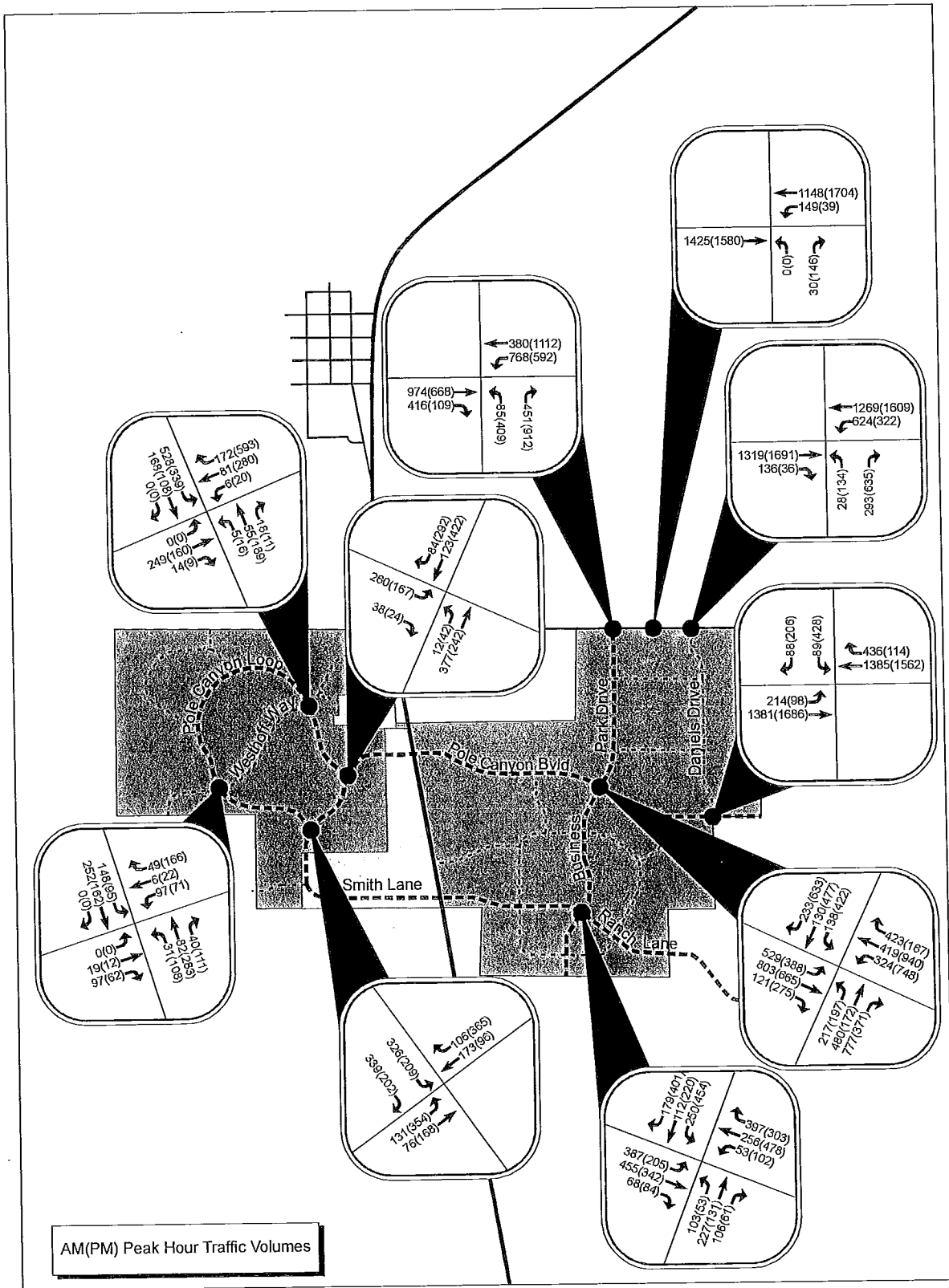

Figure 10
**PROJECT TRAFFIC VOLUMES
 AT INTERNAL STUDY INTERSECTIONS**

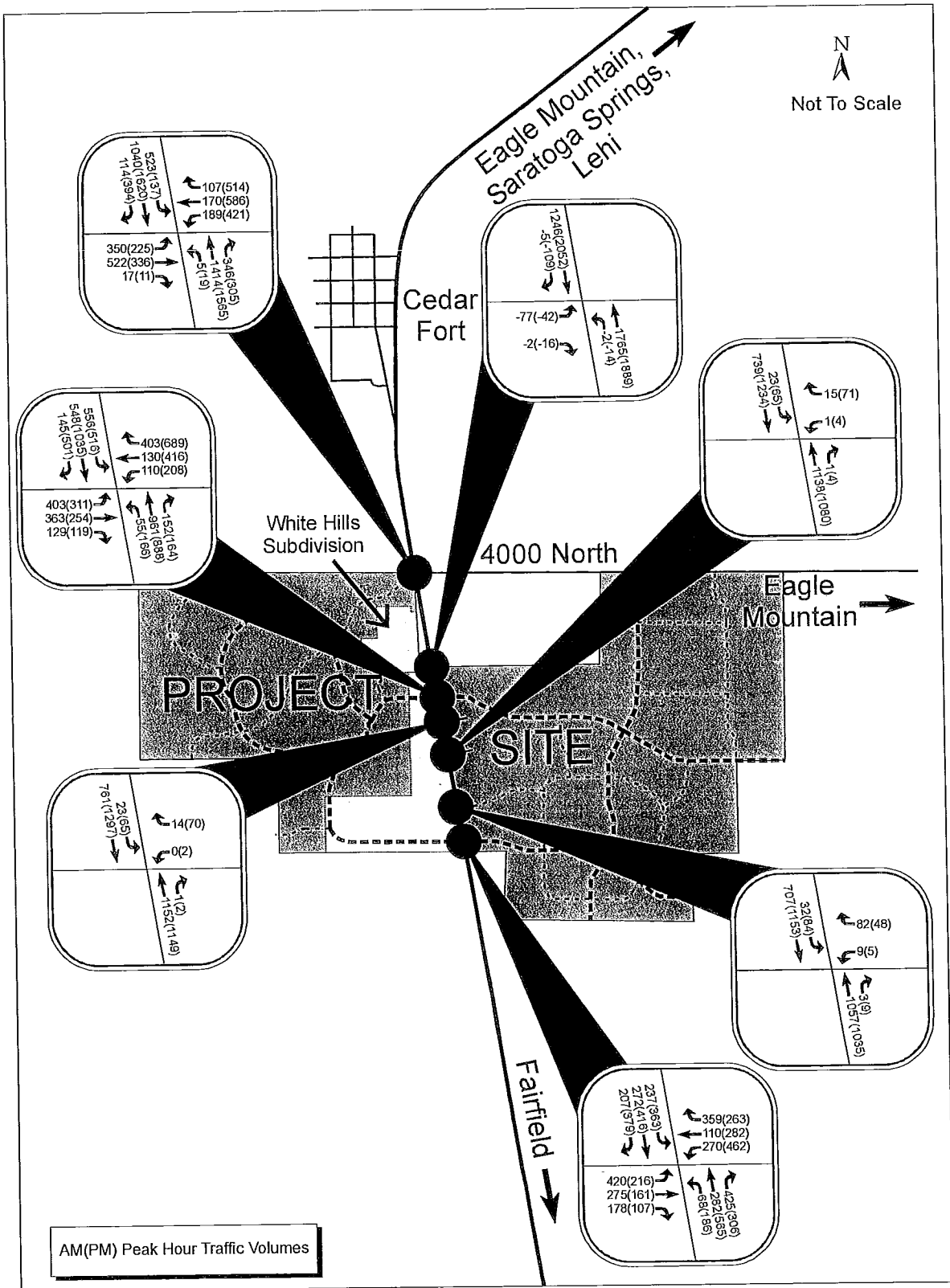

Figure 11
BACKGROUND 2023 PLUS PROJECT TRAFFIC VOLUMES

4.0 LEVEL OF SERVICE ANALYSIS

A level of service (LOS) analysis was completed with Traffix software for the study intersections and project accesses for each of the scenarios as appropriate. A description of the LOS concept and the results of the analysis are provided in this section. Detailed report sheets of all LOS analyses are included in Appendix B.

4.1 Level of Service Concept

LOS is a qualitative measure describing traffic conditions and their perception by motorists. A LOS definition generally describes these conditions in terms of such factors as speed and travel time, freedom to maneuver, traffic interruptions, and delay. There are six levels of service describing these conditions, ranging from A to F, which have been standardized by the Transportation Research Board. LOS A represents a free-flowing traffic condition where motorists are affected very little by other motorists, and the level of comfort and convenience to the motorist is excellent. LOS F is characterized by congested conditions. Motorists have little if any freedom to choose speeds or lanes of travel, and experience discomfort, inconvenience, and long delays. Table 5 presents the delay thresholds for stopped movements at unsignalized intersections and Tables 6 and 7 present the delay thresholds for roundabouts and signalized intersections, respectively.

Table 5 LOS Criteria for Stopped Movements at Unsignalized Intersections

| LEVEL OF SERVICE | CONTROL DELAY PER VEHICLE (in seconds) |
|------------------|----------------------------------------------|
| A | < 10 |
| B | > 10 and < 15 |
| C | > 15 and < 25 |
| D | > 25 and < 35 |
| E | > 35 and < 50 |
| F | > 50 |

Table 6 LOS Criteria for Roundabouts

| LEVEL OF SERVICE | CONTROL DELAY PER VEHICLE (in seconds) |
|------------------|----------------------------------------------|
| A | < 10 |
| B | > 10 and < 15 |
| C | > 15 and < 25 |
| D | > 25 and < 35 |
| E | > 35 and < 50 |
| F | > 50 |

Table 7 LOS Criteria for Signalized Intersections

| LEVEL OF SERVICE | CONTROL DELAY PER VEHICLE (in seconds) |
|------------------|----------------------------------------|
| A | < 10 |
| B | > 10 and < 20 |
| C | > 20 and < 35 |
| D | > 35 and < 55 |
| E | > 55 and < 80 |
| F | > 80 |

4.2 Results of LOS Analysis

The results of the LOS analysis for existing, background and project scenarios at the external study intersections are provided in Table 8 and Table 9 provides the results of the LOS analysis for all internal study intersections. The average delay, along with the LOS letter designation is provided for all signalized and roundabout study intersections. For all stop controlled study intersections, the stopped movement delay, along with the LOS letter designation is provided.

Table 8 External Intersection Peak Hour LOS Summary

| Intersection | Approach | Existing | | | | 2023 Background | | | | 2023 Background plus Full Buildout Project | | | |
|------------------------------|----------------------|---------------|-----|---------------|-----|-----------------|-----|---------------|-----|--------------------------------------------|-----|---------------|-----|
| | | AM | | PM | | AM | | PM | | AM | | PM | |
| | | Delay (s/veh) | LOS | Delay (s/veh) | LOS | Delay (s/veh) | LOS | Delay (s/veh) | LOS | Delay (s/veh) | LOS | Delay (s/veh) | LOS |
| SR-73/ 4000 North | Intersection Average | -- | -- | -- | -- | -- | -- | -- | -- | 24.2 | C | 20.2 | C |
| SR-73/ Wilson Street | Eastbound | 9.1 | A | 9.6 | A | 10.2 | B | 12.0 | B | -- | -- | -- | -- |
| SR-73/ Pole Canyon Boulevard | Intersection Average | -- | -- | -- | -- | -- | -- | -- | -- | 16.9 | B | 20.5 | C |
| SR-73/ Commercial Access #1 | Westbound | -- | -- | -- | -- | -- | -- | -- | -- | 20.7 | C | 29.1 | D |
| SR-73/ Commercial Access #2 | Westbound | -- | -- | -- | -- | -- | -- | -- | -- | 22.7 | C | 29.0 | D |
| SR-73/ Residential Access | Westbound | -- | -- | -- | -- | -- | -- | -- | -- | 26.5 | D | 29.7 | D |
| SR-73/ Ranch Lane | Intersection Average | -- | -- | -- | -- | -- | -- | -- | -- | 15.7 | B | 23.4 | C |

Table 9 Internal Intersection Peak Hour LOS Summary

| Intersection | Approach | 2023 Background plus Full Buildout Project | | | |
|-----------------------------------------------|-------------------------|--------------------------------------------|-----|---------------|-----|
| | | AM | | PM | |
| | | Delay (s/veh) | LOS | Delay (s/veh) | LOS |
| Westhoff Way/ Pole Canyon Loop South | Roundabout | 4.4 | A | 5.0 | A |
| Westhoff Way/ Pole Canyon Loop North | Roundabout | 6.6 | A | 11.1 | B |
| Smith Lane/ Pole Canyon Loop | Roundabout | 6.5 | A | 6.0 | A |
| Pole Canyon Boulevard/ PoleCanyon Loop | Roundabout | 4.6 | A | 6.4 | A |
| 4000 North/ Business Park Drive | Intersection Average | 20.8 | C | 16.2 | B |
| 4000 North/ Business Access #1 | Northbound | 15.7 | C | 23.6 | C |
| 4000 North/ Daniels Drive | Intersection Average | 16.3 | B | 33.1 | C |
| Pole Canyon Boulevard/ Daniels Drive | Intersection Average | 2.8 | A | 8.9 | A |
| Pole Canyon Boulevard/ Business Park Drive | Intersection Average | 27.1 | C | 27.0 | C |
| Ranch Lane/ Business Park Drive | Intersection Average | 9.9 | A | 11.8 | B |

The existing volumes along SR-73 are relatively low and the traffic volumes currently utilizing 4000 North were assumed to be even lower, therefore the SR-73/4000 North intersection was not analyzed for existing and background scenarios. It is expected that the stopped movements at this intersection experience little to no delay and operate at LOS A under existing conditions. With the addition of project traffic it is anticipated that this intersection will operate at LOS C as a signalized intersection during the a.m. and p.m. peak hours. All stopped movements at the SR-73/Wilson Street intersection currently operate at LOS A and by 2023 are expected to operate at LOS B. At full buildout this intersection is expected to be closed and will therefore have no delay.

All stopped controlled external study intersections are expected to operate at LOS D or better during both the a.m. and p.m. peak hours. The SR-73/Pole Canyon Boulevard and SR-73/Ranch Lane intersections are both expected to operate at LOS B during the a.m. peak hour and LOS C during the p.m. peak hour at full buildout of the proposed project.

All proposed roundabouts are expected to operate at LOS B or better, all proposed signalized intersections within the project are expected to operate at LOS C or better, and all stop controlled intersections are expected to operate at LOS C or better during both peak hours.

5.0 RECOMMENDATIONS

The proposed project will require that a total of three traffic signals be installed along SR-73 within the project vicinity. These signals are to be located at the three proposed major arterial roads which are 4000 North, Pole Canyon Boulevard and Ranch Lane. The spacing between these signals is approximately half a mile. These signals should all be equipped with protected and protected-permitted left turn phasing.

It is also recommended that SR-73 be widened to two lanes each direction across 4000 North and Pole Canyon Boulevard. SR-73 could then be tapered down to a single lane each direction north of 4000 North and South of Pole Canyon Boulevard. Dual left turn lanes should be added on SR-73 on the southbound approach at 4000 North and Pole Canyon Boulevard. The westbound approach at the SR-73/4000 North intersection should have a separate right-turn, a through-right, a through and a separate left-turn lane on the westbound approach. All other approaches at the SR-73/4000 North and SR-73/Pole Canyon Boulevard intersections should include separate right and left-turn lanes and a single through lane in all directions. All turning movements onto SR-73 require acceleration lanes.

The SR-73/Ranch Lane intersection should include separate right and left-turn lanes and a single through lane in all directions except the eastbound approach which would have a right-through lane instead of two separate lanes. All stop controlled approaches onto SR-73 should have separate right and left-turn lanes and acceleration/deceleration lanes on SR-73. See Figure 1 for all external study intersection proposed lane geometry.

Within the proposed project a total of 5 traffic signals will be required; two on 4000 North at Business Park Drive and Daniels Drive, two on Pole Canyon Boulevard at Business Park Drive and Daniels Drive, and one on Ranch Lane at Pole Canyon Boulevard. All signalized internal study intersections should be equipped with protected and protected permitted left turn phasing except the Ranch Lane/Business Park Drive intersection.

East of SR-73, 4000 North should be paved and widened to 2 lanes each direction within the project vicinity. Pole Canyon Boulevard and Business Park Drive should have 2 lanes in either direction with a center left-turn lane. Ranch Lane should have a single lane in each direction with a center left-turn lane.

West of SR-73 all roads are expected to function well with a single lane in each direction and auxiliary lanes as necessary. See Figure 2 for proposed lane geometry at all internal study intersections

6.0 SUMMARY AND CONCLUSIONS

- ▶ The project is expected to generate 135,400 daily trips (half inbound and half outbound) with 12,765 trips during the a.m. peak hour (6,588 inbound, and 6,176 outbound) and 15,024 trips during the p.m. peak hour (7,058 inbound, and 7,966 outbound).
- ▶ The SR-73/4000 North intersection is anticipated to operate at LOS B during the a.m. peak hour and LOS C during the p.m. peak hour with the addition of project traffic and the installation of a traffic signal.

- ▶ All stopped movements at the SR-73/Wilson Street intersection currently operate at LOS A and by 2023 are expected to operate at LOS B. At full buildout this intersection is expected to be closed and will therefore have no delay.
- ▶ The SR-73/Pole Canyon Boulevard and SR-73/Ranch Lane intersections are both expected to operate at LOS B during the a.m. peak hour and LOS C during the p.m. peak hour at full buildout of the proposed project and with the installation of a traffic signal.
- ▶ All stopped controlled external study intersections are expected to operate at LOS D or better during both the a.m. and p.m. peak hours.
- ▶ All proposed roundabouts are expected to operate at LOS B or better, all proposed signalized intersections within the project are expected to operate at LOS C or better, and all internal stop controlled intersections are expected to operate at LOS C or better during both peak hours.

Appendix A Turning Movement Counts

DMJM Harris
935 E. South Union Avenue Suite D-203
Midvale, UT 84047

File Name : Wilson St & SR-73
Site Code : 00000000
Start Date : 7/10/2008
Page No : 1

Default Comments
Change These in The Preferences Window
Select File/Preference in the Main Scree
Then Click the Comments Tab

Groups Printed- Vehicles - Trucks

| Start Time | SR-73 Southbound | | | | | Westbound | | | | | SR-73 Northbound | | | | | Wilson Street Eastbound | | | | | Int. Total |
|---------------|------------------|------|------|------|------------|-----------|------|------|------|------------|------------------|------|------|------|------------|-------------------------|------|------|------|------------|------------|
| | Right | Thru | Left | Peds | App. Total | Right | Thru | Left | Peds | App. Total | Right | Thru | Left | Peds | App. Total | Right | Thru | Left | Peds | App. Total | |
| 07:00 AM | 0 | 12 | 0 | 0 | 12 | 0 | 0 | 0 | 0 | 0 | 0 | 16 | 0 | 0 | 16 | 0 | 0 | 8 | 0 | 8 | 36 |
| 07:15 AM | 1 | 12 | 0 | 0 | 13 | 0 | 0 | 0 | 0 | 0 | 0 | 11 | 0 | 0 | 11 | 1 | 0 | 12 | 0 | 13 | 37 |
| 07:30 AM | 0 | 11 | 0 | 0 | 11 | 0 | 0 | 0 | 0 | 0 | 0 | 13 | 0 | 0 | 13 | 0 | 0 | 5 | 0 | 5 | 29 |
| 07:45 AM | 1 | 8 | 0 | 0 | 9 | 0 | 0 | 0 | 0 | 0 | 0 | 9 | 1 | 0 | 10 | 0 | 0 | 8 | 0 | 8 | 27 |
| Total | 2 | 43 | 0 | 0 | 45 | 0 | 0 | 0 | 0 | 0 | 0 | 49 | 1 | 0 | 50 | 1 | 0 | 33 | 0 | 34 | 129 |
| 08:00 AM | 0 | 17 | 0 | 0 | 17 | 0 | 0 | 0 | 0 | 0 | 0 | 5 | 0 | 0 | 5 | 1 | 0 | 7 | 0 | 8 | 30 |
| 08:15 AM | 6 | 20 | 0 | 0 | 26 | 0 | 0 | 0 | 0 | 0 | 0 | 9 | 0 | 0 | 9 | 0 | 0 | 6 | 0 | 6 | 41 |
| 08:30 AM | 2 | 14 | 0 | 0 | 16 | 0 | 0 | 0 | 0 | 0 | 0 | 3 | 0 | 0 | 3 | 0 | 0 | 4 | 0 | 4 | 23 |
| 08:45 AM | 1 | 9 | 0 | 0 | 10 | 0 | 0 | 0 | 0 | 0 | 0 | 12 | 0 | 0 | 12 | 1 | 0 | 4 | 0 | 5 | 27 |
| Total | 9 | 60 | 0 | 0 | 69 | 0 | 0 | 0 | 0 | 0 | 0 | 29 | 0 | 0 | 29 | 2 | 0 | 21 | 0 | 23 | 121 |
| *** BREAK *** | | | | | | | | | | | | | | | | | | | | | |
| 04:00 PM | 7 | 16 | 0 | 0 | 23 | 0 | 0 | 0 | 0 | 0 | 0 | 22 | 0 | 0 | 22 | 2 | 0 | 2 | 0 | 4 | 49 |
| 04:15 PM | 13 | 13 | 0 | 0 | 26 | 0 | 0 | 0 | 0 | 0 | 0 | 12 | 1 | 0 | 13 | 1 | 0 | 3 | 0 | 4 | 43 |
| 04:30 PM | 4 | 11 | 0 | 0 | 15 | 0 | 0 | 0 | 0 | 0 | 0 | 24 | 1 | 0 | 25 | 2 | 0 | 0 | 0 | 2 | 42 |
| 04:45 PM | 9 | 16 | 0 | 0 | 25 | 0 | 0 | 0 | 0 | 0 | 0 | 38 | 1 | 0 | 39 | 2 | 0 | 5 | 0 | 7 | 71 |
| Total | 33 | 56 | 0 | 0 | 89 | 0 | 0 | 0 | 0 | 0 | 0 | 96 | 3 | 0 | 99 | 7 | 0 | 10 | 0 | 17 | 205 |
| 05:00 PM | 10 | 27 | 0 | 0 | 37 | 0 | 0 | 0 | 0 | 0 | 0 | 40 | 4 | 0 | 44 | 0 | 0 | 5 | 0 | 5 | 86 |
| 05:15 PM | 12 | 15 | 0 | 0 | 27 | 0 | 0 | 0 | 0 | 0 | 0 | 41 | 1 | 0 | 42 | 2 | 0 | 2 | 0 | 4 | 73 |
| 05:30 PM | 16 | 16 | 0 | 0 | 32 | 0 | 0 | 0 | 0 | 0 | 0 | 26 | 0 | 0 | 26 | 3 | 0 | 6 | 0 | 9 | 67 |
| 05:45 PM | 12 | 15 | 0 | 0 | 27 | 0 | 0 | 0 | 0 | 0 | 0 | 13 | 1 | 0 | 14 | 0 | 0 | 11 | 0 | 11 | 52 |
| Total | 50 | 73 | 0 | 0 | 123 | 0 | 0 | 0 | 0 | 0 | 0 | 120 | 6 | 0 | 126 | 5 | 0 | 24 | 0 | 29 | 278 |
| Grand Total | 94 | 232 | 0 | 0 | 326 | 0 | 0 | 0 | 0 | 0 | 0 | 294 | 10 | 0 | 304 | 15 | 0 | 88 | 0 | 103 | 733 |
| Apprch % | 28.8 | 71.2 | 0 | 0 | | 0 | 0 | 0 | 0 | | 0 | 96.7 | 3.3 | 0 | | 14.6 | 0 | 85.4 | 0 | | |
| Total % | 12.8 | 31.7 | 0 | 0 | 44.5 | 0 | 0 | 0 | 0 | | 0 | 40.1 | 1.4 | 0 | 41.5 | 2 | 0 | 12 | 0 | 14.1 | |
| Vehicles | 93 | 229 | 0 | 0 | 322 | 0 | 0 | 0 | 0 | 0 | 0 | 284 | 10 | 0 | 294 | 15 | 0 | 88 | 0 | 103 | 719 |
| % Vehicles | 98.9 | 98.7 | 0 | 0 | 98.8 | 0 | 0 | 0 | 0 | 0 | 0 | 96.6 | 100 | 0 | 96.7 | 100 | 0 | 100 | 0 | 100 | 98.1 |
| Trucks | 1 | 3 | 0 | 0 | 4 | 0 | 0 | 0 | 0 | 0 | 0 | 10 | 0 | 0 | 10 | 0 | 0 | 0 | 0 | 0 | 14 |
| % Trucks | 1.1 | 1.3 | 0 | 0 | 1.2 | 0 | 0 | 0 | 0 | 0 | 0 | 3.4 | 0 | 0 | 3.3 | 0 | 0 | 0 | 0 | 0 | 1.9 |

DMJM Harris

935 E. South Union Avenue Suite D-203
Midvale, UT 84047

Default Comments
Change These in The Preferences Window
Select File/Preference in the Main Scree
Then Click the Comments Tab

File Name : Wilson St & SR-73
Site Code : 00000000
Start Date : 7/10/2008
Page No : 2

| Start Time | SR-73 Southbound | | | | | Westbound | | | | | SR-73 Northbound | | | | | Wilson Street Eastbound | | | | | Int. Total |
|------------------------------------------------------------|------------------|------|------|------|------------|-----------|------|------|------|------------|------------------|------|------|------|------------|-------------------------|------|------|------|------------|------------|
| | Right | Thru | Left | Peds | App. Total | Right | Thru | Left | Peds | App. Total | Right | Thru | Left | Peds | App. Total | Right | Thru | Left | Peds | App. Total | |
| Peak Hour Analysis From 07:00 AM to 11:45 AM - Peak 1 of 1 | | | | | | | | | | | | | | | | | | | | | |
| Peak Hour for Entire Intersection Begins at 07:00 AM | | | | | | | | | | | | | | | | | | | | | |
| 07:00 AM | 0 | 12 | 0 | 0 | 12 | 0 | 0 | 0 | 0 | 0 | 0 | 16 | 0 | 0 | 16 | 0 | 0 | 8 | 0 | 8 | 36 |
| 07:15 AM | 1 | 12 | 0 | 0 | 13 | 0 | 0 | 0 | 0 | 0 | 0 | 11 | 0 | 0 | 11 | 1 | 0 | 12 | 0 | 13 | 37 |
| 07:30 AM | 0 | 11 | 0 | 0 | 11 | 0 | 0 | 0 | 0 | 0 | 0 | 13 | 0 | 0 | 13 | 0 | 0 | 5 | 0 | 5 | 29 |
| 07:45 AM | 1 | 8 | 0 | 0 | 9 | 0 | 0 | 0 | 0 | 0 | 0 | 9 | 1 | 0 | 10 | 0 | 0 | 8 | 0 | 8 | 27 |
| Total Volume | 2 | 43 | 0 | 0 | 45 | 0 | 0 | 0 | 0 | 0 | 0 | 49 | 1 | 0 | 50 | 1 | 0 | 33 | 0 | 34 | 129 |
| % App. Total | 4.4 | 95.6 | 0 | 0 | | 0 | 0 | 0 | 0 | | 0 | 98 | 2 | 0 | | 2.9 | 0 | 97.1 | 0 | | |
| PHF | .500 | .896 | .000 | .000 | .865 | .000 | .000 | .000 | .000 | .000 | .000 | .766 | .250 | .000 | .781 | .250 | .000 | .688 | .000 | .654 | .872 |

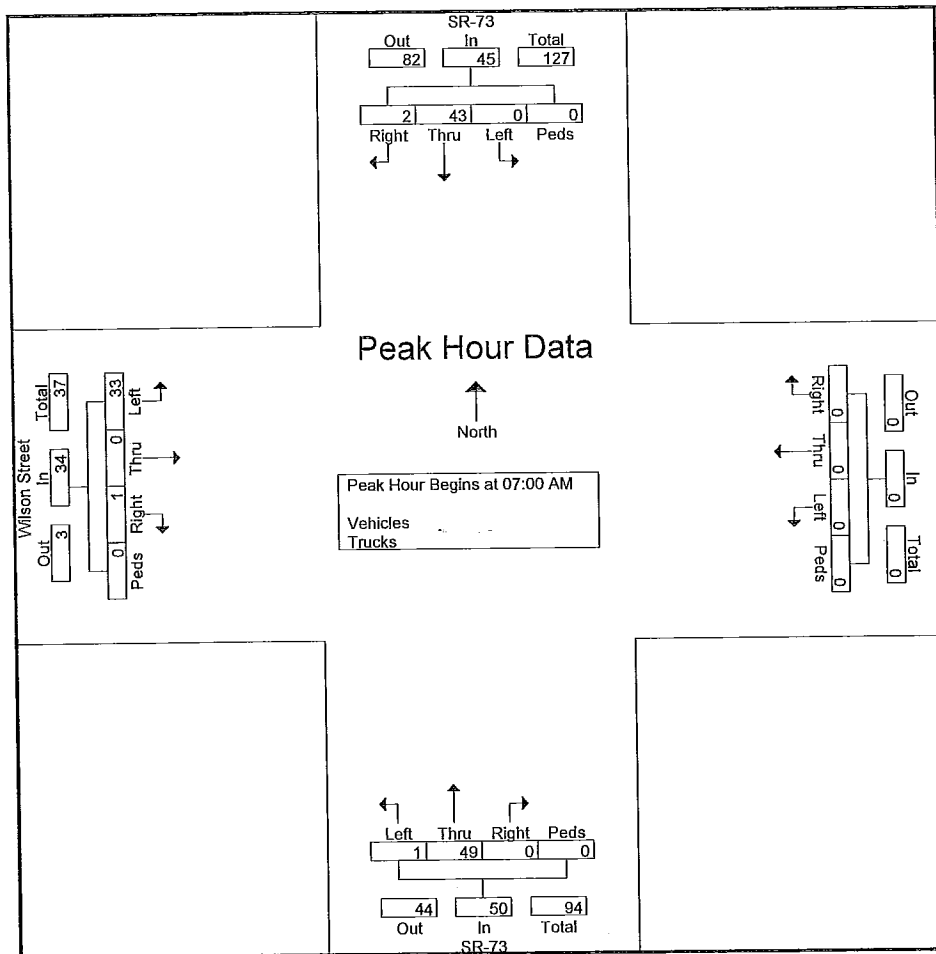

DMJM Harris

935 E. South Union Avenue Suite D-203
Midvale, UT 84047

Default Comments
Change These in The Preferences Window
Select File/Preference in the Main Scree
Then Click the Comments Tab

File Name : Wilson St & SR-73
Site Code : 00000000
Start Date : 7/10/2008
Page No : 3

| Start Time | SR-73 Southbound | | | | | Westbound | | | | | SR-73 Northbound | | | | | Wilson Street Eastbound | | | | | Int. Total |
|------------------------------------------------------------|------------------|-------|------|-------|------------|-----------|-------|------|-------|------------|------------------|-------|------|------|------------|-------------------------|-------|------|------|------------|------------|
| | Rig ht | Thr u | Left | Ped s | App. Total | Rig ht | Thr u | Left | Ped s | App. Total | Right | Thr u | Left | Peds | App. Total | Right | Thr u | Left | Peds | App. Total | |
| Peak Hour Analysis From 12:00 PM to 05:45 PM - Peak 1 of 1 | | | | | | | | | | | | | | | | | | | | | |
| Peak Hour for Entire Intersection Begins at 04:45 PM | | | | | | | | | | | | | | | | | | | | | |
| 04:45 PM | 9 | 16 | 0 | 0 | 25 | 0 | 0 | 0 | 0 | 0 | 0 | 38 | 1 | 0 | 39 | 2 | 0 | 5 | 0 | 7 | 71 |
| 05:00 PM | 10 | 27 | 0 | 0 | 37 | 0 | 0 | 0 | 0 | 0 | 0 | 40 | 4 | 0 | 44 | 0 | 0 | 5 | 0 | 5 | 86 |
| 05:15 PM | 12 | 15 | 0 | 0 | 27 | 0 | 0 | 0 | 0 | 0 | 0 | 41 | 1 | 0 | 42 | 2 | 0 | 2 | 0 | 4 | 73 |
| 05:30 PM | 16 | 16 | 0 | 0 | 32 | 0 | 0 | 0 | 0 | 0 | 0 | 26 | 0 | 0 | 26 | 3 | 0 | 6 | 0 | 9 | 67 |
| Total Volume | 47 | 74 | 0 | 0 | 121 | 0 | 0 | 0 | 0 | 0 | 0 | 145 | 6 | 0 | 151 | 7 | 0 | 18 | 0 | 25 | 297 |
| % App. Total | 38.8 | 61.2 | 0 | 0 | | 0 | 0 | 0 | 0 | | 0 | 96 | 4 | 0 | | 28 | 0 | 72 | 0 | | |
| PHF | .734 | .685 | .000 | .000 | .818 | .000 | .000 | .000 | .000 | .000 | .000 | .884 | .375 | .000 | .858 | .583 | .000 | .750 | .000 | .694 | .863 |

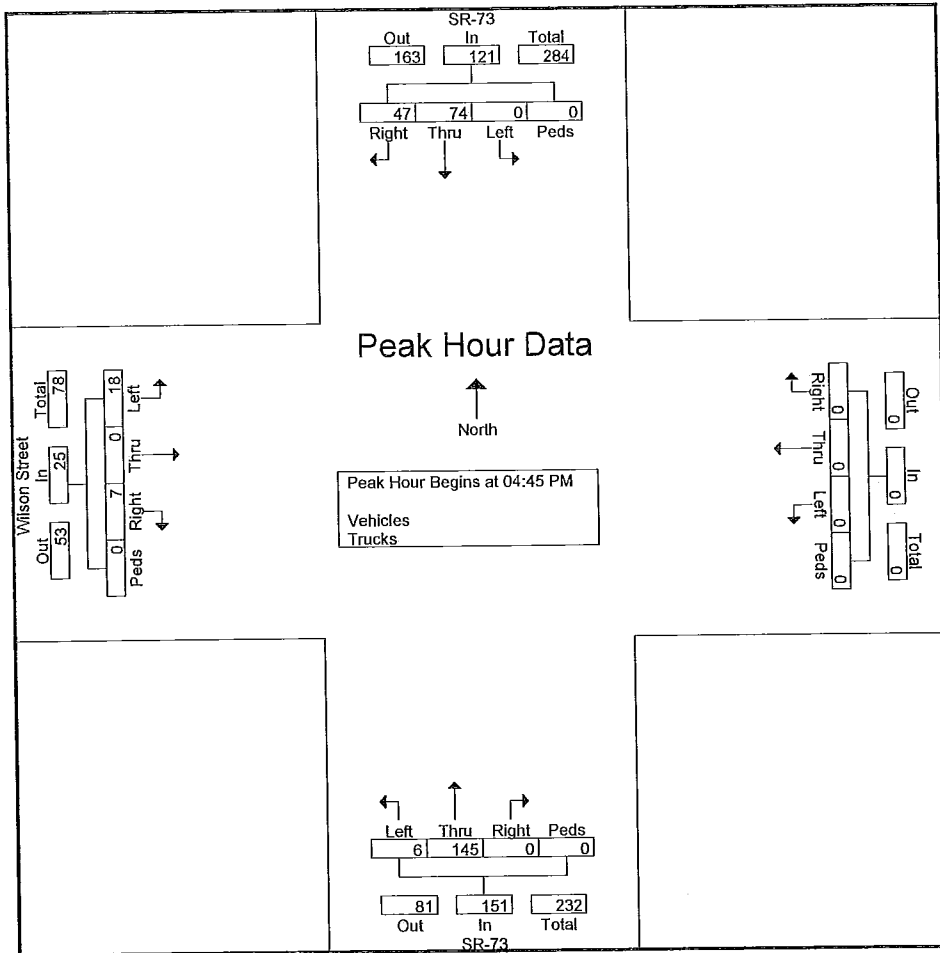

Appendix B Traffix Report Sheets

Traffic Report Sheets

Existing

Level of Service Computation Report

2000 HCM Unsignalized Method (Future Volume Alternative)

Intersection #15 SR-73 & Wilson Street

Average Delay (sec/veh): 2.5 Worst Case Level of Service: A[9.1]

Table with columns for Street Name (SR-73, Wilson Street), Approach (North Bound, South Bound, East Bound, West Bound), Movement (L, T, R), Control, Rights, and Lanes.

Volume Module: Table with columns for Base Vol, Growth Adj, Initial Bse, Added Vol, PasserByVol, Initial Fut, User Adj, PHF Adj, PHF Volume, Reduct Vol, and Final Vol.

Critical Gap Module: Table with columns for Critical Gp and FollowUpTim.

Capacity Module: Table with columns for Cnflct Vol, Potent Cap., Move Cap., and Volume/Cap.

Level of Service Module: Table with columns for 2Way95thQ, Control Del, LOS by Move, Movement, Shared Cap., SharedQueue, Shrd ConDel, Shared LOS, ApproachDel, and ApproachLOS.

Note: Queue reported is the number of cars per lane.

Level of Service Computation Report

2000 HCM Unsignalized Method (Future Volume Alternative)

Intersection #15 SR-73 & Wilson Street

Average Delay (sec/veh): 1.0 Worst Case Level of Service: A[9.6]

Table with columns for Street Name (SR-73, Wilson Street), Approach (North Bound, South Bound, East Bound, West Bound), Movement (L-T-R), Control (Uncontrolled, Stop Sign), Rights (Include), and Lanes (1 0 1 0 0).

Volume Module table with columns for Base Vol, Growth Adj, Initial Bse, Added Vol, PasserByVol, Initial Fut, User Adj, PHF Adj, PHF Volume, Reduct Vol, and Final Vol. across various movement categories.

Critical Gap Module table with columns for Critical Gp and FollowUpTim, showing values like 4.1, 6.4, 6.2, 3.5, 3.3.

Capacity Module table with columns for Cnflct Vol, Potent Cap., Move Cap., and Volume/Cap. across different movement types.

Level of Service Module table with columns for 2Way95thQ, Control Del, LOS by Move, Movement, Shared Cap., SharedQueue, Shrd ConDel, Shared LOS, ApproachDel, and ApproachLOS.

Note: Queue reported is the number of cars per lane.

Traffic Report Sheets

Background

Level Of Service Computation Report

2000 HCM Unsignalized Method (Future Volume Alternative)

Intersection #15 SR-73 & Wilson Street

Average Delay (sec/veh): 2.7 Worst Case Level Of Service: B[10.2]

Street Name: SR-73 Wilson Street

Approach: North Bound South Bound East Bound West Bound

Movement: L - T - R L - T - R L - T - R L - T - R

Control: Uncontrolled Uncontrolled Stop Sign Stop Sign

Rights: Include Include Include Include

Lanes: 1 0 1 0 0 0 0 1 0 1 0 0 1 0 0 0 0 0 0 0

Volume Module: Base Vol: 1 49 0 0 43 2 33 0 1 0 0 0 Growth Adj: 2.33 2.33 2.33 2.33 2.33 2.33 2.33 2.33 2.33 2.33 2.33 2.33 Initial Bse: 2 114 0 0 100 5 77 0 2 0 0 0 Added Vol: 0 0 0 0 0 0 0 0 0 0 0 0 PasserByVol: 0 0 0 0 0 0 0 0 0 0 0 0 Initial Fut: 2 114 0 0 100 5 77 0 2 0 0 0 User Adj: 1.00 1.00 1.00 1.00 1.00 1.00 1.00 1.00 1.00 1.00 1.00 1.00 PHF Adj: 1.00 1.00 1.00 1.00 1.00 1.00 1.00 1.00 1.00 1.00 1.00 1.00 PHF Volume: 2 114 0 0 100 5 77 0 2 0 0 0 Reduct Vol: 0 0 0 0 0 0 0 0 0 0 0 0 Final Vol.: 2 114 0 0 100 5 77 0 2 0 0 0

Critical Gap Module: Critical Gp: 4.1 xxxx xxxxx xxxxx xxxx xxxxx 6.4 xxxx 6.2 xxxxx xxxx xxxxx FollowUpTim: 2.2 xxxx xxxxx xxxxx xxxx xxxxx 3.5 xxxx 3.3 xxxxx xxxx xxxxx

Capacity Module: Cnflct Vol: 105 xxxx xxxxx xxxx xxxx xxxxx 219 xxxx 100 xxxx xxxx xxxxx Potent Cap.: 1499 xxxx xxxxx xxxx xxxx xxxxx 774 xxxx 961 xxxx xxxx xxxxx Move Cap.: 1499 xxxx xxxxx xxxx xxxx xxxxx 773 xxxx 961 xxxx xxxx xxxxx Volume/Cap: 0.00 xxxx xxxx xxxx xxxx xxxxx 0.10 xxxx 0.00 xxxx xxxx xxxxx

Level Of Service Module: 2Way95thQ: 0.0 xxxx xxxxx xxxx xxxx xxxxx xxxx xxxx xxxxx xxxx xxxx xxxxx Control Del: 7.4 xxxx xxxxx xxxxx xxxx xxxxx xxxxx xxxx xxxxx xxxxx xxxx xxxxx LOS by Move: A * * * * * * * * * * * * Movement: LT - LTR - RT LT - LTR - RT LT - LTR - RT LT - LTR - RT Shared Cap.: xxxx xxxx xxxxx xxxx xxxx xxxxx xxxx 777 xxxxx xxxx xxxx xxxxx SharedQueue:xxxxx xxxx xxxxx xxxxx xxxx xxxxx xxxxx 0.3 xxxxx xxxxx xxxx xxxxx Shrd ConDel:xxxxx xxxx xxxxx xxxxx xxxx xxxxx xxxxx 10.2 xxxxx xxxxx xxxx xxxxx Shared LOS: * * * * * * * * * * * * ApproachDel: xxxxxx xxxxxx 10.2 xxxxxx ApproachLOS: * * * * * * * * * * * *

Note: Queue reported is the number of cars per lane.

Level Of Service Computation Report

2000 HCM Unsignalized Method (Future Volume Alternative)

Intersection #15 SR-73 & Wilson Street

Average Delay (sec/veh): 1.2 Worst Case Level Of Service: B[12.0]

| Street Name: | SR-73 | | | | Wilson Street | | | | |
|--------------|--------------|---|--------------|---|---------------|---|------------|---|---|
| Approach: | North Bound | | South Bound | | East Bound | | West Bound | | |
| Movement: | L | T | R | L | T | R | L | T | R |
| Control: | Uncontrolled | | Uncontrolled | | Stop Sign | | Stop Sign | | |
| Rights: | Include | | Include | | Include | | Include | | |
| Lanes: | 1 | 0 | 1 | 0 | 0 | 0 | 1 | 0 | 0 |

| Volume Module: | SR-73 | | SR-73 | | Wilson Street | | Wilson Street | | Wilson Street | | Wilson Street | |
|----------------|-------|------|-------|------|---------------|------|---------------|------|---------------|------|---------------|------|
| Base Vol: | 6 | 145 | 0 | 0 | 74 | 47 | 18 | 0 | 7 | 0 | 0 | 0 |
| Growth Adj: | 2.33 | 2.33 | 2.33 | 2.33 | 2.33 | 2.33 | 2.33 | 2.33 | 2.33 | 2.33 | 2.33 | 2.33 |
| Initial Bse: | 14 | 338 | 0 | 0 | 172 | 109 | 42 | 0 | 16 | 0 | 0 | 0 |
| Added Vol: | 0 | 0 | 0 | 0 | 0 | 0 | 0 | 0 | 0 | 0 | 0 | 0 |
| PasserByVol: | 0 | 0 | 0 | 0 | 0 | 0 | 0 | 0 | 0 | 0 | 0 | 0 |
| Initial Fut: | 14 | 338 | 0 | 0 | 172 | 109 | 42 | 0 | 16 | 0 | 0 | 0 |
| User Adj: | 1.00 | 1.00 | 1.00 | 1.00 | 1.00 | 1.00 | 1.00 | 1.00 | 1.00 | 1.00 | 1.00 | 1.00 |
| PHF Adj: | 1.00 | 1.00 | 1.00 | 1.00 | 1.00 | 1.00 | 1.00 | 1.00 | 1.00 | 1.00 | 1.00 | 1.00 |
| PHF Volume: | 14 | 338 | 0 | 0 | 172 | 109 | 42 | 0 | 16 | 0 | 0 | 0 |
| Reduct Vol: | 0 | 0 | 0 | 0 | 0 | 0 | 0 | 0 | 0 | 0 | 0 | 0 |
| Final Vol.: | 14 | 338 | 0 | 0 | 172 | 109 | 42 | 0 | 16 | 0 | 0 | 0 |

| Critical Gap Module: | SR-73 | | SR-73 | | Wilson Street | | Wilson Street | | Wilson Street | | Wilson Street | |
|----------------------|-------|------|-------|-------|---------------|-------|---------------|------|---------------|-------|---------------|-------|
| Critical Gp: | 4.1 | xxxx | xxxxx | xxxxx | xxxx | xxxxx | 6.4 | xxxx | 6.2 | xxxxx | xxxx | xxxxx |
| FollowUpTim: | 2.2 | xxxx | xxxxx | xxxxx | xxxx | xxxxx | 3.5 | xxxx | 3.3 | xxxxx | xxxx | xxxxx |

| Capacity Module: | SR-73 | | SR-73 | | Wilson Street | | Wilson Street | | Wilson Street | | Wilson Street | |
|------------------|-------|------|-------|------|---------------|-------|---------------|------|---------------|------|---------------|-------|
| Cnflct Vol: | 282 | xxxx | xxxxx | xxxx | xxxx | xxxxx | 538 | xxxx | 172 | xxxx | xxxx | xxxxx |
| Potent Cap.: | 1292 | xxxx | xxxxx | xxxx | xxxx | xxxxx | 507 | xxxx | 876 | xxxx | xxxx | xxxxx |
| Move Cap.: | 1292 | xxxx | xxxxx | xxxx | xxxx | xxxxx | 503 | xxxx | 876 | xxxx | xxxx | xxxxx |
| Volume/Cap: | 0.01 | xxxx | xxxx | xxxx | xxxx | xxxx | 0.08 | xxxx | 0.02 | xxxx | xxxx | xxxx |

| Level Of Service Module: | SR-73 | | SR-73 | | Wilson Street | | Wilson Street | | Wilson Street | | Wilson Street | |
|--------------------------|---------|------|-------|---------|---------------|-------|---------------|------|---------------|---------|---------------|-------|
| 2Way95thQ: | 0.0 | xxxx | xxxxx | xxxx | xxxx | xxxxx | xxxx | xxxx | xxxxx | xxxx | xxxx | xxxxx |
| Control Del: | 7.8 | xxxx | xxxxx | xxxxx | xxxx | xxxxx | xxxxx | xxxx | xxxxx | xxxxx | xxxx | xxxxx |
| LOS by Move: | A | * | * | * | * | * | * | * | * | * | * | * |
| Movement: | LT | LTR | RT | LT | LTR | RT | LT | LTR | RT | LT | LTR | RT |
| Shared Cap.: | xxxx | xxxx | xxxxx | xxxx | xxxx | xxxxx | xxxx | 571 | xxxxx | xxxx | xxxx | xxxxx |
| SharedQueue: | xxxxx | xxxx | xxxxx | xxxxx | xxxx | xxxxx | xxxxx | 0.3 | xxxxx | xxxxx | xxxx | xxxxx |
| Shrd ConDel: | xxxxx | xxxx | xxxxx | xxxxx | xxxx | xxxxx | xxxxx | 12.0 | xxxxx | xxxxx | xxxx | xxxxx |
| Shared LOS: | * | * | * | * | * | * | * | B | * | * | * | * |
| ApproachDel: | xxxxxxx | | | xxxxxxx | | | 12.0 | | | xxxxxxx | | |
| ApproachLOS: | * | | | * | | | B | | | * | | * |

Note: Queue reported is the number of cars per lane.

Traffic Report Sheets

Background + Project

Level Of Service Computation Report
 2000 HCM Operations Method (Future Volume Alternative)

 Intersection #7 SR-73 & 4000 North

Cycle (sec): 60 Critical Vol./Cap.(X): 0.931
 Loss Time (sec): 0 (Y+R=4.0 sec) Average Delay (sec/veh): 24.2
 Optimal Cycle: OPTIMIZED Level Of Service: C

| Street Name: | SR-73 | | | | | | 4000 North | | | | | | | | |
|--------------|-------------|---|---|-------------|---|---|-------------|---|---|-------------|---|---|---|---|---|
| | North Bound | | | South Bound | | | East Bound | | | West Bound | | | | | |
| Approach: | L | T | R | L | T | R | L | T | R | L | T | R | | | |
| Control: | Permitted | | | Protected | | | Prot+Permit | | | Prot+Permit | | | | | |
| Rights: | Include | | | Include | | | Include | | | Include | | | | | |
| Min. Green: | 0 | 0 | 0 | 0 | 0 | 0 | 0 | 0 | 0 | 0 | 0 | 0 | | | |
| Lanes: | 1 | 0 | 2 | 0 | 1 | 2 | 0 | 2 | 0 | 1 | 1 | 0 | 0 | 1 | 0 |

| Volume Module: | North Bound | | | South Bound | | | East Bound | | | West Bound | | |
|----------------|-------------|------|------|-------------|------|------|------------|------|------|------------|------|------|
| Base Vol: | 0 | 49 | 0 | 0 | 43 | 0 | 0 | 0 | 0 | 0 | 0 | 0 |
| Growth Adj: | 2.33 | 2.33 | 2.33 | 2.33 | 2.33 | 2.33 | 2.33 | 2.33 | 2.33 | 2.33 | 2.33 | 2.33 |
| Initial Bse: | 0 | 114 | 0 | 0 | 100 | 0 | 0 | 0 | 0 | 0 | 0 | 0 |
| Added Vol: | 5 | 1300 | 346 | 523 | 940 | 114 | 350 | 522 | 17 | 189 | 170 | 107 |
| PasserByVol: | 0 | 0 | 0 | 0 | 0 | 0 | 0 | 0 | 0 | 0 | 0 | 0 |
| Initial Fut: | 5 | 1414 | 346 | 523 | 1040 | 114 | 350 | 522 | 17 | 189 | 170 | 107 |
| User Adj: | 1.00 | 1.00 | 1.00 | 1.00 | 1.00 | 1.00 | 1.00 | 1.00 | 1.00 | 1.00 | 1.00 | 1.00 |
| PHF Adj: | 1.00 | 1.00 | 1.00 | 1.00 | 1.00 | 1.00 | 1.00 | 1.00 | 1.00 | 1.00 | 1.00 | 1.00 |
| PHF Volume: | 5 | 1414 | 346 | 523 | 1040 | 114 | 350 | 522 | 17 | 189 | 170 | 107 |
| Reduct Vol: | 0 | 0 | 0 | 0 | 0 | 0 | 0 | 0 | 0 | 0 | 0 | 0 |
| Reduced Vol: | 5 | 1414 | 346 | 523 | 1040 | 114 | 350 | 522 | 17 | 189 | 170 | 107 |
| PCE Adj: | 1.00 | 1.00 | 1.00 | 1.00 | 1.00 | 1.00 | 1.00 | 1.00 | 1.00 | 1.00 | 1.00 | 1.00 |
| MLF Adj: | 1.00 | 1.00 | 1.00 | 1.00 | 1.00 | 1.00 | 1.00 | 1.00 | 1.00 | 1.00 | 1.00 | 1.00 |
| Final Vol.: | 5 | 1414 | 346 | 523 | 1040 | 114 | 350 | 522 | 17 | 189 | 170 | 107 |

| Saturation Flow Module: | North Bound | | | South Bound | | | East Bound | | | West Bound | | |
|-------------------------|-------------|------|------|-------------|------|------|------------|------|------|------------|------|------|
| Sat/Lane: | 1900 | 1900 | 1900 | 1900 | 1900 | 1900 | 1900 | 1900 | 1900 | 1900 | 1900 | 1900 |
| Adjustment: | 0.16 | 0.95 | 0.85 | 0.92 | 0.95 | 0.85 | 0.95 | 1.00 | 1.00 | 0.95 | 0.89 | 0.89 |
| Lanes: | 1.00 | 2.00 | 1.00 | 2.00 | 2.00 | 1.00 | 1.00 | 0.97 | 0.03 | 1.00 | 1.84 | 1.16 |
| Final Sat.: | 300 | 3610 | 1615 | 3502 | 3610 | 1615 | 1805 | 1831 | 60 | 1805 | 3131 | 1970 |

| Capacity Analysis Module: | North Bound | | | South Bound | | | East Bound | | | West Bound | | |
|---------------------------|-------------|------|------|-------------|------|------|------------|------|------|------------|------|------|
| Vol/Sat: | 0.02 | 0.39 | 0.21 | 0.15 | 0.29 | 0.07 | 0.19 | 0.29 | 0.29 | 0.10 | 0.05 | 0.05 |
| Crit Moves: | **** | | | **** | | | **** | | | **** | | |
| Green/Cycle: | 0.42 | 0.42 | 0.42 | 0.16 | 0.58 | 0.58 | 0.42 | 0.31 | 0.31 | 0.20 | 0.09 | 0.09 |
| Volume/Cap: | 0.04 | 0.93 | 0.51 | 0.93 | 0.50 | 0.12 | 0.49 | 0.93 | 0.93 | 0.57 | 0.59 | 0.59 |
| Uniform Del: | 10.2 | 16.5 | 12.8 | 24.9 | 7.4 | 5.7 | 12.6 | 20.2 | 20.2 | 21.2 | 26.2 | 26.2 |
| IncramntDel: | 0.1 | 10.6 | 0.6 | 22.4 | 0.2 | 0.1 | 0.5 | 21.9 | 21.9 | 2.4 | 2.0 | 2.0 |
| InitQueueDel: | 0.0 | 0.0 | 0.0 | 0.0 | 0.0 | 0.0 | 0.0 | 0.0 | 0.0 | 0.0 | 0.0 | 0.0 |
| Delay Adj: | 1.00 | 1.00 | 1.00 | 1.00 | 1.00 | 1.00 | 1.00 | 1.00 | 1.00 | 1.00 | 1.00 | 1.00 |
| Delay/Veh: | 10.4 | 27.1 | 13.5 | 47.2 | 7.6 | 5.7 | 13.2 | 42.0 | 42.0 | 23.7 | 28.2 | 28.2 |
| User DelAdj: | 1.00 | 1.00 | 1.00 | 1.00 | 1.00 | 1.00 | 1.00 | 1.00 | 1.00 | 1.00 | 1.00 | 1.00 |
| AdjDel/Veh: | 10.4 | 27.1 | 13.5 | 47.2 | 7.6 | 5.7 | 13.2 | 42.0 | 42.0 | 23.7 | 28.2 | 28.2 |
| LOS by Move: | B | C | B | D | A | A | B | D | D | C | C | C |
| HCM2kAvgQ: | 0 | 19 | 5 | 9 | 6 | 1 | 5 | 15 | 15 | 4 | 3 | 3 |

Level Of Service Computation Report

2000 HCM Operations Method (Future Volume Alternative)

 Intersection #8 SR-73 & Pole Canyon Boulevard

 Cycle (sec): 60 Critical Vol./Cap.(X): 0.775
 Loss Time (sec): 0 (Y+R=4.0 sec) Average Delay (sec/veh): 16.9
 Optimal Cycle: OPTIMIZED Level Of Service: B

| Street Name: | SR-73 | | | | | | Pole Canyon Boulevard | | | | | |
|--------------|-------------|---|---|-------------|---|---|-----------------------|---|---|------------|---|---|
| | North Bound | | | South Bound | | | East Bound | | | West Bound | | |
| Approach: | L | T | R | L | T | R | L | T | R | L | T | R |
| Movement: | | | | | | | | | | | | |
| Control: | Prot+Permit | | | Protected | | | Permitted | | | Permitted | | |
| Rights: | Include | | | Include | | | Include | | | Include | | |
| Min. Green: | 0 | 0 | 0 | 0 | 0 | 0 | 0 | 0 | 0 | 0 | 0 | 0 |
| Lanes: | 1 | 0 | 2 | 0 | 1 | 1 | 1 | 0 | 1 | 0 | 1 | 1 |

| Volume Module: | North Bound | | | South Bound | | | East Bound | | | West Bound | | |
|----------------|-------------|------|------|-------------|------|------|------------|------|------|------------|------|------|
| Base Vol: | 0 | 50 | 0 | 0 | 44 | 0 | 0 | 0 | 0 | 0 | 0 | 0 |
| Growth Adj: | 2.33 | 2.33 | 2.33 | 2.33 | 2.33 | 2.33 | 2.33 | 2.33 | 2.33 | 2.33 | 2.33 | 2.33 |
| Initial Bse: | 0 | 116 | 0 | 0 | 103 | 0 | 0 | 0 | 0 | 0 | 0 | 0 |
| Added Vol: | 55 | 845 | 152 | 556 | 445 | 145 | 403 | 363 | 129 | 110 | 130 | 403 |
| PasserByVol: | 0 | 0 | 0 | 0 | 0 | 0 | 0 | 0 | 0 | 0 | 0 | 0 |
| Initial Fut: | 55 | 961 | 152 | 556 | 548 | 145 | 403 | 363 | 129 | 110 | 130 | 403 |
| User Adj: | 1.00 | 1.00 | 1.00 | 1.00 | 1.00 | 1.00 | 1.00 | 1.00 | 1.00 | 1.00 | 1.00 | 1.00 |
| PHF Adj: | 1.00 | 1.00 | 1.00 | 1.00 | 1.00 | 1.00 | 1.00 | 1.00 | 1.00 | 1.00 | 1.00 | 1.00 |
| PHF Volume: | 55 | 961 | 152 | 556 | 548 | 145 | 403 | 363 | 129 | 110 | 130 | 403 |
| Reduct Vol: | 0 | 0 | 0 | 0 | 0 | 0 | 0 | 0 | 0 | 0 | 0 | 0 |
| Reduced Vol: | 55 | 961 | 152 | 556 | 548 | 145 | 403 | 363 | 129 | 110 | 130 | 403 |
| PCE Adj: | 1.00 | 1.00 | 1.00 | 1.00 | 1.00 | 1.00 | 1.00 | 1.00 | 1.00 | 1.00 | 1.00 | 1.00 |
| MLF Adj: | 1.00 | 1.00 | 1.00 | 1.00 | 1.00 | 1.00 | 1.00 | 1.00 | 1.00 | 1.00 | 1.00 | 1.00 |
| Final Vol.: | 55 | 961 | 152 | 556 | 548 | 145 | 403 | 363 | 129 | 110 | 130 | 403 |

| Saturation Flow Module: | North Bound | | | South Bound | | | East Bound | | | West Bound | | |
|-------------------------|-------------|------|------|-------------|------|------|------------|------|------|------------|------|------|
| Sat/Lane: | 1900 | 1900 | 1900 | 1900 | 1900 | 1900 | 1900 | 1900 | 1900 | 1900 | 1900 | 1900 |
| Adjustment: | 0.95 | 0.95 | 0.85 | 0.92 | 0.95 | 0.85 | 0.61 | 1.00 | 0.85 | 0.38 | 1.00 | 0.85 |
| Lanes: | 1.00 | 2.00 | 1.00 | 2.00 | 2.00 | 1.00 | 1.00 | 1.00 | 1.00 | 1.00 | 1.00 | 1.00 |
| Final Sat.: | 1805 | 3610 | 1615 | 3502 | 3610 | 1615 | 1151 | 1900 | 1615 | 714 | 1900 | 1615 |

| Capacity Analysis Module: | North Bound | | | South Bound | | | East Bound | | | West Bound | | |
|---------------------------|-------------|------|------|-------------|------|------|------------|------|------|------------|------|------|
| Vol/Sat: | 0.03 | 0.27 | 0.09 | 0.16 | 0.15 | 0.09 | 0.35 | 0.19 | 0.08 | 0.15 | 0.07 | 0.25 |
| Crit Moves: | **** | | | **** | | | **** | | | **** | | |
| Green/Cycle: | 0.55 | 0.34 | 0.34 | 0.20 | 0.46 | 0.46 | 0.45 | 0.45 | 0.45 | 0.45 | 0.45 | 0.45 |
| Volume/Cap: | 0.13 | 0.78 | 0.27 | 0.78 | 0.33 | 0.20 | 0.78 | 0.42 | 0.18 | 0.34 | 0.15 | 0.55 |
| Uniform Del: | 7.0 | 17.6 | 14.3 | 22.5 | 10.4 | 9.7 | 13.9 | 11.2 | 9.8 | 10.7 | 9.7 | 12.0 |
| IncramntDel: | 0.1 | 3.1 | 0.3 | 5.3 | 0.1 | 0.1 | 7.2 | 0.3 | 0.1 | 0.6 | 0.1 | 0.9 |
| InitQueueDel: | 0.0 | 0.0 | 0.0 | 0.0 | 0.0 | 0.0 | 0.0 | 0.0 | 0.0 | 0.0 | 0.0 | 0.0 |
| Delay Adj: | 1.00 | 1.00 | 1.00 | 1.00 | 1.00 | 1.00 | 1.00 | 1.00 | 1.00 | 1.00 | 1.00 | 1.00 |
| Delay/Veh: | 7.2 | 20.7 | 14.5 | 27.9 | 10.6 | 9.9 | 21.1 | 11.5 | 9.9 | 11.3 | 9.8 | 12.9 |
| User DelAdj: | 1.00 | 1.00 | 1.00 | 1.00 | 1.00 | 1.00 | 1.00 | 1.00 | 1.00 | 1.00 | 1.00 | 1.00 |
| AdjDel/Veh: | 7.2 | 20.7 | 14.5 | 27.9 | 10.6 | 9.9 | 21.1 | 11.5 | 9.9 | 11.3 | 9.8 | 12.9 |
| LOS by Move: | A | C | B | C | B | A | C | B | A | B | A | B |
| HCM2kAvgQ: | 1 | 11 | 2 | 7 | 4 | 2 | 9 | 5 | 1 | 2 | 1 | 6 |

```

-----
                          Level Of Service Computation Report
                    2000 HCM Unsignalized Method (Future Volume Alternative)
*****
Intersection #84 SR-73 & Commercial Access #1
*****
Average Delay (sec/veh):      0.3      Worst Case Level Of Service: C[ 20.7]
*****
Approach:      North Bound      South Bound      East Bound      West Bound
Movement:      L - T - R      L - T - R      L - T - R      L - T - R
-----|-----|-----|-----|
Control:      Uncontrolled      Uncontrolled      Stop Sign      Stop Sign
Rights:      Include      Include      Include      Include
Lanes:      0 0 1 0 1      1 0 1 0 0      0 0 0 0 0      1 0 0 0 1
-----|-----|-----|-----|
Volume Module:
Base Vol:      0 49 0      0 43 0      0 0 0      0 0 0
Growth Adj:  2.33 2.33 2.33  2.33 2.33 2.33  2.33 2.33 2.33  2.33 2.33 2.33
Initial Bse:  0 114 0      0 100 0      0 0 0      0 0 0
Added Vol:    0 1038 1      23 661 0      0 0 0      0 0 14
PasserByVol:  0 0 0      0 0 0      0 0 0      0 0 0
Initial Fut:  0 1152 1      23 761 0      0 0 0      0 0 14
User Adj:    1.00 1.00 1.00  1.00 1.00 1.00  1.00 1.00 1.00  1.00 1.00 1.00
PHF Adj:     1.00 1.00 1.00  1.00 1.00 1.00  1.00 1.00 1.00  1.00 1.00 1.00
PHF Volume:   0 1152 1      23 761 0      0 0 0      0 0 14
Reduct Vol:   0 0 0      0 0 0      0 0 0      0 0 0
Final Vol.:  0 1152 1      23 761 0      0 0 0      0 0 14
Critical Gap Module:
Critical Gap:xxxxx xxxx xxxxx  4.1 xxxx xxxxx xxxxx xxxx xxxxx xxxxx xxxx  6.2
FollowUpTim:xxxxx xxxx xxxxx  2.2 xxxx xxxxx xxxxx xxxx xxxxx xxxxx xxxx  3.3
-----|-----|-----|-----|
Capacity Module:
Cnflct Vol:  xxxx xxxx xxxxx  1153 xxxx xxxxx xxxx xxxx xxxxx xxxx xxxx  1152
Potent Cap.: xxxx xxxx xxxxx  613 xxxx xxxxx xxxx xxxx xxxxx xxxx xxxx  243
Move Cap.:   xxxx xxxx xxxxx  613 xxxx xxxxx xxxx xxxx xxxxx xxxx xxxx  243
Volume/Cap:  xxxx xxxx xxxx  0.04 xxxx xxxx xxxx xxxx xxxxx xxxx xxxx  0.06
-----|-----|-----|-----|
Level Of Service Module:
2Way95thQ:   xxxx xxxx xxxxx  0.1 xxxx xxxxx xxxx xxxx xxxxx xxxx xxxx  0.2
Control Del:xxxxx xxxx xxxxx  11.1 xxxx xxxxx xxxxx xxxx xxxxx xxxxx xxxx  20.7
LOS by Move: * * *      B * *      * * *      * * *      C
Movement:    LT - LTR - RT  LT - LTR - RT  LT - LTR - RT  LT - LTR - RT
Shared Cap.: xxxx xxxx xxxxx  xxxx xxxx xxxxx xxxx xxxx xxxxx xxxx xxxx xxxxx
SharedQueue:xxxxx xxxx xxxxx  xxxxx xxxx xxxxx xxxxx xxxx xxxxx xxxxx xxxx xxxxx
Shrd ConDel:xxxxx xxxx xxxxx  xxxxx xxxx xxxxx xxxxx xxxx xxxxx xxxxx xxxx xxxxx
Shared LOS:  * * *      * * *      * * *      * * *      *
ApproachDel: xxxxxx      xxxxxx      xxxxxx      20.7
ApproachLOS: *      *      *      C
*****

```

Note: Queue reported is the number of cars per lane.

Level Of Service Computation Report

2000 HCM Unsignalized Method (Future Volume Alternative)

 Intersection #85 SR-73 & Commercial Access #2

Average Delay (sec/veh): 0.3 Worst Case Level Of Service: C[22.7]

| Approach: | North Bound | | | South Bound | | | East Bound | | | West Bound | | |
|-----------|--------------|---|---|--------------|---|---|------------|---|---|------------|---|---|
| Movement: | L | T | R | L | T | R | L | T | R | L | T | R |
| Control: | Uncontrolled | | | Uncontrolled | | | Stop Sign | | | Stop Sign | | |
| Rights: | Include | | | Include | | | Include | | | Include | | |
| Lanes: | 0 | 0 | 1 | 0 | 1 | 0 | 0 | 0 | 0 | 1 | 0 | 0 |

Volume Module:

| | | | | | | | | | | | | |
|--------------|------|------|------|------|------|------|------|------|------|------|------|------|
| Base Vol: | 0 | 49 | 0 | 0 | 43 | 0 | 0 | 0 | 0 | 0 | 0 | 0 |
| Growth Adj: | 2.33 | 2.33 | 2.33 | 2.33 | 2.33 | 2.33 | 2.33 | 2.33 | 2.33 | 2.33 | 2.33 | 2.33 |
| Initial Bse: | 0 | 114 | 0 | 0 | 100 | 0 | 0 | 0 | 0 | 0 | 0 | 0 |
| Added Vol: | 0 | 1024 | 1 | 23 | 639 | 0 | 0 | 0 | 0 | 1 | 0 | 15 |
| PasserByVol: | 0 | 0 | 0 | 0 | 0 | 0 | 0 | 0 | 0 | 0 | 0 | 0 |
| Initial Fut: | 0 | 1138 | 1 | 23 | 739 | 0 | 0 | 0 | 0 | 1 | 0 | 15 |
| User Adj: | 1.00 | 1.00 | 1.00 | 1.00 | 1.00 | 1.00 | 1.00 | 1.00 | 1.00 | 1.00 | 1.00 | 1.00 |
| PHF Adj: | 1.00 | 1.00 | 1.00 | 1.00 | 1.00 | 1.00 | 1.00 | 1.00 | 1.00 | 1.00 | 1.00 | 1.00 |
| PHF Volume: | 0 | 1138 | 1 | 23 | 739 | 0 | 0 | 0 | 0 | 1 | 0 | 15 |
| Reduct Vol: | 0 | 0 | 0 | 0 | 0 | 0 | 0 | 0 | 0 | 0 | 0 | 0 |
| Final Vol.: | 0 | 1138 | 1 | 23 | 739 | 0 | 0 | 0 | 0 | 1 | 0 | 15 |

Critical Gap Module:

| | | | | | | | | | | | | |
|--------------|-------|------|-------|-----|------|-------|-------|------|-------|-----|------|-----|
| Critical Gp: | xxxxx | xxxx | xxxxx | 4.1 | xxxx | xxxxx | xxxxx | xxxx | xxxxx | 6.4 | xxxx | 6.2 |
| FollowUpTim: | xxxxx | xxxx | xxxxx | 2.2 | xxxx | xxxxx | xxxxx | xxxx | xxxxx | 3.5 | xxxx | 3.3 |

Capacity Module:

| | | | | | | | | | | | | |
|--------------|------|------|-------|------|------|-------|------|------|-------|------|------|------|
| Cnflct Vol: | xxxx | xxxx | xxxxx | 1139 | xxxx | xxxxx | xxxx | xxxx | xxxxx | 1923 | xxxx | 1138 |
| Potent Cap.: | xxxx | xxxx | xxxxx | 621 | xxxx | xxxxx | xxxx | xxxx | xxxxx | 74 | xxxx | 247 |
| Move Cap.: | xxxx | xxxx | xxxxx | 621 | xxxx | xxxxx | xxxx | xxxx | xxxxx | 72 | xxxx | 247 |
| Volume/Cap: | xxxx | xxxx | xxxx | 0.04 | xxxx | xxxx | xxxx | xxxx | xxxx | 0.01 | xxxx | 0.06 |

Level Of Service Module:

| | | | | | | | | | | | | |
|--------------|---------|------|-------|---------|------|-------|---------|------|-------|-------|------|-------|
| 2Way95thQ: | xxxx | xxxx | xxxxx | 0.1 | xxxx | xxxxx | xxxx | xxxx | xxxxx | 0.0 | xxxx | 0.2 |
| Control Del: | xxxxx | xxxx | xxxxx | 11.0 | xxxx | xxxxx | xxxxx | xxxx | xxxxx | 55.5 | xxxx | 20.5 |
| LOS by Move: | * | * | * | B | * | * | * | * | * | F | * | C |
| Movement: | LT | LTR | RT | LT | LTR | RT | LT | LTR | RT | LT | LTR | RT |
| Shared Cap.: | xxxx | xxxx | xxxxx | xxxx | xxxx | xxxxx | xxxx | xxxx | xxxxx | xxxx | xxxx | xxxxx |
| SharedQueue: | xxxxx | xxxx | xxxxx | xxxxx | xxxx | xxxxx | xxxxx | xxxx | xxxxx | xxxxx | xxxx | xxxxx |
| Shrd ConDel: | xxxxx | xxxx | xxxxx | xxxxx | xxxx | xxxxx | xxxxx | xxxx | xxxxx | xxxxx | xxxx | xxxxx |
| Shared LOS: | * | * | * | * | * | * | * | * | * | * | * | * |
| ApproachDel: | xxxxxxx | | | xxxxxxx | | | xxxxxxx | | | 22.7 | | |
| ApproachLOS: | * | | | * | | | * | | | C | | |

Note: Queue reported is the number of cars per lane.

Level Of Service Computation Report

2000 HCM Unsignalized Method (Future Volume Alternative)

 Intersection #35 SR-73 & Residential Access

Average Delay (sec/veh): 1.5 Worst Case Level Of Service: D[26.5]

| Approach: | North Bound | | | South Bound | | | East Bound | | | West Bound | | | | | | | | |
|-----------|--------------|---|---|--------------|---|---|------------|---|---|------------|---|---|---|---|---|---|---|---|
| Movement: | L | T | R | L | T | R | L | T | R | L | T | R | | | | | | |
| Control: | Uncontrolled | | | Uncontrolled | | | Stop Sign | | | Stop Sign | | | | | | | | |
| Rights: | Include | | | Include | | | Include | | | Include | | | | | | | | |
| Lanes: | 0 | 0 | 1 | 0 | 1 | 0 | 1 | 0 | 1 | 0 | 0 | 0 | 0 | 0 | 0 | 0 | 0 | 1 |

Volume Module:

| | | | | | | | | | | | | |
|--------------|------|------|------|------|------|------|------|------|------|------|------|------|
| Base Vol: | 0 | 49 | 0 | 0 | 43 | 0 | 0 | 0 | 0 | 0 | 0 | 0 |
| Growth Adj: | 2.33 | 2.33 | 2.33 | 2.33 | 2.33 | 2.33 | 2.33 | 2.33 | 2.33 | 2.33 | 2.33 | 2.33 |
| Initial Bse: | 0 | 114 | 0 | 0 | 100 | 0 | 0 | 0 | 0 | 0 | 0 | 0 |
| Added Vol: | 0 | 943 | 3 | 32 | 607 | 0 | 0 | 0 | 0 | 9 | 0 | 82 |
| PasserByVol: | 0 | 0 | 0 | 0 | 0 | 0 | 0 | 0 | 0 | 0 | 0 | 0 |
| Initial Fut: | 0 | 1057 | 3 | 32 | 707 | 0 | 0 | 0 | 0 | 9 | 0 | 82 |
| User Adj: | 1.00 | 1.00 | 1.00 | 1.00 | 1.00 | 1.00 | 1.00 | 1.00 | 1.00 | 1.00 | 1.00 | 1.00 |
| PHF Adj: | 1.00 | 1.00 | 1.00 | 1.00 | 1.00 | 1.00 | 1.00 | 1.00 | 1.00 | 1.00 | 1.00 | 1.00 |
| PHF Volume: | 0 | 1057 | 3 | 32 | 707 | 0 | 0 | 0 | 0 | 9 | 0 | 82 |
| Reduct Vol: | 0 | 0 | 0 | 0 | 0 | 0 | 0 | 0 | 0 | 0 | 0 | 0 |
| Final Vol.: | 0 | 1057 | 3 | 32 | 707 | 0 | 0 | 0 | 0 | 9 | 0 | 82 |

Critical Gap Module:

| | | | | | | | | | |
|-------------------------------|-----|------|--------|-------|------|--------|-----|------|-----|
| Critical Gap:xxxxx xxxx xxxxx | 4.1 | xxxx | xxxxxx | xxxxx | xxxx | xxxxxx | 6.4 | xxxx | 6.2 |
| FollowUpTim:xxxxx xxxx xxxxx | 2.2 | xxxx | xxxxxx | xxxxx | xxxx | xxxxxx | 3.5 | xxxx | 3.3 |

Capacity Module:

| | | | | | | | | | |
|------------------------------|------|------|--------|------|------|--------|------|------|------|
| Cnflct Vol: xxxx xxxx xxxxx | 1060 | xxxx | xxxxxx | xxxx | xxxx | xxxxxx | 1828 | xxxx | 1057 |
| Potent Cap.: xxxx xxxx xxxxx | 665 | xxxx | xxxxxx | xxxx | xxxx | xxxxxx | 85 | xxxx | 276 |
| Move Cap.: xxxx xxxx xxxxx | 665 | xxxx | xxxxxx | xxxx | xxxx | xxxxxx | 82 | xxxx | 276 |
| Volume/Cap: xxxx xxxx xxxxx | 0.05 | xxxx | xxxxxx | xxxx | xxxx | xxxxxx | 0.11 | xxxx | 0.30 |

Level Of Service Module:

| | | | | | | | | | |
|-------------------------------|---------------|---------------|---------------|---------------|---------------|---------------|---------------|---------------|--------|
| 2Way95thQ: xxxx xxxx xxxxx | 0.2 | xxxx | xxxxxx | xxxx | xxxx | xxxxxx | 0.4 | xxxx | 1.2 |
| Control Del:xxxxx xxxx xxxxx | 10.7 | xxxx | xxxxxx | xxxxxx | xxxx | xxxxxx | 54.1 | xxxx | 23.5 |
| LOS by Move: * * * | B | * | * | * | * | * | F | * | C |
| Movement: LT - LTR - RT | LT - LTR - RT | LT - LTR - RT | LT - LTR - RT | LT - LTR - RT | LT - LTR - RT | LT - LTR - RT | LT - LTR - RT | LT - LTR - RT | |
| Shared Cap.: xxxx xxxx xxxxx | xxxx | xxxx | xxxxxx | xxxx | xxxx | xxxxxx | xxxx | xxxx | xxxxxx |
| Shared Queue:xxxxx xxxx xxxxx | xxxxxx | xxxx | xxxxxx | xxxxxx | xxxx | xxxxxx | xxxxxx | xxxx | xxxxxx |
| Shrd ConDel:xxxxx xxxx xxxxx | xxxxxx | xxxx | xxxxxx | xxxxxx | xxxx | xxxxxx | xxxxxx | xxxx | xxxxxx |
| Shared LOS: * * * | * | * | * | * | * | * | * | * | * |
| ApproachDel: xxxxxx | xxxxxx | xxxxxx | xxxxxx | xxxxxx | xxxxxx | xxxxxx | 26.5 | | |
| ApproachLOS: * | * | * | * | * | * | * | D | | |

Note: Queue reported is the number of cars per lane.

Level Of Service Computation Report
 2000 HCM Operations Method (Future Volume Alternative)

 Intersection #9 SR-73 & Ranch Lane

Cycle (sec): 60 Critical Vol./Cap.(X): 0.754
 Loss Time (sec): 0 (Y+R=4.0 sec) Average Delay (sec/veh): 15.7
 Optimal Cycle: OPTIMIZED Level Of Service: B

| Street Name: | SR-73 | | | | | | Ranch Lane | | | | | | |
|--------------|-------------|---|---|-------------|---|---|-------------|---|---|-------------|---|---|---|
| | North Bound | | | South Bound | | | East Bound | | | West Bound | | | |
| Approach: | L | T | R | L | T | R | L | T | R | L | T | R | |
| Control: | Permitted | | | Permitted | | | Prot+Permit | | | Prot+Permit | | | |
| Rights: | Include | | | Include | | | Include | | | Include | | | |
| Min. Green: | 0 | 0 | 0 | 0 | 0 | 0 | 0 | 0 | 0 | 0 | 0 | 0 | |
| Lanes: | 1 | 0 | 1 | 0 | 1 | 0 | 1 | 1 | 0 | 0 | 1 | 0 | 1 |

| Volume Module: | SR-73 North | | | SR-73 South | | | Ranch Lane East | | | Ranch Lane West | | |
|----------------|-------------|------|------|-------------|------|------|-----------------|------|------|-----------------|------|------|
| Base Vol: | 0 | 49 | 0 | 0 | 43 | 0 | 0 | 0 | 0 | 0 | 0 | 0 |
| Growth Adj: | 2.33 | 2.33 | 2.33 | 2.33 | 2.33 | 2.33 | 2.33 | 2.33 | 2.33 | 2.33 | 2.33 | 2.33 |
| Initial Bse: | 0 | 114 | 0 | 0 | 100 | 0 | 0 | 0 | 0 | 0 | 0 | 0 |
| Added Vol: | 68 | 168 | 425 | 237 | 172 | 207 | 420 | 275 | 178 | 270 | 110 | 359 |
| PasserByVol: | 0 | 0 | 0 | 0 | 0 | 0 | 0 | 0 | 0 | 0 | 0 | 0 |
| Initial Fut: | 68 | 282 | 425 | 237 | 272 | 207 | 420 | 275 | 178 | 270 | 110 | 359 |
| User Adj: | 1.00 | 1.00 | 1.00 | 1.00 | 1.00 | 1.00 | 1.00 | 1.00 | 1.00 | 1.00 | 1.00 | 1.00 |
| PHF Adj: | 1.00 | 1.00 | 1.00 | 1.00 | 1.00 | 1.00 | 1.00 | 1.00 | 1.00 | 1.00 | 1.00 | 1.00 |
| PHF Volume: | 68 | 282 | 425 | 237 | 272 | 207 | 420 | 275 | 178 | 270 | 110 | 359 |
| Reduct Vol: | 0 | 0 | 0 | 0 | 0 | 0 | 0 | 0 | 0 | 0 | 0 | 0 |
| Reduced Vol: | 68 | 282 | 425 | 237 | 272 | 207 | 420 | 275 | 178 | 270 | 110 | 359 |
| PCE Adj: | 1.00 | 1.00 | 1.00 | 1.00 | 1.00 | 1.00 | 1.00 | 1.00 | 1.00 | 1.00 | 1.00 | 1.00 |
| MLF Adj: | 1.00 | 1.00 | 1.00 | 1.00 | 1.00 | 1.00 | 1.00 | 1.00 | 1.00 | 1.00 | 1.00 | 1.00 |
| Final Vol.: | 68 | 282 | 425 | 237 | 272 | 207 | 420 | 275 | 178 | 270 | 110 | 359 |

| Saturation Flow Module: | SR-73 North | | | SR-73 South | | | Ranch Lane East | | | Ranch Lane West | | |
|-------------------------|-------------|------|------|-------------|------|------|-----------------|------|------|-----------------|------|------|
| Sat/Lane: | 1900 | 1900 | 1900 | 1900 | 1900 | 1900 | 1900 | 1900 | 1900 | 1900 | 1900 | 1900 |
| Adjustment: | 0.43 | 1.00 | 0.85 | 0.42 | 1.00 | 0.85 | 0.95 | 0.94 | 0.94 | 0.95 | 1.00 | 0.85 |
| Lanes: | 1.00 | 1.00 | 1.00 | 1.00 | 1.00 | 1.00 | 1.00 | 0.61 | 0.39 | 1.00 | 1.00 | 1.00 |
| Final Sat.: | 811 | 1900 | 1615 | 792 | 1900 | 1615 | 1805 | 1085 | 703 | 1805 | 1900 | 1615 |

| Capacity Analysis Module: | SR-73 North | | | SR-73 South | | | Ranch Lane East | | | Ranch Lane West | | |
|---------------------------|-------------|------|------|-------------|------|------|-----------------|------|------|-----------------|------|------|
| Vol/Sat: | 0.08 | 0.15 | 0.26 | 0.30 | 0.14 | 0.13 | 0.23 | 0.25 | 0.25 | 0.15 | 0.06 | 0.22 |
| Crit Moves: | | | | **** | | | | **** | | | | |
| Green/Cycle: | 0.40 | 0.40 | 0.40 | 0.40 | 0.40 | 0.40 | 0.60 | 0.38 | 0.38 | 0.52 | 0.29 | 0.29 |
| Volume/Cap: | 0.21 | 0.37 | 0.66 | 0.75 | 0.36 | 0.32 | 0.48 | 0.67 | 0.67 | 0.48 | 0.20 | 0.75 |
| Uniform Del: | 11.9 | 12.8 | 14.8 | 15.6 | 12.7 | 12.5 | 6.2 | 15.5 | 15.5 | 8.8 | 15.8 | 19.2 |
| IncrementDel: | 0.3 | 0.3 | 2.6 | 9.9 | 0.3 | 0.3 | 0.4 | 2.6 | 2.6 | 0.6 | 0.2 | 6.7 |
| InitQueueDel: | 0.0 | 0.0 | 0.0 | 0.0 | 0.0 | 0.0 | 0.0 | 0.0 | 0.0 | 0.0 | 0.0 | 0.0 |
| Delay Adj: | 1.00 | 1.00 | 1.00 | 1.00 | 1.00 | 1.00 | 1.00 | 1.00 | 1.00 | 1.00 | 1.00 | 1.00 |
| Delay/Veh: | 12.2 | 13.1 | 17.4 | 25.5 | 13.0 | 12.8 | 6.7 | 18.0 | 18.0 | 9.5 | 16.0 | 25.9 |
| User DelAdj: | 1.00 | 1.00 | 1.00 | 1.00 | 1.00 | 1.00 | 1.00 | 1.00 | 1.00 | 1.00 | 1.00 | 1.00 |
| AdjDel/Veh: | 12.2 | 13.1 | 17.4 | 25.5 | 13.0 | 12.8 | 6.7 | 18.0 | 18.0 | 9.5 | 16.0 | 25.9 |
| LOS by Move: | B | B | B | C | B | B | A | B | B | A | B | C |
| HCM2kAvgQ: | 1 | 4 | 8 | 6 | 4 | 3 | 5 | 8 | 8 | 4 | 2 | 8 |

```

-----
Level Of Service Computation Report
FHWA Roundabout Method (Future Volume Alternative)
*****
Intersection #1 Westhoff Way & Pole Canyon Loop South
*****
Average Delay (sec/veh):      4.4      Level Of Service: A
*****
Street Name:      Westhoff Way      Pole Canyon Circle South
Approach:      North Bound      South Bound      East Bound      West Bound
Movement:      L - T - R      L - T - R      L - T - R      L - T - R
-----|-----|-----|-----|
Control:      Yield Sign      Yield Sign      Yield Sign      Yield Sign
Lanes:      1      1      1      1
-----|-----|-----|-----|
Volume Module:
Base Vol:      0      0      0      0      0      0      0      0      0      0      0      0
Growth Adj:  1.00 1.00  1.00  1.00 1.00  1.00  1.00 1.00  1.00  1.00 1.00  1.00
Initial Bse:   0      0      0      0      0      0      0      0      0      0      0      0
Added Vol:    31     82     40    148 252     0      0     19     97     97     6     49
PasserByVol:   0      0      0      0      0      0      0      0      0      0      0      0
Initial Fut:   31     82     40    148 252     0      0     19     97     97     6     49
User Adj:     1.00 1.00  1.00  1.00 1.00  1.00  1.00 1.00  1.00  1.00 1.00  1.00
PHF Adj:      1.00 1.00  1.00  1.00 1.00  1.00  1.00 1.00  1.00  1.00 1.00  1.00
PHF Volume:   31     82     40    148 252     0      0     19     97     97     6     49
Reduct Vol:   0      0      0      0      0      0      0      0      0      0      0      0
Reduced Vol:  31     82     40    148 252     0      0     19     97     97     6     49
PCE Adj:      1.00 1.00  1.00  1.00 1.00  1.00  1.00 1.00  1.00  1.00 1.00  1.00
MLF Adj:      1.00 1.00  1.00  1.00 1.00  1.00  1.00 1.00  1.00  1.00 1.00  1.00
Final Vol.:   31     82     40    148 252     0      0     19     97     97     6     49
-----|-----|-----|-----|
PCE Module:
AutoPCE:      31     82     40    148 252     0      0     19     97     97     6     49
TruckPCE:     0      0      0      0      0      0      0      0      0      0      0      0
ComboPCE:     0      0      0      0      0      0      0      0      0      0      0      0
BicyclePCE:   0      0      0      0      0      0      0      0      0      0      0      0
AdjVolume:    31     82     40    148 252     0      0     19     97     97     6     49
-----|-----|-----|-----|
Delay Module: >> Time Period: 0.25 hours <<
CircVolume:   167      134      497      113
MaxVolume:   1110     1128     932     1139
PedVolume:    0          0          0          0
AdjMaxVol:   1110     1128     932     1139
ApproachVol:  153      400      116      152
ApproachDel:  3.8      4.9      4.4      3.6
Queue:       0.5      1.6      0.4      0.5

```

Level Of Service Computation Report
 FHWA Roundabout Method (Future Volume Alternative)

 Intersection #2 Westhoff Way & Pole Canyon Loop North

Average Delay (sec/veh): 6.6 Level Of Service: A

| Street Name: | Westhoff Way | | | | Pole Canyon Circle North | | | | | | | |
|--------------|--------------|---|-------------|---|--------------------------|---|------------|---|---|---|---|---|
| Approach: | North Bound | | South Bound | | East Bound | | West Bound | | | | | |
| Movement: | L | T | R | L | T | R | L | T | R | L | T | R |
| Control: | Yield Sign | | Yield Sign | | Yield Sign | | Yield Sign | | | | | |
| Lanes: | 1 | | 1 | | 1 | | 1 | | | | | |

Volume Module:

| | | | | | | | | | | | | |
|--------------|------|------|------|------|------|------|------|------|------|------|------|------|
| Base Vol: | 0 | 0 | 0 | 0 | 0 | 0 | 0 | 0 | 0 | 0 | 0 | 0 |
| Growth Adj: | 1.00 | 1.00 | 1.00 | 1.00 | 1.00 | 1.00 | 1.00 | 1.00 | 1.00 | 1.00 | 1.00 | 1.00 |
| Initial Bse: | 0 | 0 | 0 | 0 | 0 | 0 | 0 | 0 | 0 | 0 | 0 | 0 |
| Added Vol: | 5 | 55 | 18 | 528 | 168 | 0 | 0 | 249 | 14 | 6 | 81 | 172 |
| PasserByVol: | 0 | 0 | 0 | 0 | 0 | 0 | 0 | 0 | 0 | 0 | 0 | 0 |
| Initial Fut: | 5 | 55 | 18 | 528 | 168 | 0 | 0 | 249 | 14 | 6 | 81 | 172 |
| User Adj: | 1.00 | 1.00 | 1.00 | 1.00 | 1.00 | 1.00 | 1.00 | 1.00 | 1.00 | 1.00 | 1.00 | 1.00 |
| PHF Adj: | 1.00 | 1.00 | 1.00 | 1.00 | 1.00 | 1.00 | 1.00 | 1.00 | 1.00 | 1.00 | 1.00 | 1.00 |
| PHF Volume: | 5 | 55 | 18 | 528 | 168 | 0 | 0 | 249 | 14 | 6 | 81 | 172 |
| Reduct Vol: | 0 | 0 | 0 | 0 | 0 | 0 | 0 | 0 | 0 | 0 | 0 | 0 |
| Reduced Vol: | 5 | 55 | 18 | 528 | 168 | 0 | 0 | 249 | 14 | 6 | 81 | 172 |
| PCE Adj: | 1.00 | 1.00 | 1.00 | 1.00 | 1.00 | 1.00 | 1.00 | 1.00 | 1.00 | 1.00 | 1.00 | 1.00 |
| MLF Adj: | 1.00 | 1.00 | 1.00 | 1.00 | 1.00 | 1.00 | 1.00 | 1.00 | 1.00 | 1.00 | 1.00 | 1.00 |
| Final Vol.: | 5 | 55 | 18 | 528 | 168 | 0 | 0 | 249 | 14 | 6 | 81 | 172 |

PCE Module:

| | | | | | | | | | | | | |
|-------------|---|----|----|-----|-----|---|---|-----|----|---|----|-----|
| AutoPCE: | 5 | 55 | 18 | 528 | 168 | 0 | 0 | 249 | 14 | 6 | 81 | 172 |
| TruckPCE: | 0 | 0 | 0 | 0 | 0 | 0 | 0 | 0 | 0 | 0 | 0 | 0 |
| ComboPCE: | 0 | 0 | 0 | 0 | 0 | 0 | 0 | 0 | 0 | 0 | 0 | 0 |
| BicyclePCE: | 0 | 0 | 0 | 0 | 0 | 0 | 0 | 0 | 0 | 0 | 0 | 0 |
| AdjVolume: | 5 | 55 | 18 | 528 | 168 | 0 | 0 | 249 | 14 | 6 | 81 | 172 |

Delay Module: >> Time Period: 0.25 hours <<

| | | | | |
|--------------|-----|------|-----|------|
| CircVolume: | 777 | 92 | 702 | 60 |
| MaxVolume: | 780 | 1150 | 821 | 1168 |
| PedVolume: | 0 | 0 | 0 | 0 |
| AdjMaxVol: | 780 | 1150 | 821 | 1168 |
| ApproachVol: | 78 | 696 | 263 | 259 |
| ApproachDel: | 5.1 | 7.8 | 6.4 | 4.0 |
| Queue: | 0.3 | 4.3 | 1.4 | 0.8 |

```

-----
Level Of Service Computation Report
FHWA Roundabout Method (Future Volume Alternative)
*****
Intersection #3 Smith Lane & Pole Canyon Loop
*****
Average Delay (sec/veh):      6.5      Level Of Service: A
*****
Street Name:      Smith Lane      Pole Canyon Loop
Approach:      North Bound      South Bound      East Bound      West Bound
Movement:      L - T - R      L - T - R      L - T - R      L - T - R
-----|-----|-----|-----|
Control:      Yield Sign      Yield Sign      Yield Sign      Yield Sign
Lanes:      1      1      1      1
-----|-----|-----|-----|
Volume Module:
Base Vol:      0      0      0      0      0      0      0      0      0      0      0      0
Growth Adj:  1.00 1.00 1.00 1.00 1.00 1.00 1.00 1.00 1.00 1.00 1.00 1.00
Initial Bse:  0      0      0      0      0      0      0      0      0      0      0      0
Added Vol:    131  76      0      0  173  106  326      0  339      0      0      0
PasserByVol:  0      0      0      0      0      0      0      0      0      0      0      0
Initial Fut:  131  76      0      0  173  106  326      0  339      0      0      0
User Adj:    1.00 1.00 1.00 1.00 1.00 1.00 1.00 1.00 1.00 1.00 1.00 1.00
PHF Adj:    1.00 1.00 1.00 1.00 1.00 1.00 1.00 1.00 1.00 1.00 1.00 1.00
PHF Volume:  131  76      0      0  173  106  326      0  339      0      0      0
Reduct Vol:  0      0      0      0      0      0      0      0      0      0      0      0
Reduced Vol: 131  76      0      0  173  106  326      0  339      0      0      0
PCE Adj:    1.00 1.00 1.00 1.00 1.00 1.00 1.00 1.00 1.00 1.00 1.00 1.00
MLF Adj:    1.00 1.00 1.00 1.00 1.00 1.00 1.00 1.00 1.00 1.00 1.00 1.00
Final Vol.:  131  76      0      0  173  106  326      0  339      0      0      0
-----|-----|-----|-----|
PCE Module:
AutoPCE:    131  76      0      0  173  106  326      0  339      0      0      0
TruckPCE:   0      0      0      0      0      0      0      0      0      0      0      0
ComboPCE:   0      0      0      0      0      0      0      0      0      0      0      0
BicyclePCE: 0      0      0      0      0      0      0      0      0      0      0      0
AdjVolume:  131  76      0      0  173  106  326      0  339      0      0      0
-----|-----|-----|-----|
Delay Module: >> Time Period: 0.25 hours <<
CircVolume:      326      131      173      533
MaxVolume:      1024      1129      1107      xxxxxx
PedVolume:        0          0          0          0
AdjMaxVol:      1024      1129      1107      xxxxxx
ApproachVol:     207      279      665      xxxxxx
ApproachDel:     4.4      4.2      8.0      xxxxxx
Queue:           0.8      1.0      4.2      xxxx

```

```

-----
Level Of Service Computation Report
FHWA Roundabout Method (Future Volume Alternative)
*****
Intersection #4 Pole Canyon Boulevard & Pole Canyon Loop
*****
Average Delay (sec/veh):      4.6      Level Of Service: A
*****
Street Name:      Pole Canyon Boulevard      Pole Canyon Loop
Approach:      North Bound      South Bound      East Bound      West Bound
Movement:      L - T - R      L - T - R      L - T - R      L - T - R
-----|-----|-----|-----|
Control:      Yield Sign      Yield Sign      Yield Sign      Yield Sign
Lanes:      1      1      1      1
-----|-----|-----|-----|
Volume Module:
Base Vol:      0      0      0      0      0      0      0      0      0      0      0      0
Growth Adj:  1.00 1.00 1.00 1.00 1.00 1.00 1.00 1.00 1.00 1.00 1.00 1.00
Initial Bse:   0      0      0      0      0      0      0      0      0      0      0      0
Added Vol:    12 377      0      0 123      84 260      0 38      0      0      0
PasserByVol:   0      0      0      0      0      0      0      0      0      0      0      0
Initial Fut:  12 377      0      0 123      84 260      0 38      0      0      0
User Adj:     1.00 1.00 1.00 1.00 1.00 1.00 1.00 1.00 1.00 1.00 1.00 1.00
PHF Adj:      1.00 1.00 1.00 1.00 1.00 1.00 1.00 1.00 1.00 1.00 1.00 1.00
PHF Volume:   12 377      0      0 123      84 260      0 38      0      0      0
Reduct Vol:   0      0      0      0      0      0      0      0      0      0      0      0
Reduced Vol:  12 377      0      0 123      84 260      0 38      0      0      0
PCE Adj:      1.00 1.00 1.00 1.00 1.00 1.00 1.00 1.00 1.00 1.00 1.00 1.00
MLF Adj:      1.00 1.00 1.00 1.00 1.00 1.00 1.00 1.00 1.00 1.00 1.00 1.00
Final Vol.:   12 377      0      0 123      84 260      0 38      0      0      0
-----|-----|-----|-----|
PCE Module:
AutoPCE:      12 377      0      0 123      84 260      0 38      0      0      0
TruckPCE:     0      0      0      0      0      0      0      0      0      0      0      0
ComboPCE:     0      0      0      0      0      0      0      0      0      0      0      0
BicyclePCE:   0      0      0      0      0      0      0      0      0      0      0      0
AdjVolume:    12 377      0      0 123      84 260      0 38      0      0      0
-----|-----|-----|-----|
Delay Module: >> Time Period: 0.25 hours <<
CircVolume:   260      12      123      649
MaxVolume:   1060      1194      1134      xxxxxx
PedVolume:    0      0      0      0
AdjMaxVol:   1060      1194      1134      xxxxxx
ApproachVol:  389      207      298      xxxxxx
ApproachDel:  5.4      3.6      4.3      xxxxxx
Queue:       1.7      0.6      1.1      xxxx

```

Level Of Service Computation Report
 2000 HCM Operations Method (Future Volume Alternative)

 Intersection #11 4000 North & Business Park Drive

 Cycle (sec): 60 Critical Vol./Cap. (X): 0.854
 Loss Time (sec): 0 (Y+R=4.0 sec) Average Delay (sec/veh): 20.8
 Optimal Cycle: OPTIMIZED Level Of Service: C

| Street Name: | Business Park Drive | | | | | | 4000 North | | | | | |
|--------------|---------------------|---|---|-------------|---|---|------------|---|---|-------------|---|---|
| | North Bound | | | South Bound | | | East Bound | | | West Bound | | |
| Approach: | L | T | R | L | T | R | L | T | R | L | T | R |
| Control: | Protected | | | Protected | | | Protected | | | Prot+Permit | | |
| Rights: | Include | | | Include | | | Include | | | Include | | |
| Min. Green: | 0 | 0 | 0 | 0 | 0 | 0 | 0 | 0 | 0 | 0 | 0 | 0 |
| Lanes: | 2 | 0 | 0 | 0 | 0 | 0 | 0 | 0 | 2 | 1 | 0 | 2 |

Volume Module:

| | | | | | | | | | | | | |
|--------------|------|------|------|------|------|------|------|------|------|------|------|------|
| Base Vol: | 0 | 0 | 0 | 0 | 0 | 0 | 0 | 0 | 0 | 0 | 0 | 0 |
| Growth Adj: | 1.00 | 1.00 | 1.00 | 1.00 | 1.00 | 1.00 | 1.00 | 1.00 | 1.00 | 1.00 | 1.00 | 1.00 |
| Initial Bse: | 0 | 0 | 0 | 0 | 0 | 0 | 0 | 0 | 0 | 0 | 0 | 0 |
| Added Vol: | 85 | 0 | 451 | 0 | 0 | 0 | 0 | 974 | 416 | 768 | 380 | 0 |
| PasserByVol: | 0 | 0 | 0 | 0 | 0 | 0 | 0 | 0 | 0 | 0 | 0 | 0 |
| Initial Fut: | 85 | 0 | 451 | 0 | 0 | 0 | 0 | 974 | 416 | 768 | 380 | 0 |
| User Adj: | 1.00 | 1.00 | 1.00 | 1.00 | 1.00 | 1.00 | 1.00 | 1.00 | 1.00 | 1.00 | 1.00 | 1.00 |
| PHF Adj: | 1.00 | 1.00 | 1.00 | 1.00 | 1.00 | 1.00 | 1.00 | 1.00 | 1.00 | 1.00 | 1.00 | 1.00 |
| PHF Volume: | 85 | 0 | 451 | 0 | 0 | 0 | 0 | 974 | 416 | 768 | 380 | 0 |
| Reduct Vol: | 0 | 0 | 0 | 0 | 0 | 0 | 0 | 0 | 0 | 0 | 0 | 0 |
| Reduced Vol: | 85 | 0 | 451 | 0 | 0 | 0 | 0 | 974 | 416 | 768 | 380 | 0 |
| PCE Adj: | 1.00 | 1.00 | 1.00 | 1.00 | 1.00 | 1.00 | 1.00 | 1.00 | 1.00 | 1.00 | 1.00 | 1.00 |
| MLF Adj: | 1.00 | 1.00 | 1.00 | 1.00 | 1.00 | 1.00 | 1.00 | 1.00 | 1.00 | 1.00 | 1.00 | 1.00 |
| Final Vol.: | 85 | 0 | 451 | 0 | 0 | 0 | 0 | 974 | 416 | 768 | 380 | 0 |

Saturation Flow Module:

| | | | | | | | | | | | | |
|-------------|------|------|------|------|------|------|------|------|------|------|------|------|
| Sat/Lane: | 1900 | 1900 | 1900 | 1900 | 1900 | 1900 | 1900 | 1900 | 1900 | 1900 | 1900 | 1900 |
| Adjustment: | 0.92 | 1.00 | 0.75 | 1.00 | 1.00 | 1.00 | 1.00 | 0.95 | 0.85 | 0.95 | 0.95 | 1.00 |
| Lanes: | 2.00 | 0.00 | 2.00 | 0.00 | 0.00 | 0.00 | 0.00 | 2.00 | 1.00 | 1.00 | 2.00 | 0.00 |
| Final Sat.: | 3502 | 0 | 2842 | 0 | 0 | 0 | 0 | 3610 | 1615 | 1805 | 3610 | 0 |

Capacity Analysis Module:

| | | | | | | | | | | | | |
|---------------|------|------|------|------|------|------|------|------|------|------|------|------|
| Vol/Sat: | 0.02 | 0.00 | 0.16 | 0.00 | 0.00 | 0.00 | 0.00 | 0.27 | 0.26 | 0.43 | 0.11 | 0.00 |
| Crit Moves: | | | **** | | | | | **** | | **** | | |
| Green/Cycle: | 0.19 | 0.00 | 0.19 | 0.00 | 0.00 | 0.00 | 0.00 | 0.32 | 0.32 | 0.81 | 0.81 | 0.00 |
| Volume/Cap: | 0.13 | 0.00 | 0.85 | 0.00 | 0.00 | 0.00 | 0.00 | 0.85 | 0.82 | 0.75 | 0.13 | 0.00 |
| Uniform Del: | 20.4 | 0.0 | 23.6 | 0.0 | 0.0 | 0.0 | 0.0 | 19.2 | 18.9 | 8.0 | 1.2 | 0.0 |
| IncrcmntDel: | 0.1 | 0.0 | 12.8 | 0.0 | 0.0 | 0.0 | 0.0 | 6.4 | 9.8 | 3.1 | 0.0 | 0.0 |
| InitQueueDel: | 0.0 | 0.0 | 0.0 | 0.0 | 0.0 | 0.0 | 0.0 | 0.0 | 0.0 | 0.0 | 0.0 | 0.0 |
| Delay Adj: | 1.00 | 0.00 | 1.00 | 0.00 | 0.00 | 0.00 | 0.00 | 1.00 | 1.00 | 1.00 | 1.00 | 0.00 |
| Delay/Veh: | 20.5 | 0.0 | 36.4 | 0.0 | 0.0 | 0.0 | 0.0 | 25.7 | 28.7 | 11.1 | 1.2 | 0.0 |
| User DelAdj: | 1.00 | 1.00 | 1.00 | 1.00 | 1.00 | 1.00 | 1.00 | 1.00 | 1.00 | 1.00 | 1.00 | 1.00 |
| AdjDel/Veh: | 20.5 | 0.0 | 36.4 | 0.0 | 0.0 | 0.0 | 0.0 | 25.7 | 28.7 | 11.1 | 1.2 | 0.0 |
| LOS by Move: | C | A | D | A | A | A | A | C | C | B | A | A |
| HCM2kAvgQ: | 1 | 0 | 8 | 0 | 0 | 0 | 0 | 12 | 10 | 9 | 1 | 0 |

Level of Service Computation Report

2000 HCM Unsignalized Method (Future Volume Alternative)

 Intersection #98 4000 North & Business Park Access #1

Average Delay (sec/veh): 1.0 Worst Case Level Of Service: C[15.7]

| Street Name: | Business Park Access #1 | | | | 4000 North | | | | | | | | | | | |
|--------------|-------------------------|---|-------------|---|--------------|---|--------------|---|---|---|---|---|---|---|---|---|
| | North Bound | | South Bound | | East Bound | | West Bound | | | | | | | | | |
| Approach: | North Bound | | South Bound | | East Bound | | West Bound | | | | | | | | | |
| Movement: | L | T | R | L | T | R | L | T | R | L | T | R | | | | |
| Control: | Stop Sign | | Stop Sign | | Uncontrolled | | Uncontrolled | | | | | | | | | |
| Rights: | Include | | Include | | Include | | Include | | | | | | | | | |
| Lanes: | 1 | 0 | 0 | 0 | 1 | 0 | 0 | 0 | 0 | 0 | 2 | 0 | 1 | 1 | 0 | 0 |

Volume Module:

| | | | | | | | | | | | | |
|--------------|------|------|------|------|------|------|------|------|------|------|------|------|
| Base Vol: | 0 | 0 | 0 | 0 | 0 | 0 | 0 | 0 | 0 | 0 | 0 | 0 |
| Growth Adj: | 1.00 | 1.00 | 1.00 | 1.00 | 1.00 | 1.00 | 1.00 | 1.00 | 1.00 | 1.00 | 1.00 | 1.00 |
| Initial Bse: | 0 | 0 | 0 | 0 | 0 | 0 | 0 | 0 | 0 | 0 | 0 | 0 |
| Added Vol: | 0 | 0 | 30 | 0 | 0 | 0 | 0 | 1425 | 0 | 149 | 1148 | 0 |
| PasserByVol: | 0 | 0 | 0 | 0 | 0 | 0 | 0 | 0 | 0 | 0 | 0 | 0 |
| Initial Fut: | 0 | 0 | 30 | 0 | 0 | 0 | 0 | 1425 | 0 | 149 | 1148 | 0 |
| User Adj: | 1.00 | 1.00 | 1.00 | 1.00 | 1.00 | 1.00 | 1.00 | 1.00 | 1.00 | 1.00 | 1.00 | 1.00 |
| PHF Adj: | 1.00 | 1.00 | 1.00 | 1.00 | 1.00 | 1.00 | 1.00 | 1.00 | 1.00 | 1.00 | 1.00 | 1.00 |
| PHF Volume: | 0 | 0 | 30 | 0 | 0 | 0 | 0 | 1425 | 0 | 149 | 1148 | 0 |
| Reduct Vol: | 0 | 0 | 0 | 0 | 0 | 0 | 0 | 0 | 0 | 0 | 0 | 0 |
| Final Vol.: | 0 | 0 | 30 | 0 | 0 | 0 | 0 | 1425 | 0 | 149 | 1148 | 0 |

Critical Gap Module:

| | | | | | | | | | | | | |
|--------------|-------|------|-----|-------|------|-------|-------|------|-------|-----|------|-------|
| Critical Gp: | xxxxx | xxxx | 6.9 | xxxxx | xxxx | xxxxx | xxxxx | xxxx | xxxxx | 4.1 | xxxx | xxxxx |
| FollowUpTim: | xxxxx | xxxx | 3.3 | xxxxx | xxxx | xxxxx | xxxxx | xxxx | xxxxx | 2.2 | xxxx | xxxxx |

Capacity Module:

| | | | | | | | | | | | | |
|--------------|------|------|------|------|------|-------|------|------|-------|------|------|-------|
| Cnflct Vol: | xxxx | xxxx | 713 | xxxx | xxxx | xxxxx | xxxx | xxxx | xxxxx | 1425 | xxxx | xxxxx |
| Potent Cap.: | xxxx | xxxx | 379 | xxxx | xxxx | xxxxx | xxxx | xxxx | xxxxx | 484 | xxxx | xxxxx |
| Move Cap.: | xxxx | xxxx | 379 | xxxx | xxxx | xxxxx | xxxx | xxxx | xxxxx | 484 | xxxx | xxxxx |
| Volume/Cap: | xxxx | xxxx | 0.08 | xxxx | xxxx | xxxx | xxxx | xxxx | xxxx | 0.31 | xxxx | xxxx |

Level Of Service Module:

| | | | | | | | | | | | | |
|---------------|---------------|------|---------------|-------|---------------|-------|---------------|------|---------------|-------|---------------|-------|
| 2Way95thQ: | xxxx | xxxx | 0.3 | xxxx | xxxx | xxxxx | xxxx | xxxx | xxxxx | 1.3 | xxxx | xxxxx |
| Control Del: | xxxxx | xxxx | 15.3 | xxxxx | xxxx | xxxxx | xxxxx | xxxx | xxxxx | 15.7 | xxxx | xxxxx |
| LOS by Move: | * | * | C | * | * | * | * | * | * | C | * | * |
| Movement: | LT - LTR - RT | | LT - LTR - RT | | LT - LTR - RT | | LT - LTR - RT | | LT - LTR - RT | | LT - LTR - RT | |
| Shared Cap.: | xxxx | xxxx | xxxxx | xxxx | xxxx | xxxxx | xxxx | xxxx | xxxxx | xxxx | xxxx | xxxxx |
| Shared Queue: | xxxxx | xxxx | xxxxx | xxxxx | xxxx | xxxxx | xxxxx | xxxx | xxxxx | xxxxx | xxxx | xxxxx |
| Shrd ConDel: | xxxxx | xxxx | xxxxx | xxxxx | xxxx | xxxxx | xxxxx | xxxx | xxxxx | xxxxx | xxxx | xxxxx |
| Shared LOS: | * | * | * | * | * | * | * | * | * | * | * | * |
| ApproachDel: | 15.3 | | xxxxxx | | xxxxxx | | xxxxxx | | xxxxxx | | xxxxxx | |
| ApproachLOS: | C | | * | | * | | * | | * | | * | |

 Note: Queue reported is the number of cars per lane.

Level Of Service Computation Report
 2000 HCM Operations Method (Future Volume Alternative)

 Intersection #99 4000 North & Daniels Drive

 Cycle (sec): 60 Critical Vol./Cap.(X): 0.893
 Loss Time (sec): 0 (Y+R=4.0 sec) Average Delay (sec/veh): 16.3
 Optimal Cycle: OPTIMIZED Level Of Service: B

| Street Name: | Daniels Drive | | | | | | 4000 North | | | | | |
|--------------|---------------|---|---|-------------|---|---|------------|---|---|-------------|---|---|
| | North Bound | | | South Bound | | | East Bound | | | West Bound | | |
| Approach: | L | T | R | L | T | R | L | T | R | L | T | R |
| Control: | Protected | | | Protected | | | Permitted | | | Prot+Permit | | |
| Rights: | Include | | | Include | | | Include | | | Include | | |
| Min. Green: | 0 | 0 | 0 | 0 | 0 | 0 | 0 | 0 | 0 | 0 | 0 | 0 |
| Lanes: | 1 | 0 | 0 | 0 | 0 | 0 | 0 | 2 | 0 | 1 | 0 | 0 |

| Volume Module: | | | | | | | | | | | | |
|----------------|------|------|------|------|------|------|------|------|------|------|------|------|
| Base Vol: | 0 | 0 | 0 | 0 | 0 | 0 | 0 | 0 | 0 | 0 | 0 | 0 |
| Growth Adj: | 1.00 | 1.00 | 1.00 | 1.00 | 1.00 | 1.00 | 1.00 | 1.00 | 1.00 | 1.00 | 1.00 | 1.00 |
| Initial Bse: | 0 | 0 | 0 | 0 | 0 | 0 | 0 | 0 | 0 | 0 | 0 | 0 |
| Added Vol: | 28 | 0 | 293 | 0 | 0 | 0 | 0 | 1319 | 136 | 624 | 1269 | 0 |
| PasserByVol: | 0 | 0 | 0 | 0 | 0 | 0 | 0 | 0 | 0 | 0 | 0 | 0 |
| Initial Fut: | 28 | 0 | 293 | 0 | 0 | 0 | 0 | 1319 | 136 | 624 | 1269 | 0 |
| User Adj: | 1.00 | 1.00 | 1.00 | 1.00 | 1.00 | 1.00 | 1.00 | 1.00 | 1.00 | 1.00 | 1.00 | 1.00 |
| PHF Adj: | 1.00 | 1.00 | 1.00 | 1.00 | 1.00 | 1.00 | 1.00 | 1.00 | 1.00 | 1.00 | 1.00 | 1.00 |
| PHF Volume: | 28 | 0 | 293 | 0 | 0 | 0 | 0 | 1319 | 136 | 624 | 1269 | 0 |
| Reduct Vol: | 0 | 0 | 0 | 0 | 0 | 0 | 0 | 0 | 0 | 0 | 0 | 0 |
| Reduced Vol: | 28 | 0 | 293 | 0 | 0 | 0 | 0 | 1319 | 136 | 624 | 1269 | 0 |
| PCE Adj: | 1.00 | 1.00 | 1.00 | 1.00 | 1.00 | 1.00 | 1.00 | 1.00 | 1.00 | 1.00 | 1.00 | 1.00 |
| MLF Adj: | 1.00 | 1.00 | 1.00 | 1.00 | 1.00 | 1.00 | 1.00 | 1.00 | 1.00 | 1.00 | 1.00 | 1.00 |
| Final Vol.: | 28 | 0 | 293 | 0 | 0 | 0 | 0 | 1319 | 136 | 624 | 1269 | 0 |

| Saturation Flow Module: | | | | | | | | | | | | |
|-------------------------|------|------|------|------|------|------|------|------|------|------|------|------|
| Sat/Lane: | 1900 | 1900 | 1900 | 1900 | 1900 | 1900 | 1900 | 1900 | 1900 | 1900 | 1900 | 1900 |
| Adjustment: | 0.95 | 1.00 | 0.85 | 1.00 | 1.00 | 1.00 | 1.00 | 0.95 | 0.85 | 0.95 | 0.95 | 1.00 |
| Lanes: | 1.00 | 0.00 | 1.00 | 0.00 | 0.00 | 0.00 | 0.00 | 2.00 | 1.00 | 1.00 | 2.00 | 0.00 |
| Final Sat.: | 1805 | 0 | 1615 | 0 | 0 | 0 | 0 | 3610 | 1615 | 1805 | 3610 | 0 |

| Capacity Analysis Module: | | | | | | | | | | | | |
|---------------------------|------|------|------|------|------|------|------|------|------|------|------|------|
| Vol/Sat: | 0.02 | 0.00 | 0.18 | 0.00 | 0.00 | 0.00 | 0.00 | 0.37 | 0.08 | 0.35 | 0.35 | 0.00 |
| Crit Moves: | **** | | | **** | | | **** | | | **** | | |
| Green/Cycle: | 0.20 | 0.00 | 0.20 | 0.00 | 0.00 | 0.00 | 0.00 | 0.41 | 0.41 | 0.80 | 0.80 | 0.00 |
| Volume/Cap: | 0.08 | 0.00 | 0.89 | 0.00 | 0.00 | 0.00 | 0.00 | 0.89 | 0.21 | 0.76 | 0.44 | 0.00 |
| Uniform Del: | 19.3 | 0.0 | 23.3 | 0.0 | 0.0 | 0.0 | 0.0 | 16.5 | 11.4 | 11.2 | 1.9 | 0.0 |
| IncrcmntDel: | 0.1 | 0.0 | 24.9 | 0.0 | 0.0 | 0.0 | 0.0 | 7.3 | 0.2 | 4.0 | 0.1 | 0.0 |
| InitQueuDel: | 0.0 | 0.0 | 0.0 | 0.0 | 0.0 | 0.0 | 0.0 | 0.0 | 0.0 | 0.0 | 0.0 | 0.0 |
| Delay Adj: | 1.00 | 0.00 | 1.00 | 0.00 | 0.00 | 0.00 | 0.00 | 1.00 | 1.00 | 1.00 | 1.00 | 0.00 |
| Delay/Veh: | 19.4 | 0.0 | 48.2 | 0.0 | 0.0 | 0.0 | 0.0 | 23.8 | 11.6 | 15.2 | 2.0 | 0.0 |
| User DelAdj: | 1.00 | 1.00 | 1.00 | 1.00 | 1.00 | 1.00 | 1.00 | 1.00 | 1.00 | 1.00 | 1.00 | 1.00 |
| AdjDel/Veh: | 19.4 | 0.0 | 48.2 | 0.0 | 0.0 | 0.0 | 0.0 | 23.8 | 11.6 | 15.2 | 2.0 | 0.0 |
| LOS by Move: | B | A | D | A | A | A | A | C | B | B | A | A |
| HCM2kAvgQ: | 0 | 0 | 9 | 0 | 0 | 0 | 0 | 16 | 2 | 8 | 4 | 0 |

Level Of Service Computation Report
 2000 HCM Operations Method (Future Volume Alternative)

 Intersection #102 Pole Canyon Boulevard & Daniels Drive

Cycle (sec): 60 Critical Vol./Cap.(X): 0.661
 Loss Time (sec): 0 (Y+R=4.0 sec) Average Delay (sec/veh): 2.8
 Optimal Cycle: OPTIMIZED Level Of Service: A

| Street Name: | Daniels Drive | | | | | | Pole Canyon Boulevard | | | | | |
|--------------|---------------|---|---|-------------|---|---|-----------------------|---|---|------------|---|---|
| | North Bound | | | South Bound | | | East Bound | | | West Bound | | |
| Approach: | L | T | R | L | T | R | L | T | R | L | T | R |
| Control: | Protected | | | Prot+Permit | | | Permitted | | | Protected | | |
| Rights: | Include | | | Include | | | Include | | | Include | | |
| Min. Green: | 0 | 0 | 0 | 0 | 0 | 0 | 0 | 0 | 0 | 0 | 0 | 0 |
| Lanes: | 0 | 0 | 0 | 1 | 0 | 0 | 1 | 0 | 2 | 0 | 0 | 2 |

| Volume Module: | North Bound | | | South Bound | | | East Bound | | | West Bound | | |
|----------------|-------------|------|------|-------------|------|------|------------|------|------|------------|------|------|
| Base Vol: | 0 | 0 | 0 | 0 | 0 | 0 | 0 | 0 | 0 | 0 | 0 | 0 |
| Growth Adj: | 1.00 | 1.00 | 1.00 | 1.00 | 1.00 | 1.00 | 1.00 | 1.00 | 1.00 | 1.00 | 1.00 | 1.00 |
| Initial Bse: | 0 | 0 | 0 | 0 | 0 | 0 | 0 | 0 | 0 | 0 | 0 | 0 |
| Added Vol: | 0 | 0 | 0 | 89 | 0 | 88 | 214 | 1381 | 0 | 0 | 1385 | 436 |
| PasserByVol: | 0 | 0 | 0 | 0 | 0 | 0 | 0 | 0 | 0 | 0 | 0 | 0 |
| Initial Fut: | 0 | 0 | 0 | 89 | 0 | 88 | 214 | 1381 | 0 | 0 | 1385 | 436 |
| User Adj: | 1.00 | 1.00 | 1.00 | 1.00 | 1.00 | 1.00 | 1.00 | 1.00 | 1.00 | 1.00 | 1.00 | 1.00 |
| PHF Adj: | 1.00 | 1.00 | 1.00 | 1.00 | 1.00 | 1.00 | 1.00 | 1.00 | 1.00 | 1.00 | 1.00 | 1.00 |
| PHF Volume: | 0 | 0 | 0 | 89 | 0 | 88 | 214 | 1381 | 0 | 0 | 1385 | 436 |
| Reduct Vol: | 0 | 0 | 0 | 0 | 0 | 0 | 0 | 0 | 0 | 0 | 0 | 0 |
| Reduced Vol: | 0 | 0 | 0 | 89 | 0 | 88 | 214 | 1381 | 0 | 0 | 1385 | 436 |
| PCE Adj: | 1.00 | 1.00 | 1.00 | 1.00 | 1.00 | 1.00 | 1.00 | 1.00 | 1.00 | 1.00 | 1.00 | 1.00 |
| MLF Adj: | 1.00 | 1.00 | 1.00 | 1.00 | 1.00 | 1.00 | 1.00 | 1.00 | 1.00 | 1.00 | 1.00 | 1.00 |
| Final Vol.: | 0 | 0 | 0 | 89 | 0 | 88 | 214 | 1381 | 0 | 0 | 1385 | 436 |

| Saturation Flow Module: | North Bound | | | South Bound | | | East Bound | | | West Bound | | |
|-------------------------|-------------|------|------|-------------|------|------|------------|------|------|------------|------|------|
| Sat/Lane: | 1900 | 1900 | 1900 | 1900 | 1900 | 1900 | 1900 | 1900 | 1900 | 1900 | 1900 | 1900 |
| Adjustment: | 1.00 | 1.00 | 1.00 | 0.95 | 1.00 | 0.85 | 0.18 | 0.95 | 1.00 | 1.00 | 0.95 | 0.85 |
| Lanes: | 0.00 | 0.00 | 0.00 | 1.00 | 0.00 | 1.00 | 1.00 | 2.00 | 0.00 | 0.00 | 2.00 | 1.00 |
| Final Sat.: | 0 | 0 | 0 | 1805 | 0 | 1615 | 350 | 3610 | 0 | 0 | 3610 | 1615 |

| Capacity Analysis Module: | North Bound | | | South Bound | | | East Bound | | | West Bound | | |
|---------------------------|-------------|------|------|-------------|------|------|------------|------|------|------------|------|------|
| Vol/Sat: | 0.00 | 0.00 | 0.00 | 0.05 | 0.00 | 0.05 | 0.61 | 0.38 | 0.00 | 0.00 | 0.38 | 0.27 |
| Crit Moves: | | | | **** | | | | **** | | | | |
| Green/Cycle: | 0.00 | 0.00 | 0.00 | 0.07 | 0.00 | 0.07 | 0.93 | 0.93 | 0.00 | 0.00 | 0.93 | 0.93 |
| Volume/Cap: | 0.00 | 0.00 | 0.00 | 0.66 | 0.00 | 0.73 | 0.66 | 0.41 | 0.00 | 0.00 | 0.41 | 0.29 |
| Uniform Del: | 0.0 | 0.0 | 0.0 | 27.0 | 0.0 | 27.2 | 0.4 | 0.3 | 0.0 | 0.0 | 0.3 | 0.2 |
| IncrcmntDel: | 0.0 | 0.0 | 0.0 | 11.7 | 0.0 | 20.4 | 5.0 | 0.1 | 0.0 | 0.0 | 0.1 | 0.1 |
| InitQueueDel: | 0.0 | 0.0 | 0.0 | 0.0 | 0.0 | 0.0 | 0.0 | 0.0 | 0.0 | 0.0 | 0.0 | 0.0 |
| Delay Adj: | 0.00 | 0.00 | 0.00 | 1.00 | 0.00 | 1.00 | 1.00 | 1.00 | 0.00 | 0.00 | 1.00 | 1.00 |
| Delay/Veh: | 0.0 | 0.0 | 0.0 | 38.7 | 0.0 | 47.5 | 5.5 | 0.4 | 0.0 | 0.0 | 0.4 | 0.3 |
| User DelAdj: | 1.00 | 1.00 | 1.00 | 1.00 | 1.00 | 1.00 | 1.00 | 1.00 | 1.00 | 1.00 | 1.00 | 1.00 |
| AdjDel/Veh: | 0.0 | 0.0 | 0.0 | 38.7 | 0.0 | 47.5 | 5.5 | 0.4 | 0.0 | 0.0 | 0.4 | 0.3 |
| LOS by Move: | A | A | A | D | A | D | A | A | A | A | A | A |
| HCM2kAvgQ: | 0 | 0 | 0 | 3 | 0 | 3 | 2 | 2 | 0 | 0 | 2 | 1 |

```

-----
Level Of Service Computation Report
2000 HCM Operations Method (Future Volume Alternative)
*****
Intersection #5 Pole Canyon Boulevard & Business Park Drive
*****
Cycle (sec):          60          Critical Vol./Cap.(X):          0.934
Loss Time (sec):      0 (Y+R=4.0 sec) Average Delay (sec/veh):          27.1
Optimal Cycle: OPTIMIZED          Level Of Service:          C
*****
Street Name:          Business Park Drive          Pole Canyon Boulevard
Approach:             North Bound          South Bound          East Bound          West Bound
Movement:             L - T - R          L - T - R          L - T - R          L - T - R
-----|-----|-----|-----|
Control:              Permitted          Protected          Protected          Protected
Rights:               Include          Include          Include          Include
Min. Green:           0 0 0          0 0 0          0 0 0          0 0 0
Lanes:                1 0 2 0 1      2 0 2 0 1      2 0 2 0 1      2 0 2 0 1
-----|-----|-----|-----|
Volume Module:
Base Vol:             0 0 0          0 0 0          0 0 0          0 0 0
Growth Adj:           1.00 1.00 1.00 1.00 1.00 1.00 1.00 1.00 1.00 1.00 1.00 1.00
Initial Bse:          0 0 0          0 0 0          0 0 0          0 0 0
Added Vol:            217 480 777    138 130 233    529 803 121    324 419 423
PasserByVol:         0 0 0          0 0 0          0 0 0          0 0 0
Initial Fut:          217 480 777    138 130 233    529 803 121    324 419 423
User Adj:             1.00 1.00 1.00 1.00 1.00 1.00 1.00 1.00 1.00 1.00 1.00 1.00
PHF Adj:              1.00 1.00 1.00 1.00 1.00 1.00 1.00 1.00 1.00 1.00 1.00 1.00
PHF Volume:           217 480 777    138 130 233    529 803 121    324 419 423
Reduct Vol:           0 0 0          0 0 0          0 0 0          0 0 0
Reduced Vol:          217 480 777    138 130 233    529 803 121    324 419 423
PCE Adj:              1.00 1.00 1.00 1.00 1.00 1.00 1.00 1.00 1.00 1.00 1.00 1.00
MLF Adj:              1.00 1.00 1.00 1.00 1.00 1.00 1.00 1.00 1.00 1.00 1.00 1.00
Final Vol.:           217 480 777    138 130 233    529 803 121    324 419 423
-----|-----|-----|-----|
Saturation Flow Module:
Sat/Lane:             1900 1900 1900 1900 1900 1900 1900 1900 1900 1900 1900 1900
Adjustment:           0.64 0.95 0.85 0.92 0.95 0.85 0.92 0.95 0.85 0.92 0.95 0.85
Lanes:                1.00 2.00 1.00 2.00 2.00 1.00 2.00 2.00 1.00 2.00 2.00 1.00
Final Sat.:           1220 3610 1615 3502 3610 1615 3502 3610 1615 3502 3610 1615
-----|-----|-----|-----|
Capacity Analysis Module:
Vol/Sat:              0.18 0.13 0.48 0.04 0.04 0.14 0.15 0.22 0.07 0.09 0.12 0.26
Crit Moves:          ****          ****          ****
Green/Cycle:          0.52 0.52 0.52 0.04 0.56 0.56 0.16 0.31 0.31 0.13 0.28 0.28
Volume/Cap:           0.35 0.26 0.93 0.93 0.06 0.26 0.93 0.71 0.24 0.71 0.41 0.93
Uniform Del:          8.6 8.1 13.6 28.7 6.1 6.9 24.8 18.2 15.3 25.0 17.6 21.0
IncremntDel:          0.3 0.1 17.2 54.4 0.0 0.2 22.7 2.2 0.2 5.2 0.3 26.4
InitQueueDel:         0.0 0.0 0.0 0.0 0.0 0.0 0.0 0.0 0.0 0.0 0.0 0.0
Delay Adj:             1.00 1.00 1.00 1.00 1.00 1.00 1.00 1.00 1.00 1.00 1.00 1.00
Delay/Veh:            8.9 8.2 30.8 83.0 6.1 7.0 47.5 20.4 15.6 30.2 17.8 47.5
User DelAdj:          1.00 1.00 1.00 1.00 1.00 1.00 1.00 1.00 1.00 1.00 1.00 1.00
AdjDel/Veh:           8.9 8.2 30.8 83.0 6.1 7.0 47.5 20.4 15.6 30.2 17.8 47.5
LOS by Move:          A A C F A A D C B C B D
HCM2kAvgQ:            3 3 19 4 1 2 9 8 2 5 4 12
*****

```

```

-----
Level Of Service Computation Report
2000 HCM Operations Method (Future Volume Alternative)
*****
Intersection #6 Ranch Lane & Business Park Drive
*****
Cycle (sec):          60          Critical Vol./Cap.(X):          0.660
Loss Time (sec):      0 (Y+R=4.0 sec) Average Delay (sec/veh):          9.9
Optimal Cycle: OPTIMIZED          Level Of Service:          A
*****
Street Name:          Business Park Drive          Ranch Lane
Approach:             North Bound          South Bound          East Bound          West Bound
Movement:             L - T - R          L - T - R          L - T - R          L - T - R
-----|-----|-----|-----|-----|-----|
Control:              Permitted          Permitted          Permitted          Permitted
Rights:               Include          Include          Include          Include
Min. Green:           0 0 0          0 0 0          0 0 0          0 0 0
Lanes:                1 0 1 0 1      1 0 1 0 1      1 0 1 0 1      1 0 1 0 1
-----|-----|-----|-----|-----|
Volume Module:
Base Vol:             0 0 0          0 0 0          0 0 0          0 0 0
Growth Adj:           1.00 1.00 1.00 1.00 1.00 1.00 1.00 1.00 1.00 1.00 1.00 1.00
Initial Bse:          0 0 0          0 0 0          0 0 0          0 0 0
Added Vol:            103 227 106 250 112 179 387 455 68 53 256 397
PasserByVol:         0 0 0          0 0 0          0 0 0          0 0 0
Initial Fut:          103 227 106 250 112 179 387 455 68 53 256 397
User Adj:             1.00 1.00 1.00 1.00 1.00 1.00 1.00 1.00 1.00 1.00 1.00 1.00
PHF Adj:              1.00 1.00 1.00 1.00 1.00 1.00 1.00 1.00 1.00 1.00 1.00 1.00
PHF Volume:           103 227 106 250 112 179 387 455 68 53 256 397
Reduct Vol:           0 0 0          0 0 0          0 0 0          0 0 0
Reduced Vol:          103 227 106 250 112 179 387 455 68 53 256 397
PCE Adj:              1.00 1.00 1.00 1.00 1.00 1.00 1.00 1.00 1.00 1.00 1.00 1.00
MLF Adj:              1.00 1.00 1.00 1.00 1.00 1.00 1.00 1.00 1.00 1.00 1.00 1.00
Final Vol.:           103 227 106 250 112 179 387 455 68 53 256 397
-----|-----|-----|-----|-----|
Saturation Flow Module:
Sat/Lane:             1900 1900 1900 1900 1900 1900 1900 1900 1900 1900 1900 1900
Adjustment:           0.62 1.00 0.85 0.48 1.00 0.85 0.53 1.00 0.85 0.38 1.00 0.85
Lanes:                1.00 1.00 1.00 1.00 1.00 1.00 1.00 1.00 1.00 1.00 1.00 1.00
Final Sat.:           1172 1900 1615 920 1900 1615 998 1900 1615 722 1900 1615
-----|-----|-----|-----|-----|
Capacity Analysis Module:
Vol/Sat:              0.09 0.12 0.07 0.27 0.06 0.11 0.39 0.24 0.04 0.07 0.13 0.25
Crit Moves:          ****          ****
Green/Cycle:          0.41 0.41 0.41 0.41 0.41 0.41 0.59 0.59 0.59 0.59 0.59 0.59
Volume/Cap:           0.21 0.29 0.16 0.66 0.14 0.27 0.66 0.41 0.07 0.12 0.23 0.42
Uniform Del:           11.4 11.8 11.1 14.2 11.0 11.7 8.3 6.7 5.3 5.5 5.9 6.8
IncrmntDel:           0.2 0.2 0.1 4.3 0.1 0.2 2.8 0.2 0.0 0.1 0.1 0.3
InitQueuDel:          0.0 0.0 0.0 0.0 0.0 0.0 0.0 0.0 0.0 0.0 0.0 0.0
Delay Adj:            1.00 1.00 1.00 1.00 1.00 1.00 1.00 1.00 1.00 1.00 1.00 1.00
Delay/Veh:            11.6 12.0 11.2 18.5 11.1 11.9 11.1 6.9 5.3 5.6 6.0 7.1
User DelAdj:          1.00 1.00 1.00 1.00 1.00 1.00 1.00 1.00 1.00 1.00 1.00 1.00
AdjDel/Veh:           11.6 12.0 11.2 18.5 11.1 11.9 11.1 6.9 5.3 5.6 6.0 7.1
LOS by Move:         B B B B B B B A A A A A
HCM2kAvgQ:            1 3 1 5 1 2 6 5 1 1 2 4
*****

```

Level of Service Computation Report
 2000 HCM Operations Method (Future Volume Alternative)

 Intersection #7 SR-73 & 4000 North

Cycle (sec): 60 Critical Vol./Cap.(X): 0.889
 Loss Time (sec): 0 (Y+R=4.0 sec) Average Delay (sec/veh): 20.2
 Optimal Cycle: OPTIMIZED Level Of Service: C

| Street Name: | SR-73 | | | | | | 4000 North | | | | | |
|--------------|-------------|---|---|-------------|---|---|-------------|---|---|-------------|---|---|
| | North Bound | | | South Bound | | | East Bound | | | West Bound | | |
| Approach: | L | T | R | L | T | R | L | T | R | L | T | R |
| Movement: | | | | | | | | | | | | |
| Control: | Prot+Permit | | | Protected | | | Prot+Permit | | | Prot+Permit | | |
| Rights: | Include | | | Include | | | Include | | | Include | | |
| Min. Green: | 0 | 0 | 0 | 0 | 0 | 0 | 0 | 0 | 0 | 0 | 0 | 0 |
| Lanes: | 1 | 0 | 2 | 0 | 2 | 0 | 1 | 0 | 0 | 1 | 0 | 1 |

Volume Module:

| | | | | | | | | | | | | |
|--------------|------|------|------|------|------|------|------|------|------|------|------|------|
| Base Vol: | 0 | 145 | 0 | 0 | 74 | 0 | 0 | 0 | 0 | 0 | 0 | 0 |
| Growth Adj: | 2.33 | 2.33 | 2.33 | 2.33 | 2.33 | 2.33 | 2.33 | 2.33 | 2.33 | 2.33 | 2.33 | 2.33 |
| Initial Bse: | 0 | 338 | 0 | 0 | 172 | 0 | 0 | 0 | 0 | 0 | 0 | 0 |
| Added Vol: | 19 | 1227 | 305 | 137 | 1448 | 394 | 225 | 336 | 11 | 421 | 586 | 514 |
| PasserByVol: | 0 | 0 | 0 | 0 | 0 | 0 | 0 | 0 | 0 | 0 | 0 | 0 |
| Initial Fut: | 19 | 1565 | 305 | 137 | 1620 | 394 | 225 | 336 | 11 | 421 | 586 | 514 |
| User Adj: | 1.00 | 1.00 | 1.00 | 1.00 | 1.00 | 1.00 | 1.00 | 1.00 | 1.00 | 1.00 | 1.00 | 1.00 |
| PHF Adj: | 1.00 | 1.00 | 1.00 | 1.00 | 1.00 | 1.00 | 1.00 | 1.00 | 1.00 | 1.00 | 1.00 | 1.00 |
| PHF Volume: | 19 | 1565 | 305 | 137 | 1620 | 394 | 225 | 336 | 11 | 421 | 586 | 514 |
| Reduct Vol: | 0 | 0 | 0 | 0 | 0 | 0 | 0 | 0 | 0 | 0 | 0 | 0 |
| Reduced Vol: | 19 | 1565 | 305 | 137 | 1620 | 394 | 225 | 336 | 11 | 421 | 586 | 514 |
| PCE Adj: | 1.00 | 1.00 | 1.00 | 1.00 | 1.00 | 1.00 | 1.00 | 1.00 | 1.00 | 1.00 | 1.00 | 1.00 |
| MLF Adj: | 1.00 | 1.00 | 1.00 | 1.00 | 1.00 | 1.00 | 1.00 | 1.00 | 1.00 | 1.00 | 1.00 | 1.00 |
| Final Vol.: | 19 | 1565 | 305 | 137 | 1620 | 394 | 225 | 336 | 11 | 421 | 586 | 514 |

Saturation Flow Module:

| | | | | | | | | | | | | |
|-------------|------|------|------|------|------|------|------|------|------|------|------|------|
| Sat/Lane: | 1900 | 1900 | 1900 | 1900 | 1900 | 1900 | 1900 | 1900 | 1900 | 1900 | 1900 | 1900 |
| Adjustment: | 0.95 | 0.95 | 0.85 | 0.92 | 0.95 | 0.85 | 0.95 | 1.00 | 1.00 | 0.95 | 0.88 | 0.88 |
| Lanes: | 1.00 | 2.00 | 1.00 | 2.00 | 2.00 | 1.00 | 1.00 | 0.97 | 0.03 | 1.00 | 1.60 | 1.40 |
| Final Sat.: | 1805 | 3610 | 1615 | 3502 | 3610 | 1615 | 1805 | 1831 | 60 | 1805 | 2683 | 2353 |

Capacity Analysis Module:

| | | | | | | | | | | | | |
|---------------|------|------|------|------|------|------|------|------|------|------|------|------|
| Vol/Sat: | 0.01 | 0.43 | 0.19 | 0.04 | 0.45 | 0.24 | 0.12 | 0.18 | 0.18 | 0.23 | 0.22 | 0.22 |
| Crit Moves: | **** | | | **** | | | **** | | | **** | | |
| Green/Cycle: | 0.53 | 0.49 | 0.49 | 0.04 | 0.52 | 0.52 | 0.38 | 0.21 | 0.21 | 0.47 | 0.30 | 0.30 |
| Volume/Cap: | 0.13 | 0.89 | 0.39 | 0.89 | 0.86 | 0.47 | 0.51 | 0.89 | 0.89 | 0.70 | 0.73 | 0.73 |
| Uniform Del: | 6.7 | 13.9 | 9.7 | 28.5 | 12.6 | 9.2 | 13.4 | 23.1 | 23.1 | 12.3 | 18.9 | 18.9 |
| IncrementDel: | 0.4 | 6.0 | 0.3 | 42.0 | 4.5 | 0.4 | 1.0 | 21.4 | 21.4 | 3.7 | 1.9 | 1.9 |
| InitQueueDel: | 0.0 | 0.0 | 0.0 | 0.0 | 0.0 | 0.0 | 0.0 | 0.0 | 0.0 | 0.0 | 0.0 | 0.0 |
| Delay Adj: | 1.00 | 1.00 | 1.00 | 1.00 | 1.00 | 1.00 | 1.00 | 1.00 | 1.00 | 1.00 | 1.00 | 1.00 |
| Delay/Veh: | 7.0 | 20.0 | 10.0 | 70.5 | 17.1 | 9.6 | 14.4 | 44.5 | 44.5 | 16.0 | 20.8 | 20.8 |
| User DelAdj: | 1.00 | 1.00 | 1.00 | 1.00 | 1.00 | 1.00 | 1.00 | 1.00 | 1.00 | 1.00 | 1.00 | 1.00 |
| AdjDel/Veh: | 7.0 | 20.0 | 10.0 | 70.5 | 17.1 | 9.6 | 14.4 | 44.5 | 44.5 | 16.0 | 20.8 | 20.8 |
| LOS by Move: | A | B | B | E | B | A | B | D | D | B | C | C |
| HCM2kAvgQ: | 0 | 18 | 4 | 4 | 17 | 5 | 4 | 10 | 10 | 8 | 8 | 8 |

```

-----
Level Of Service Computation Report
2000 HCM Operations Method (Future Volume Alternative)
*****
Intersection #8 SR-73 & Pole Canyon Boulevard
*****
Cycle (sec):          60          Critical Vol./Cap.(X):          0.827
Loss Time (sec):      0 (Y+R=4.0 sec) Average Delay (sec/veh):          20.5
Optimal Cycle: OPTIMIZED          Level Of Service:          C
*****
Street Name:          SR-73          Pole Canyon Boulevard
Approach:             North Bound    South Bound    East Bound    West Bound
Movement:             L - T - R    L - T - R    L - T - R    L - T - R
-----|-----|-----|-----|
Control:              Prot+Permit    Protected    Permitted    Permitted
Rights:               Include       Include       Include       Include
Min. Green:           0 0 0         0 0 0         0 0 0         0 0 0
Lanes:                1 0 2 0 1     2 0 2 0 1     1 0 1 0 1     1 0 1 0 1
-----|-----|-----|-----|
Volume Module:
Base Vol:             0 145 0         0 74 0         0 0 0         0 0 0
Growth Adj:           2.33 2.33 2.33 2.33 2.33 2.33 2.33 2.33 2.33 2.33 2.33 2.33
Initial Bse:          0 338 0         0 172 0         0 0 0         0 0 0
Added Vol:            166 550 164     516 863 501     311 254 119     208 416 689
PasserByVol:         0 0 0         0 0 0         0 0 0         0 0 0
Initial Fut:         166 888 164     516 1035 501     311 254 119     208 416 689
User Adj:             1.00 1.00 1.00 1.00 1.00 1.00 1.00 1.00 1.00 1.00 1.00 1.00
PHF Adj:              1.00 1.00 1.00 1.00 1.00 1.00 1.00 1.00 1.00 1.00 1.00 1.00
PHF Volume:          166 888 164     516 1035 501     311 254 119     208 416 689
Reduct Vol:           0 0 0         0 0 0         0 0 0         0 0 0
Reduced Vol:         166 888 164     516 1035 501     311 254 119     208 416 689
PCE Adj:              1.00 1.00 1.00 1.00 1.00 1.00 1.00 1.00 1.00 1.00 1.00 1.00
MLF Adj:              1.00 1.00 1.00 1.00 1.00 1.00 1.00 1.00 1.00 1.00 1.00 1.00
Final Vol.:           166 888 164     516 1035 501     311 254 119     208 416 689
-----|-----|-----|-----|
Saturation Flow Module:
Sat/Lane:             1900 1900 1900 1900 1900 1900 1900 1900 1900 1900 1900 1900
Adjustment:           0.95 0.95 0.85 0.92 0.95 0.85 0.38 1.00 0.85 0.51 1.00 0.85
Lanes:                1.00 2.00 1.00 2.00 2.00 1.00 1.00 1.00 1.00 1.00 1.00 1.00
Final Sat.:           1805 3610 1615 3502 3610 1615 716 1900 1615 961 1900 1615
-----|-----|-----|-----|
Capacity Analysis Module:
Vol/Sat:              0.09 0.25 0.10 0.15 0.29 0.31 0.43 0.13 0.07 0.22 0.22 0.43
Crit Moves:          ****          ****          ****
Green/Cycle:          0.48 0.30 0.30 0.18 0.37 0.37 0.52 0.52 0.52 0.52 0.52 0.52
Volume/Cap:           0.51 0.83 0.34 0.83 0.78 0.85 0.83 0.25 0.14 0.41 0.42 0.81
Uniform Del:          13.0 19.7 16.5 23.8 16.9 17.4 12.0 7.8 7.3 8.6 8.7 11.8
IncremntDel:          1.4 5.4 0.4 9.0 3.1 10.9 14.1 0.1 0.1 0.5 0.3 6.0
InitQueuDel:          0.0 0.0 0.0 0.0 0.0 0.0 0.0 0.0 0.0 0.0 0.0 0.0
Delay Adj:            1.00 1.00 1.00 1.00 1.00 1.00 1.00 1.00 1.00 1.00 1.00 1.00
Delay/Veh:            14.4 25.1 16.9 32.8 20.0 28.3 26.1 8.0 7.4 9.2 9.0 17.9
User DelAdj:          1.00 1.00 1.00 1.00 1.00 1.00 1.00 1.00 1.00 1.00 1.00 1.00
AdjDel/Veh:           14.4 25.1 16.9 32.8 20.0 28.3 26.1 8.0 7.4 9.2 9.0 17.9
LOS by Move:          B C B C B C C A A A A B
HCM2kAvqQ:            3 11 3 8 11 12 8 3 1 3 5 13
*****

```

Level of Service Computation Report
 2000 HCM Unsignalized Method (Future Volume Alternative)

 Intersection #84 SR-73 & Commercial Access #1

Average Delay (sec/veh): 1.1 Worst Case Level Of Service: D[29.1]

| Approach: | North Bound | | | South Bound | | | East Bound | | | West Bound | | |
|-----------|--------------|---|---|--------------|---|---|------------|---|---|------------|---|---|
| Movement: | L | T | R | L | T | R | L | T | R | L | T | R |
| Control: | Uncontrolled | | | Uncontrolled | | | Stop Sign | | | Stop Sign | | |
| Rights: | Include | | | Include | | | Include | | | Include | | |
| Lanes: | 0 | 0 | 1 | 0 | 1 | 0 | 0 | 0 | 0 | 1 | 0 | 0 |

Volume Module:

| | | | | | | | | | | | | |
|--------------|------|------|------|------|------|------|------|------|------|------|------|------|
| Base Vol: | 0 | 145 | 0 | 0 | 74 | 0 | 0 | 0 | 0 | 0 | 0 | 0 |
| Growth Adj: | 2.33 | 2.33 | 2.33 | 2.33 | 2.33 | 2.33 | 2.33 | 2.33 | 2.33 | 2.33 | 2.33 | 2.33 |
| Initial Bse: | 0 | 338 | 0 | 0 | 172 | 0 | 0 | 0 | 0 | 0 | 0 | 0 |
| Added Vol: | 0 | 811 | 2 | 65 | 1125 | 0 | 0 | 0 | 0 | 2 | 0 | 70 |
| PasserByVol: | 0 | 0 | 0 | 0 | 0 | 0 | 0 | 0 | 0 | 0 | 0 | 0 |
| Initial Fut: | 0 | 1149 | 2 | 65 | 1297 | 0 | 0 | 0 | 0 | 2 | 0 | 70 |
| User Adj: | 1.00 | 1.00 | 1.00 | 1.00 | 1.00 | 1.00 | 1.00 | 1.00 | 1.00 | 1.00 | 1.00 | 1.00 |
| PHF Adj: | 1.00 | 1.00 | 1.00 | 1.00 | 1.00 | 1.00 | 1.00 | 1.00 | 1.00 | 1.00 | 1.00 | 1.00 |
| PHF Volume: | 0 | 1149 | 2 | 65 | 1297 | 0 | 0 | 0 | 0 | 2 | 0 | 70 |
| Reduct Vol: | 0 | 0 | 0 | 0 | 0 | 0 | 0 | 0 | 0 | 0 | 0 | 0 |
| Final Vol.: | 0 | 1149 | 2 | 65 | 1297 | 0 | 0 | 0 | 0 | 2 | 0 | 70 |

Critical Gap Module:

| | | | | | | | | | | | | |
|--------------|-------|------|-------|-----|------|-------|-------|------|-------|-----|------|-----|
| Critical Gp: | xxxxx | xxxx | xxxxx | 4.1 | xxxx | xxxxx | xxxxx | xxxx | xxxxx | 6.4 | xxxx | 6.2 |
| FollowUpTim: | xxxxx | xxxx | xxxxx | 2.2 | xxxx | xxxxx | xxxxx | xxxx | xxxxx | 3.5 | xxxx | 3.3 |

Capacity Module:

| | | | | | | | | | | | | |
|--------------|------|------|-------|------|------|-------|------|------|-------|------|------|------|
| Cnflct Vol: | xxxx | xxxx | xxxxx | 1151 | xxxx | xxxxx | xxxx | xxxx | xxxxx | 2576 | xxxx | 1149 |
| Potent Cap.: | xxxx | xxxx | xxxxx | 614 | xxxx | xxxxx | xxxx | xxxx | xxxxx | 29 | xxxx | 244 |
| Move Cap.: | xxxx | xxxx | xxxxx | 614 | xxxx | xxxxx | xxxx | xxxx | xxxxx | 26 | xxxx | 244 |
| Volume/Cap: | xxxx | xxxx | xxxx | 0.11 | xxxx | xxxx | xxxx | xxxx | xxxx | 0.08 | xxxx | 0.29 |

Level Of Service Module:

| | | | | | | | | | | | | |
|--------------|---------|------|-------|---------|------|-------|---------|------|-------|-------|------|-------|
| 2Way95thQ: | xxxx | xxxx | xxxxx | 0.4 | xxxx | xxxxx | xxxx | xxxx | xxxxx | 0.2 | xxxx | 1.1 |
| Control Del: | xxxxx | xxxx | xxxxx | 11.6 | xxxx | xxxxx | xxxxx | xxxx | xxxxx | 152.0 | xxxx | 25.6 |
| LOS by Move: | * | * | * | B | * | * | * | * | * | F | * | D |
| Movement: | LT | LTR | RT | LT | LTR | RT | LT | LTR | RT | LT | LTR | RT |
| Shared Cap.: | xxxx | xxxx | xxxxx | xxxx | xxxx | xxxxx | xxxx | xxxx | xxxxx | xxxx | xxxx | xxxxx |
| SharedQueue: | xxxxx | xxxx | xxxxx | xxxxx | xxxx | xxxxx | xxxxx | xxxx | xxxxx | xxxxx | xxxx | xxxxx |
| Shrd ConDel: | xxxxx | xxxx | xxxxx | xxxxx | xxxx | xxxxx | xxxxx | xxxx | xxxxx | xxxxx | xxxx | xxxxx |
| Shared LOS: | * | * | * | * | * | * | * | * | * | * | * | * |
| ApproachDel: | xxxxxxx | | | xxxxxxx | | | xxxxxxx | | | 29.1 | | |
| ApproachLOS: | * | | | * | | | * | | | D | | |

Note: Queue reported is the number of cars per lane.

Level Of Service Computation Report

2000 HCM Unsignalized Method (Future Volume Alternative)

Intersection #85 SR-73 & Commercial Access #2

Average Delay (sec/veh): 1.2 Worst Case Level Of Service: D[29.0]

| Approach: | North Bound | | | | South Bound | | | | East Bound | | | | West Bound | | | | | | | |
|-----------|--------------|---|---|---|--------------|---|---|---|------------|---|---|---|------------|---|---|---|---|---|---|---|
| Movement: | L | T | R | | L | T | R | | L | T | R | | L | T | R | | | | | |
| Control: | Uncontrolled | | | | Uncontrolled | | | | Stop Sign | | | | Stop Sign | | | | | | | |
| Rights: | Include | | | | Include | | | | Include | | | | Include | | | | | | | |
| Lanes: | 0 | 0 | 1 | 0 | 1 | 1 | 0 | 1 | 0 | 0 | 0 | 0 | 0 | 0 | 0 | 1 | 0 | 0 | 0 | 1 |

Volume Module:

| | | | | | | | | | | | | | | | |
|--------------|------|------|------|------|------|------|------|------|------|------|------|------|------|------|------|
| Base Vol: | 0 | 145 | 0 | 0 | 74 | 0 | 0 | 0 | 0 | 0 | 0 | 0 | 0 | 0 | 0 |
| Growth Adj: | 2.33 | 2.33 | 2.33 | 2.33 | 2.33 | 2.33 | 2.33 | 2.33 | 2.33 | 2.33 | 2.33 | 2.33 | 2.33 | 2.33 | 2.33 |
| Initial Bse: | 0 | 338 | 0 | 0 | 172 | 0 | 0 | 0 | 0 | 0 | 0 | 0 | 0 | 0 | 0 |
| Added Vol: | 0 | 742 | 4 | 65 | 1062 | 0 | 0 | 0 | 0 | 4 | 0 | 71 | 0 | 0 | 0 |
| PasserByVol: | 0 | 0 | 0 | 0 | 0 | 0 | 0 | 0 | 0 | 0 | 0 | 0 | 0 | 0 | 0 |
| Initial Fut: | 0 | 1080 | 4 | 65 | 1234 | 0 | 0 | 0 | 0 | 4 | 0 | 71 | 0 | 0 | 0 |
| User Adj: | 1.00 | 1.00 | 1.00 | 1.00 | 1.00 | 1.00 | 1.00 | 1.00 | 1.00 | 1.00 | 1.00 | 1.00 | 1.00 | 1.00 | 1.00 |
| PHF Adj: | 1.00 | 1.00 | 1.00 | 1.00 | 1.00 | 1.00 | 1.00 | 1.00 | 1.00 | 1.00 | 1.00 | 1.00 | 1.00 | 1.00 | 1.00 |
| PHF Volume: | 0 | 1080 | 4 | 65 | 1234 | 0 | 0 | 0 | 0 | 4 | 0 | 71 | 0 | 0 | 0 |
| Reduct Vol: | 0 | 0 | 0 | 0 | 0 | 0 | 0 | 0 | 0 | 0 | 0 | 0 | 0 | 0 | 0 |
| Final Vol.: | 0 | 1080 | 4 | 65 | 1234 | 0 | 0 | 0 | 0 | 4 | 0 | 71 | 0 | 0 | 0 |

Critical Gap Module:

| | | | | | | | | | | | | |
|--------------|-------|------|-------|-----|------|-------|-------|------|-------|-----|------|-----|
| Critical Gp: | xxxxx | xxxx | xxxxx | 4.1 | xxxx | xxxxx | xxxxx | xxxx | xxxxx | 6.4 | xxxx | 6.2 |
| FollowUpTim: | xxxxx | xxxx | xxxxx | 2.2 | xxxx | xxxxx | xxxxx | xxxx | xxxxx | 3.5 | xxxx | 3.3 |

Capacity Module:

| | | | | | | | | | | | | |
|--------------|------|------|-------|------|------|-------|------|------|-------|------|------|------|
| Cnflct Vol: | xxxx | xxxx | xxxxx | 1084 | xxxx | xxxxx | xxxx | xxxx | xxxxx | 2444 | xxxx | 1080 |
| Potent Cap.: | xxxx | xxxx | xxxxx | 651 | xxxx | xxxxx | xxxx | xxxx | xxxxx | 35 | xxxx | 268 |
| Move Cap.: | xxxx | xxxx | xxxxx | 651 | xxxx | xxxxx | xxxx | xxxx | xxxxx | 32 | xxxx | 268 |
| Volume/Cap: | xxxx | xxxx | xxxx | 0.10 | xxxx | xxxx | xxxx | xxxx | xxxx | 0.12 | xxxx | 0.27 |

Level Of Service Module:

| | | | | | | | | | | | | |
|--------------|---------|------|-------|---------|------|-------|---------|------|-------|-------|------|-------|
| 2Way95thQ: | xxxx | xxxx | xxxxx | 0.3 | xxxx | xxxxx | xxxx | xxxx | xxxxx | 0.4 | xxxx | 1.0 |
| Control Del: | xxxxx | xxxx | xxxxx | 11.1 | xxxx | xxxxx | xxxxx | xxxx | xxxxx | 131.8 | xxxx | 23.2 |
| LOS by Move: | * | * | * | B | * | * | * | * | * | F | * | C |
| Movement: | LT | LTR | RT | LT | LTR | RT | LT | LTR | RT | LT | LTR | RT |
| Shared Cap.: | xxxx | xxxx | xxxxx | xxxx | xxxx | xxxxx | xxxx | xxxx | xxxxx | xxxx | xxxx | xxxxx |
| SharedQueue: | xxxxx | xxxx | xxxxx | xxxxx | xxxx | xxxxx | xxxxx | xxxx | xxxxx | xxxxx | xxxx | xxxxx |
| Shrd ConDel: | xxxxx | xxxx | xxxxx | xxxxx | xxxx | xxxxx | xxxxx | xxxx | xxxxx | xxxxx | xxxx | xxxxx |
| Shared LOS: | * | * | * | * | * | * | * | * | * | * | * | * |
| ApproachDel: | xxxxxxx | | | xxxxxxx | | | xxxxxxx | | | 29.0 | | |
| ApproachLOS: | * | | | * | | | * | | | D | | |

Note: Queue reported is the number of cars per lane.

Level Of Service Computation Report
 2000 HCM Unsignalized Method (Future Volume Alternative)

 Intersection #35 SR-73 & Residential Access

Average Delay (sec/veh): 1.1 Worst Case Level Of Service: D[29.7]

| Approach: | North Bound | | | | | South Bound | | | | | East Bound | | | | | West Bound | | | | |
|-----------|--------------|---|---|---|---|--------------|---|---|---|---|------------|---|---|---|---|------------|---|---|---|---|
| Movement: | L - T - R | | | | | L - T - R | | | | | L - T - R | | | | | L - T - R | | | | |
| Control: | Uncontrolled | | | | | Uncontrolled | | | | | Stop Sign | | | | | Stop Sign | | | | |
| Rights: | Include | | | | | Include | | | | | Include | | | | | Include | | | | |
| Lanes: | 0 | 0 | 1 | 0 | 1 | 1 | 0 | 1 | 0 | 0 | 0 | 0 | 0 | 0 | 0 | 1 | 0 | 0 | 0 | 1 |

Volume Module:

| | | | | | | | | | | | | | | | | | | | | | | |
|--------------|------|------|------|------|------|------|------|------|------|------|------|------|------|------|------|------|------|------|------|------|------|------|
| Base Vol: | 0 | 145 | 0 | 0 | 74 | 0 | 0 | 0 | 0 | 0 | 0 | 0 | 0 | 0 | 0 | 0 | 0 | 0 | 0 | 0 | 0 | 0 |
| Growth Adj: | 2.33 | 2.33 | 2.33 | 2.33 | 2.33 | 2.33 | 2.33 | 2.33 | 2.33 | 2.33 | 2.33 | 2.33 | 2.33 | 2.33 | 2.33 | 2.33 | 2.33 | 2.33 | 2.33 | 2.33 | 2.33 | 2.33 |
| Initial Bse: | 0 | 338 | 0 | 0 | 172 | 0 | 0 | 0 | 0 | 0 | 0 | 0 | 0 | 0 | 0 | 0 | 0 | 0 | 0 | 0 | 0 | 0 |
| Added Vol: | 0 | 697 | 9 | 84 | 981 | 0 | 0 | 0 | 0 | 0 | 0 | 0 | 0 | 0 | 5 | 0 | 0 | 0 | 0 | 0 | 0 | 48 |
| PasserByVol: | 0 | 0 | 0 | 0 | 0 | 0 | 0 | 0 | 0 | 0 | 0 | 0 | 0 | 0 | 0 | 0 | 0 | 0 | 0 | 0 | 0 | 0 |
| Initial Fut: | 0 | 1035 | 9 | 84 | 1153 | 0 | 0 | 0 | 0 | 0 | 0 | 0 | 0 | 0 | 5 | 0 | 0 | 0 | 0 | 0 | 0 | 48 |
| User Adj: | 1.00 | 1.00 | 1.00 | 1.00 | 1.00 | 1.00 | 1.00 | 1.00 | 1.00 | 1.00 | 1.00 | 1.00 | 1.00 | 1.00 | 1.00 | 1.00 | 1.00 | 1.00 | 1.00 | 1.00 | 1.00 | 1.00 |
| PHF Adj: | 1.00 | 1.00 | 1.00 | 1.00 | 1.00 | 1.00 | 1.00 | 1.00 | 1.00 | 1.00 | 1.00 | 1.00 | 1.00 | 1.00 | 1.00 | 1.00 | 1.00 | 1.00 | 1.00 | 1.00 | 1.00 | 1.00 |
| PHF Volume: | 0 | 1035 | 9 | 84 | 1153 | 0 | 0 | 0 | 0 | 0 | 0 | 0 | 0 | 0 | 5 | 0 | 0 | 0 | 0 | 0 | 0 | 48 |
| Reduct Vol: | 0 | 0 | 0 | 0 | 0 | 0 | 0 | 0 | 0 | 0 | 0 | 0 | 0 | 0 | 0 | 0 | 0 | 0 | 0 | 0 | 0 | 0 |
| Final Vol.: | 0 | 1035 | 9 | 84 | 1153 | 0 | 0 | 0 | 0 | 0 | 0 | 0 | 0 | 0 | 5 | 0 | 0 | 0 | 0 | 0 | 0 | 48 |

Critical Gap Module:

| | | | | | | | | | | | | |
|--------------|-------|------|-------|-----|------|-------|-------|------|-------|-----|------|-----|
| Critical Gp: | xxxxx | xxxx | xxxxx | 4.1 | xxxx | xxxxx | xxxxx | xxxx | xxxxx | 6.4 | xxxx | 6.2 |
| FollowUpTim: | xxxxx | xxxx | xxxxx | 2.2 | xxxx | xxxxx | xxxxx | xxxx | xxxxx | 3.5 | xxxx | 3.3 |

Capacity Module:

| | | | | | | | | | | | | |
|--------------|------|------|-------|------|------|-------|------|------|-------|------|------|------|
| Cnflct Vol: | xxxx | xxxx | xxxxx | 1044 | xxxx | xxxxx | xxxx | xxxx | xxxxx | 2356 | xxxx | 1035 |
| Potent Cap.: | xxxx | xxxx | xxxxx | 674 | xxxx | xxxxx | xxxx | xxxx | xxxxx | 40 | xxxx | 284 |
| Move Cap.: | xxxx | xxxx | xxxxx | 674 | xxxx | xxxxx | xxxx | xxxx | xxxxx | 36 | xxxx | 284 |
| Volume/Cap: | xxxx | xxxx | xxxx | 0.12 | xxxx | xxxx | xxxx | xxxx | xxxx | 0.14 | xxxx | 0.17 |

Level Of Service Module:

| | | | | | | | | | | | | |
|---------------|---------------|------|---------|---------------|---------|-------|---------------|------|-------|---------------|------|-------|
| 2Way95thQ: | xxxx | xxxx | xxxxx | 0.4 | xxxx | xxxxx | xxxx | xxxx | xxxxx | 0.4 | xxxx | 0.6 |
| Control Del: | xxxxx | xxxx | xxxxx | 11.1 | xxxx | xxxxx | xxxxx | xxxx | xxxxx | 120.7 | xxxx | 20.2 |
| LOS by Move: | * | * | * | B | * | * | * | * | * | F | * | C |
| Movement: | LT - LTR - RT | | | LT - LTR - RT | | | LT - LTR - RT | | | LT - LTR - RT | | |
| Shared Cap.: | xxxx | xxxx | xxxxx | xxxx | xxxx | xxxxx | xxxx | xxxx | xxxxx | xxxx | xxxx | xxxxx |
| Shared Queue: | xxxxx | xxxx | xxxxx | xxxxx | xxxx | xxxxx | xxxxx | xxxx | xxxxx | xxxxx | xxxx | xxxxx |
| Shrd ConDel: | xxxxx | xxxx | xxxxx | xxxxx | xxxx | xxxxx | xxxxx | xxxx | xxxxx | xxxxx | xxxx | xxxxx |
| Shared LOS: | * | * | * | * | * | * | * | * | * | * | * | * |
| ApproachDel: | xxxxxxx | | xxxxxxx | | xxxxxxx | | xxxxxxx | | 29.7 | | | |
| ApproachLOS: | * | | * | | * | | * | | D | | | |

Note: Queue reported is the number of cars per lane.

Level Of Service Computation Report
 2000 HCM Operations Method (Future Volume Alternative)

 Intersection #9 SR-73 & Ranch Lane

Cycle (sec): 60 Critical Vol./Cap.(X): 1.014
 Loss Time (sec): 0 (Y+R=4.0 sec) Average Delay (sec/veh): 23.4
 Optimal Cycle: OPTIMIZED Level Of Service: C

| Street Name: | SR-73 | | | | | | Ranch Lane | | | | | | |
|--------------|-------------|---|---|-------------|---|---|-------------|---|---|-------------|---|---|---|
| | North Bound | | | South Bound | | | East Bound | | | West Bound | | | |
| Approach: | L | T | R | L | T | R | L | T | R | L | T | R | |
| Movement: | | | | | | | | | | | | | |
| Control: | Permitted | | | Permitted | | | Prot+Permit | | | Prot+Permit | | | |
| Rights: | Include | | | Include | | | Include | | | Include | | | |
| Min. Green: | 0 | 0 | 0 | 0 | 0 | 0 | 0 | 0 | 0 | 0 | 0 | 0 | |
| Lanes: | 1 | 0 | 1 | 0 | 1 | 0 | 1 | 1 | 0 | 0 | 1 | 0 | 1 |

Volume Module:

| | | | | | | | | | | | | |
|--------------|------|------|------|------|------|------|------|------|------|------|------|------|
| Base Vol: | 0 | 145 | 0 | 0 | 74 | 0 | 0 | 0 | 0 | 0 | 0 | 0 |
| Growth Adj: | 2.33 | 2.33 | 2.33 | 2.33 | 2.33 | 2.33 | 2.33 | 2.33 | 2.33 | 2.33 | 2.33 | 2.33 |
| Initial Bse: | 0 | 338 | 0 | 0 | 172 | 0 | 0 | 0 | 0 | 0 | 0 | 0 |
| Added Vol: | 186 | 227 | 306 | 363 | 244 | 379 | 216 | 161 | 107 | 462 | 282 | 263 |
| PasserByVol: | 0 | 0 | 0 | 0 | 0 | 0 | 0 | 0 | 0 | 0 | 0 | 0 |
| Initial Fut: | 186 | 565 | 306 | 363 | 416 | 379 | 216 | 161 | 107 | 462 | 282 | 263 |
| User Adj: | 1.00 | 1.00 | 1.00 | 1.00 | 1.00 | 1.00 | 1.00 | 1.00 | 1.00 | 1.00 | 1.00 | 1.00 |
| PHF Adj: | 1.00 | 1.00 | 1.00 | 1.00 | 1.00 | 1.00 | 1.00 | 1.00 | 1.00 | 1.00 | 1.00 | 1.00 |
| PHF Volume: | 186 | 565 | 306 | 363 | 416 | 379 | 216 | 161 | 107 | 462 | 282 | 263 |
| Reduct Vol: | 0 | 0 | 0 | 0 | 0 | 0 | 0 | 0 | 0 | 0 | 0 | 0 |
| Reduced Vol: | 186 | 565 | 306 | 363 | 416 | 379 | 216 | 161 | 107 | 462 | 282 | 263 |
| PCE Adj: | 1.00 | 1.00 | 1.00 | 1.00 | 1.00 | 1.00 | 1.00 | 1.00 | 1.00 | 1.00 | 1.00 | 1.00 |
| MLF Adj: | 1.00 | 1.00 | 1.00 | 1.00 | 1.00 | 1.00 | 1.00 | 1.00 | 1.00 | 1.00 | 1.00 | 1.00 |
| Final Vol.: | 186 | 565 | 306 | 363 | 416 | 379 | 216 | 161 | 107 | 462 | 282 | 263 |

Saturation Flow Module:

| | | | | | | | | | | | | |
|-------------|------|------|------|------|------|------|------|------|------|------|------|------|
| Sat/Lane: | 1900 | 1900 | 1900 | 1900 | 1900 | 1900 | 1900 | 1900 | 1900 | 1900 | 1900 | 1900 |
| Adjustment: | 0.41 | 1.00 | 0.85 | 0.31 | 1.00 | 0.85 | 0.95 | 0.94 | 0.94 | 0.93 | 1.00 | 0.85 |
| Lanes: | 1.00 | 1.00 | 1.00 | 1.00 | 1.00 | 1.00 | 1.00 | 0.60 | 0.40 | 1.00 | 1.00 | 1.00 |
| Final Sat.: | 787 | 1900 | 1615 | 593 | 1900 | 1615 | 1805 | 1073 | 713 | 1770 | 1900 | 1615 |

Capacity Analysis Module:

| | | | | | | | | | | | | |
|---------------|------|------|------|------|------|------|------|------|------|------|------|------|
| Vol/Sat: | 0.24 | 0.30 | 0.19 | 0.61 | 0.22 | 0.23 | 0.12 | 0.15 | 0.15 | 0.26 | 0.15 | 0.16 |
| Crit Moves: | | | | **** | | | | **** | | | | |
| Green/Cycle: | 0.60 | 0.60 | 0.60 | 0.60 | 0.60 | 0.60 | 0.32 | 0.15 | 0.15 | 0.40 | 0.23 | 0.23 |
| Volume/Cap: | 0.39 | 0.49 | 0.32 | 1.02 | 0.36 | 0.39 | 0.50 | 1.02 | 1.02 | 0.80 | 0.65 | 0.71 |
| Uniform Del: | 6.2 | 6.8 | 5.9 | 12.0 | 6.1 | 6.2 | 16.1 | 25.6 | 25.6 | 14.6 | 20.9 | 21.3 |
| IncramntDel: | 0.5 | 0.3 | 0.2 | 52.4 | 0.2 | 0.3 | 0.9 | 60.3 | 60.3 | 7.6 | 3.3 | 6.2 |
| InitQueueDel: | 0.0 | 0.0 | 0.0 | 0.0 | 0.0 | 0.0 | 0.0 | 0.0 | 0.0 | 0.0 | 0.0 | 0.0 |
| Delay Adj: | 1.00 | 1.00 | 1.00 | 1.00 | 1.00 | 1.00 | 1.00 | 1.00 | 1.00 | 1.00 | 1.00 | 1.00 |
| Delay/Veh: | 6.8 | 7.1 | 6.1 | 64.4 | 6.3 | 6.5 | 17.0 | 85.8 | 85.8 | 22.1 | 24.2 | 27.5 |
| User DelAdj: | 1.00 | 1.00 | 1.00 | 1.00 | 1.00 | 1.00 | 1.00 | 1.00 | 1.00 | 1.00 | 1.00 | 1.00 |
| AdjDel/Veh: | 6.8 | 7.1 | 6.1 | 64.4 | 6.3 | 6.5 | 17.0 | 85.8 | 85.8 | 22.1 | 24.2 | 27.5 |
| LOS by Move: | A | A | A | E | A | A | B | F | F | C | C | C |
| HCM2kAvgQ: | 2 | 6 | 3 | 13 | 4 | 4 | 4 | 11 | 11 | 10 | 6 | 6 |

```

-----
Level Of Service Computation Report
FHWA Roundabout Method (Future Volume Alternative)
*****
Intersection #1 Westhoff Way & Pole Canyon Loop South
*****
Average Delay (sec/veh):      5.0      Level Of Service: A
*****
Street Name:      Westhoff Way      Pole Canyon Circle South
Approach:      North Bound      South Bound      East Bound      West Bound
Movement:      L - T - R      L - T - R      L - T - R      L - T - R
-----|-----|-----|-----|
Control:      Yield Sign      Yield Sign      Yield Sign      Yield Sign
Lanes:      1      1      1      1
-----|-----|-----|-----|
Volume Module:
Base Vol:      0 0 0 0 0 0 0 0 0 0 0 0
Growth Adj:  1.00 1.00 1.00 1.00 1.00 1.00 1.00 1.00 1.00 1.00 1.00 1.00
Initial Bse:  0 0 0 0 0 0 0 0 0 0 0 0
Added Vol:   108 283 111 95 162 0 0 12 62 71 22 166
PasserByVol:  0 0 0 0 0 0 0 0 0 0 0 0
Initial Fut: 108 283 111 95 162 0 0 12 62 71 22 166
User Adj:    1.00 1.00 1.00 1.00 1.00 1.00 1.00 1.00 1.00 1.00 1.00 1.00
PHF Adj:     1.00 1.00 1.00 1.00 1.00 1.00 1.00 1.00 1.00 1.00 1.00 1.00
PHF Volume:  108 283 111 95 162 0 0 12 62 71 22 166
Reduct Vol:  0 0 0 0 0 0 0 0 0 0 0 0
Reduced Vol: 108 283 111 95 162 0 0 12 62 71 22 166
PCE Adj:     1.00 1.00 1.00 1.00 1.00 1.00 1.00 1.00 1.00 1.00 1.00 1.00
MLF Adj:     1.00 1.00 1.00 1.00 1.00 1.00 1.00 1.00 1.00 1.00 1.00 1.00
Final Vol.:  108 283 111 95 162 0 0 12 62 71 22 166
-----|-----|-----|-----|
PCE Module:
AutoPCE:     108 283 111 95 162 0 0 12 62 71 22 166
TruckPCE:    0 0 0 0 0 0 0 0 0 0 0 0
ComboPCE:    0 0 0 0 0 0 0 0 0 0 0 0
BicyclePCE:  0 0 0 0 0 0 0 0 0 0 0 0
AdjVolume:   108 283 111 95 162 0 0 12 62 71 22 166
-----|-----|-----|-----|
Delay Module: >> Time Period: 0.25 hours <<
CircVolume:  107      201      328      391
MaxVolume:   1142     1091     1023     989
PedVolume:    0         0         0         0
AdjMaxVol:   1142     1091     1023     989
ApproachVol: 502      257      74       259
ApproachDel: 5.6      4.3      3.8      4.9
Queue:       2.3      0.9      0.2      1.1

```

Level Of Service Computation Report

FHWA Roundabout Method (Future Volume Alternative)

Intersection #2 Westhoff Way & Pole Canyon Loop North

Average Delay (sec/veh): 11.1 Level Of Service: B

Street Name: Westhoff Way Pole Canyon Circle North

Approach: North Bound South Bound East Bound West Bound

Movement: L - T - R L - T - R L - T - R L - T - R

Control: Yield Sign Yield Sign Yield Sign Yield Sign
 Lanes: 1 1 1 1

Volume Module:

| | | | | | | | | | | | | |
|--------------|------|------|------|------|------|------|------|------|------|------|------|------|
| Base Vol: | 0 | 0 | 0 | 0 | 0 | 0 | 0 | 0 | 0 | 0 | 0 | 0 |
| Growth Adj: | 1.00 | 1.00 | 1.00 | 1.00 | 1.00 | 1.00 | 1.00 | 1.00 | 1.00 | 1.00 | 1.00 | 1.00 |
| Initial Bse: | 0 | 0 | 0 | 0 | 0 | 0 | 0 | 0 | 0 | 0 | 0 | 0 |
| Added Vol: | 16 | 189 | 11 | 339 | 108 | 0 | 0 | 160 | 9 | 20 | 280 | 593 |
| PasserByVol: | 0 | 0 | 0 | 0 | 0 | 0 | 0 | 0 | 0 | 0 | 0 | 0 |
| Initial Fut: | 16 | 189 | 11 | 339 | 108 | 0 | 0 | 160 | 9 | 20 | 280 | 593 |
| User Adj: | 1.00 | 1.00 | 1.00 | 1.00 | 1.00 | 1.00 | 1.00 | 1.00 | 1.00 | 1.00 | 1.00 | 1.00 |
| PHF Adj: | 1.00 | 1.00 | 1.00 | 1.00 | 1.00 | 1.00 | 1.00 | 1.00 | 1.00 | 1.00 | 1.00 | 1.00 |
| PHF Volume: | 16 | 189 | 11 | 339 | 108 | 0 | 0 | 160 | 9 | 20 | 280 | 593 |
| Reduct Vol: | 0 | 0 | 0 | 0 | 0 | 0 | 0 | 0 | 0 | 0 | 0 | 0 |
| Reduced Vol: | 16 | 189 | 11 | 339 | 108 | 0 | 0 | 160 | 9 | 20 | 280 | 593 |
| PCE Adj: | 1.00 | 1.00 | 1.00 | 1.00 | 1.00 | 1.00 | 1.00 | 1.00 | 1.00 | 1.00 | 1.00 | 1.00 |
| MLF Adj: | 1.00 | 1.00 | 1.00 | 1.00 | 1.00 | 1.00 | 1.00 | 1.00 | 1.00 | 1.00 | 1.00 | 1.00 |
| Final Vol.: | 16 | 189 | 11 | 339 | 108 | 0 | 0 | 160 | 9 | 20 | 280 | 593 |

PCE Module:

| | | | | | | | | | | | | |
|-------------|----|-----|----|-----|-----|---|---|-----|---|----|-----|-----|
| AutoPCE: | 16 | 189 | 11 | 339 | 108 | 0 | 0 | 160 | 9 | 20 | 280 | 593 |
| TruckPCE: | 0 | 0 | 0 | 0 | 0 | 0 | 0 | 0 | 0 | 0 | 0 | 0 |
| ComboPCE: | 0 | 0 | 0 | 0 | 0 | 0 | 0 | 0 | 0 | 0 | 0 | 0 |
| BicyclePCE: | 0 | 0 | 0 | 0 | 0 | 0 | 0 | 0 | 0 | 0 | 0 | 0 |
| AdjVolume: | 16 | 189 | 11 | 339 | 108 | 0 | 0 | 160 | 9 | 20 | 280 | 593 |

Delay Module: >> Time Period: 0.25 hours <<

| | | | | |
|--------------|-----|------|-----|------|
| CircVolume: | 499 | 316 | 467 | 205 |
| MaxVolume: | 931 | 1029 | 948 | 1089 |
| PedVolume: | 0 | 0 | 0 | 0 |
| AdjMaxVol: | 931 | 1029 | 948 | 1089 |
| ApproachVol: | 216 | 447 | 169 | 893 |
| ApproachDel: | 5.0 | 6.2 | 4.6 | 16.3 |
| Queue: | 0.9 | 2.2 | 0.6 | 9.8 |

```

-----
Level Of Service Computation Report
FHWA Roundabout Method (Future Volume Alternative)
*****
Intersection #3 Smith Lane & Pole Canyon Loop
*****
Average Delay (sec/veh):      6.0      Level Of Service: A
*****
Street Name:      Smith Lane      Pole Canyon Loop
Approach:      North Bound      South Bound      East Bound      West Bound
Movement:      L - T - R      L - T - R      L - T - R      L - T - R
-----|-----|-----|-----|
Control:      Yield Sign      Yield Sign      Yield Sign      Yield Sign
Lanes:      1      1      1      1
-----|-----|-----|-----|
Volume Module:
Base Vol:      0 0 0 0 0 0 0 0 0 0 0 0
Growth Adj: 1.00 1.00 1.00 1.00 1.00 1.00 1.00 1.00 1.00 1.00 1.00 1.00
Initial Bse: 0 0 0 0 0 0 0 0 0 0 0 0
Added Vol: 354 168 0 0 96 365 209 0 202 0 0 0
PasserByVol: 0 0 0 0 0 0 0 0 0 0 0 0
Initial Fut: 354 168 0 0 96 365 209 0 202 0 0 0
User Adj: 1.00 1.00 1.00 1.00 1.00 1.00 1.00 1.00 1.00 1.00 1.00 1.00
PHF Adj: 1.00 1.00 1.00 1.00 1.00 1.00 1.00 1.00 1.00 1.00 1.00 1.00
PHF Volume: 354 168 0 0 96 365 209 0 202 0 0 0
Reduct Vol: 0 0 0 0 0 0 0 0 0 0 0 0
Reduced Vol: 354 168 0 0 96 365 209 0 202 0 0 0
PCE Adj: 1.00 1.00 1.00 1.00 1.00 1.00 1.00 1.00 1.00 1.00 1.00 1.00
MLF Adj: 1.00 1.00 1.00 1.00 1.00 1.00 1.00 1.00 1.00 1.00 1.00 1.00
Final Vol.: 354 168 0 0 96 365 209 0 202 0 0 0
-----|-----|-----|-----|
PCE Module:
AutoPCE: 354 168 0 0 96 365 209 0 202 0 0 0
TruckPCE: 0 0 0 0 0 0 0 0 0 0 0 0
ComboPCE: 0 0 0 0 0 0 0 0 0 0 0 0
BicyclePCE: 0 0 0 0 0 0 0 0 0 0 0 0
AdjVolume: 354 168 0 0 96 365 209 0 202 0 0 0
-----|-----|-----|-----|
Delay Module: >> Time Period: 0.25 hours <<
CircVolume: 209 354 96 731
MaxVolume: 1087 1009 1148 xxxxxx
PedVolume: 0 0 0 0
AdjMaxVol: 1087 1009 1148 xxxxxx
ApproachVol: 522 461 411 xxxxxx
ApproachDel: 6.3 6.5 4.9 xxxxxx
Queue: 2.7 2.4 1.6 xxxx

```

```

-----
Level Of Service Computation Report
FHWA Roundabout Method (Future Volume Alternative)
*****
Intersection #4 Pole Canyon Boulevard & Pole Canyon Loop
*****
Average Delay (sec/veh):      6.4      Level Of Service: A
*****
Street Name:      Pole Canyon Boulevard      Pole Canyon Loop
Approach:      North Bound      South Bound      East Bound      West Bound
Movement:      L - T - R      L - T - R      L - T - R      L - T - R
-----|-----|-----|-----|
Control:      Yield Sign      Yield Sign      Yield Sign      Yield Sign
Lanes:      1      1      1      1
-----|-----|-----|-----|
Volume Module:
Base Vol:      0      0      0      0      0      0      0      0      0      0      0      0
Growth Adj:  1.00 1.00 1.00 1.00 1.00 1.00 1.00 1.00 1.00 1.00 1.00 1.00
Initial Bse:  0      0      0      0      0      0      0      0      0      0      0      0
Added Vol:    42 242  0      0 422 292 167  0 24  0  0  0
PasserByVol:  0      0      0      0  0  0      0      0  0  0  0  0
Initial Fut:  42 242  0      0 422 292 167  0 24  0  0  0
User Adj:    1.00 1.00 1.00 1.00 1.00 1.00 1.00 1.00 1.00 1.00 1.00 1.00
PHF Adj:     1.00 1.00 1.00 1.00 1.00 1.00 1.00 1.00 1.00 1.00 1.00 1.00
PHF Volume:  42 242  0      0 422 292 167  0 24  0  0  0
Reduct Vol:  0      0      0      0  0  0      0      0  0  0  0  0
Reduced Vol: 42 242  0      0 422 292 167  0 24  0  0  0
PCE Adj:     1.00 1.00 1.00 1.00 1.00 1.00 1.00 1.00 1.00 1.00 1.00 1.00
MLF Adj:     1.00 1.00 1.00 1.00 1.00 1.00 1.00 1.00 1.00 1.00 1.00 1.00
Final Vol.:  42 242  0      0 422 292 167  0 24  0  0  0
-----|-----|-----|-----|
PCE Module:
AutoPCE:     42 242  0      0 422 292 167  0 24  0  0  0
TruckPCE:    0      0      0      0  0  0      0      0  0  0  0  0
ComboPCE:    0      0      0      0  0  0      0      0  0  0  0  0
BicyclePCE:  0      0      0      0  0  0      0      0  0  0  0  0
AdjVolume:   42 242  0      0 422 292 167  0 24  0  0  0
-----|-----|-----|-----|
Delay Module: >> Time Period: 0.25 hours <<
CircVolume:   167      42      422      451
MaxVolume:   1110     1177     972     xxxxxx
PedVolume:    0      0      0      0
AdjMaxVol:   1110     1177     972     xxxxxx
ApproachVol: 284      714     191     xxxxxx
ApproachDel: 4.4      7.7      4.6     xxxxxx
Queue:       1.0      4.3      0.7     xxxx

```

```

-----
Level Of Service Computation Report
2000 HCM Operations Method (Future Volume Alternative)
*****
Intersection #11 4000 North & Business Park Drive
*****
Cycle (sec):          60          Critical Vol./Cap.(X):          0.834
Loss Time (sec):      0 (Y+R=4.0 sec) Average Delay (sec/veh):          16.2
Optimal Cycle: OPTIMIZED          Level Of Service:          B
*****
Street Name:          Business Park Drive          4000 North
Approach:              North Bound          South Bound          East Bound          West Bound
Movement:              L - T - R          L - T - R          L - T - R          L - T - R
-----|-----|-----|-----|
Control:               Protected          Protected          Protected          Prot+Permit
Rights:                Include          Include          Include          Include
Min. Green:            0 0 0          0 0 0          0 0 0          0 0 0
Lanes:                 2 0 0 0 2          0 0 0 0 0          0 0 2 0 1          1 0 2 0 0
-----|-----|-----|-----|
Volume Module:
Base Vol:              0 0 0          0 0 0          0 0 0          0 0 0
Growth Adj:            1.00 1.00 1.00 1.00 1.00 1.00 1.00 1.00 1.00 1.00 1.00 1.00
Initial Bse:           0 0 0          0 0 0          0 0 0          0 0 0
Added Vol:             409 0 912          0 0 0          0 668 109 592 1112 0
PasserByVol:          0 0 0          0 0 0          0 0 0          0 0 0
Initial Fut:           409 0 912          0 0 0          0 668 109 592 1112 0
User Adj:              1.00 1.00 1.00 1.00 1.00 1.00 1.00 1.00 1.00 1.00 1.00 1.00
PHF Adj:              1.00 1.00 1.00 1.00 1.00 1.00 1.00 1.00 1.00 1.00 1.00 1.00
PHF Volume:           409 0 912          0 0 0          0 668 109 592 1112 0
Reduct Vol:           0 0 0          0 0 0          0 0 0          0 0 0
Reduced Vol:          409 0 912          0 0 0          0 668 109 592 1112 0
PCE Adj:              1.00 1.00 1.00 1.00 1.00 1.00 1.00 1.00 1.00 1.00 1.00 1.00
MLF Adj:              1.00 1.00 1.00 1.00 1.00 1.00 1.00 1.00 1.00 1.00 1.00 1.00
Final Vol.:           409 0 912          0 0 0          0 668 109 592 1112 0
-----|-----|-----|-----|
Saturation Flow Module:
Sat/Lane:             1900 1900 1900 1900 1900 1900 1900 1900 1900 1900 1900 1900
Adjustment:           0.92 1.00 0.75 1.00 1.00 1.00 1.00 0.95 0.85 0.95 0.95 1.00
Lanes:                2.00 0.00 2.00 0.00 0.00 0.00 0.00 2.00 1.00 1.00 2.00 0.00
Final Sat.:           3502 0 2842          0 0 0          0 3610 1615 1805 3610 0
-----|-----|-----|-----|
Capacity Analysis Module:
Vol/Sat:              0.12 0.00 0.32 0.00 0.00 0.00 0.00 0.19 0.07 0.33 0.31 0.00
Crit Moves:           ****          ****          ****
Green/Cycle:          0.38 0.00 0.38 0.00 0.00 0.00 0.00 0.22 0.22 0.62 0.62 0.00
Volume/Cap:           0.30 0.00 0.83 0.00 0.00 0.00 0.00 0.83 0.30 0.71 0.50 0.00
Uniform Del:          12.9 0.0 16.7 0.0 0.0 0.0 0.0 22.3 19.5 8.1 6.4 0.0
IncrmntDel:           0.1 0.0 5.6 0.0 0.0 0.0 0.0 7.5 0.5 2.8 0.2 0.0
InitQueuDel:          0.0 0.0 0.0 0.0 0.0 0.0 0.0 0.0 0.0 0.0 0.0 0.0
Delay Adj:            1.00 0.00 1.00 0.00 0.00 0.00 0.00 1.00 1.00 1.00 1.00 0.00
Delay/Veh:            13.0 0.0 22.4 0.0 0.0 0.0 0.0 29.8 20.0 11.0 6.6 0.0
User DelAdj:          1.00 1.00 1.00 1.00 1.00 1.00 1.00 1.00 1.00 1.00 1.00 1.00
AdjDel/Veh:           13.0 0.0 22.4 0.0 0.0 0.0 0.0 29.8 20.0 11.0 6.6 0.0
LOS by Move:          B A C A A A A C B B A A
HCM2kAvgQ:            3 0 12 0 0 0 0 9 2 9 6 0
*****

```

Level Of Service Computation Report

2000 HCM Unsignalized Method (Future Volume Alternative)

Intersection #98 4000 North & Business Park Access #1

Average Delay (sec/veh): 1.2 Worst Case Level Of Service: C[23.6]

Street Name: Business Park Access #1 4000 North

Approach: North Bound South Bound East Bound West Bound

Movement: L - T - R L - T - R L - T - R L - T - R

Control: Stop Sign Stop Sign Uncontrolled Uncontrolled

Rights: Include Include Include Include

Lanes: 1 0 0 0 1 0 0 0 0 0 0 0 2 0 1 1 0 2 0 0

Volume Module:

Table with 13 columns for traffic movements and rows for Base Vol, Growth Adj, Initial Bse, Added Vol, PasserByVol, Initial Fut, User Adj, PHF Adj, PHF Volume, Reduct Vol, Final Vol.

Critical Gap Module:

Table with 13 columns for traffic movements and rows for Critical Gp, FollowUpTim.

Capacity Module:

Table with 13 columns for traffic movements and rows for Cnflct Vol, Potent Cap., Move Cap., Volume/Cap.

Level Of Service Module:

Table with 13 columns for traffic movements and rows for 2Way95thQ, Control Del, LOS by Move, Movement, Shared Cap., SharedQueue, Shrd ConDel, Shared LOS, ApproachDel, ApproachLOS.

Note: Queue reported is the number of cars per lane.

```

-----
Level Of Service Computation Report
2000 HCM Operations Method (Future Volume Alternative)
*****
Intersection #99 4000 North & Daniels Drive
*****
Cycle (sec):          60          Critical Vol./Cap.(X):          1.033
Loss Time (sec):      0 (Y+R=4.0 sec) Average Delay (sec/veh):          33.1
Optimal Cycle: OPTIMIZED          Level Of Service:          C
*****
Street Name:          Daniels Drive          4000 North
Approach:             North Bound          South Bound          East Bound          West Bound
Movement:             L - T - R          L - T - R          L - T - R          L - T - R
-----|-----|-----|-----|
Control:              Protected          Protected          Protected          Prot+Permit
Rights:               Include          Include          Include          Include
Min. Green:           0 0 0          0 0 0          0 0 0          0 0 0
Lanes:                1 0 0 0 1          0 0 0 0 0          0 0 2 0 1          1 0 2 0 0
-----|-----|-----|-----|
Volume Module:
Base Vol:             0 0 0          0 0 0          0 0 0          0 0 0
Growth Adj:           1.00 1.00 1.00 1.00 1.00 1.00 1.00 1.00 1.00 1.00 1.00 1.00
Initial Bse:          0 0 0          0 0 0          0 0 0          0 0 0
Added Vol:            134 0 635          0 0 0          0 1691 36 322 1609 0
PasserByVol:         0 0 0          0 0 0          0 0 0          0 0 0
Initial Fut:          134 0 635          0 0 0          0 1691 36 322 1609 0
User Adj:             1.00 1.00 1.00 1.00 1.00 1.00 1.00 1.00 1.00 1.00 1.00 1.00
PHF Adj:              1.00 1.00 1.00 1.00 1.00 1.00 1.00 1.00 1.00 1.00 1.00 1.00
PHF Volume:           134 0 635          0 0 0          0 1691 36 322 1609 0
Reduct Vol:           0 0 0          0 0 0          0 0 0          0 0 0
Reduced Vol:          134 0 635          0 0 0          0 1691 36 322 1609 0
PCE Adj:              1.00 1.00 1.00 1.00 1.00 1.00 1.00 1.00 1.00 1.00 1.00 1.00
MLF Adj:              1.00 1.00 1.00 1.00 1.00 1.00 1.00 1.00 1.00 1.00 1.00 1.00
Final Vol.:           134 0 635          0 0 0          0 1691 36 322 1609 0
-----|-----|-----|-----|
Saturation Flow Module:
Sat/Lane:             1900 1900 1900 1900 1900 1900 1900 1900 1900 1900 1900 1900
Adjustment:           0.95 1.00 0.85 1.00 1.00 1.00 1.00 0.95 0.85 0.79 0.95 1.00
Lanes:                1.00 0.00 1.00 0.00 0.00 0.00 0.00 2.00 1.00 1.00 2.00 0.00
Final Sat.:           1805 0 1615          0 0 0          0 3610 1615 1494 3610 0
-----|-----|-----|-----|
Capacity Analysis Module:
Vol/Sat:              0.07 0.00 0.39 0.00 0.00 0.00 0.00 0.47 0.02 0.22 0.45 0.00
Crit Moves:          *****          *****          *****
Green/Cycle:          0.38 0.00 0.38 0.00 0.00 0.00 0.00 0.45 0.45 0.62 0.62 0.00
Volume/Cap:           0.20 0.00 1.04 0.00 0.00 0.00 0.00 1.04 0.05 0.74 0.72 0.00
Uniform Del:          12.5 0.0 18.7 0.0 0.0 0.0 0.0 0.0 16.5 9.3 5.2 7.7 0.0
IncremntDel:          0.1 0.0 47.2 0.0 0.0 0.0 0.0 0.0 33.5 0.0 6.5 1.1 0.0
InitQueuDel:          0.0 0.0 0.0 0.0 0.0 0.0 0.0 0.0 0.0 0.0 0.0 0.0 0.0
Delay Adj:            1.00 0.00 1.00 0.00 0.00 0.00 0.00 1.00 1.00 1.00 1.00 0.00
Delay/Veh:            12.7 0.0 65.9 0.0 0.0 0.0 0.0 0.0 50.0 9.3 11.8 8.9 0.0
User DelAdj:          1.00 1.00 1.00 1.00 1.00 1.00 1.00 1.00 1.00 1.00 1.00 1.00
AdjDel/Veh:           12.7 0.0 65.9 0.0 0.0 0.0 0.0 0.0 50.0 9.3 11.8 8.9 0.0
LOS by Move:          B A E A A A A D A B A A
HCM2kAvgQ:            2 0 21 0 0 0 0 0 28 0 6 12 0
*****

```

Level Of Service Computation Report
 2000 HCM Operations Method (Future Volume Alternative)

Intersection #102 Pole Canyon Boulevard & Daniels Drive

Cycle (sec): 60 Critical Vol./Cap.(X): 0.753

Loss Time (sec): 0 (Y+R=4.0 sec) Average Delay (sec/veh): 8.9

Optimal Cycle: OPTIMIZED Level Of Service: A

| Street Name: | Daniels Drive | | | | | | Pole Canyon Boulevard | | | | | |
|--------------|---------------|---|---|-------------|---|---|-----------------------|---|---|------------|---|---|
| | North Bound | | | South Bound | | | East Bound | | | West Bound | | |
| Approach: | North Bound | | | South Bound | | | East Bound | | | West Bound | | |
| Movement: | L | T | R | L | T | R | L | T | R | L | T | R |
| Control: | Protected | | | Protected | | | Permitted | | | Permitted | | |
| Rights: | Include | | | Include | | | Include | | | Include | | |
| Min. Green: | 0 | 0 | 0 | 0 | 0 | 0 | 0 | 0 | 0 | 0 | 0 | 0 |
| Lanes: | 0 | 0 | 0 | 1 | 0 | 0 | 1 | 0 | 2 | 0 | 0 | 2 |

Volume Module:

| | | | | | | | | | | | | |
|--------------|------|------|------|------|------|------|------|------|------|------|------|------|
| Base Vol: | 0 | 0 | 0 | 0 | 0 | 0 | 0 | 0 | 0 | 0 | 0 | 0 |
| Growth Adj: | 1.00 | 1.00 | 1.00 | 1.00 | 1.00 | 1.00 | 1.00 | 1.00 | 1.00 | 1.00 | 1.00 | 1.00 |
| Initial Bse: | 0 | 0 | 0 | 0 | 0 | 0 | 0 | 0 | 0 | 0 | 0 | 0 |
| Added Vol: | 0 | 0 | 0 | 428 | 0 | 206 | 98 | 1686 | 0 | 0 | 1562 | 114 |
| PasserByVol: | 0 | 0 | 0 | 0 | 0 | 0 | 0 | 0 | 0 | 0 | 0 | 0 |
| Initial Fut: | 0 | 0 | 0 | 428 | 0 | 206 | 98 | 1686 | 0 | 0 | 1562 | 114 |
| User Adj: | 1.00 | 1.00 | 1.00 | 1.00 | 1.00 | 1.00 | 1.00 | 1.00 | 1.00 | 1.00 | 1.00 | 1.00 |
| PHF Adj: | 1.00 | 1.00 | 1.00 | 1.00 | 1.00 | 1.00 | 1.00 | 1.00 | 1.00 | 1.00 | 1.00 | 1.00 |
| PHF Volume: | 0 | 0 | 0 | 428 | 0 | 206 | 98 | 1686 | 0 | 0 | 1562 | 114 |
| Reduct Vol: | 0 | 0 | 0 | 0 | 0 | 0 | 0 | 0 | 0 | 0 | 0 | 0 |
| Reduced Vol: | 0 | 0 | 0 | 428 | 0 | 206 | 98 | 1686 | 0 | 0 | 1562 | 114 |
| PCE Adj: | 1.00 | 1.00 | 1.00 | 1.00 | 1.00 | 1.00 | 1.00 | 1.00 | 1.00 | 1.00 | 1.00 | 1.00 |
| MLF Adj: | 1.00 | 1.00 | 1.00 | 1.00 | 1.00 | 1.00 | 1.00 | 1.00 | 1.00 | 1.00 | 1.00 | 1.00 |
| Final Vol.: | 0 | 0 | 0 | 428 | 0 | 206 | 98 | 1686 | 0 | 0 | 1562 | 114 |

Saturation Flow Module:

| | | | | | | | | | | | | |
|-------------|------|------|------|------|------|------|------|------|------|------|------|------|
| Sat/Lane: | 1900 | 1900 | 1900 | 1900 | 1900 | 1900 | 1900 | 1900 | 1900 | 1900 | 1900 | 1900 |
| Adjustment: | 1.00 | 1.00 | 1.00 | 0.95 | 1.00 | 0.85 | 0.10 | 0.95 | 1.00 | 1.00 | 0.95 | 0.85 |
| Lanes: | 0.00 | 0.00 | 0.00 | 1.00 | 0.00 | 1.00 | 1.00 | 2.00 | 0.00 | 0.00 | 2.00 | 1.00 |
| Final Sat.: | 0 | 0 | 0 | 1805 | 0 | 1615 | 190 | 3610 | 0 | 0 | 3610 | 1615 |

Capacity Analysis Module:

| | | | | | | | | | | | | | |
|--------------|------|------|------|------|------|------|------|------|------|------|------|------|--|
| Vol/Sat: | 0.00 | 0.00 | 0.00 | 0.24 | 0.00 | 0.13 | 0.52 | 0.47 | 0.00 | 0.00 | 0.43 | 0.07 | |
| Crit Moves: | | | | **** | | | | **** | | | | | |
| Green/Cycle: | 0.00 | 0.00 | 0.00 | 0.31 | 0.00 | 0.31 | 0.69 | 0.69 | 0.00 | 0.00 | 0.69 | 0.69 | |
| Volume/Cap: | 0.00 | 0.00 | 0.00 | 0.75 | 0.00 | 0.41 | 0.75 | 0.68 | 0.00 | 0.00 | 0.63 | 0.10 | |
| Uniform Del: | 0.0 | 0.0 | 0.0 | 18.5 | 0.0 | 16.1 | 6.1 | 5.6 | 0.0 | 0.0 | 5.2 | 3.2 | |
| IncramntDel: | 0.0 | 0.0 | 0.0 | 5.6 | 0.0 | 0.5 | 21.7 | 0.8 | 0.0 | 0.0 | 0.5 | 0.0 | |
| InitQueuDel: | 0.0 | 0.0 | 0.0 | 0.0 | 0.0 | 0.0 | 0.0 | 0.0 | 0.0 | 0.0 | 0.0 | 0.0 | |
| Delay Adj: | 0.00 | 0.00 | 0.00 | 1.00 | 0.00 | 1.00 | 1.00 | 1.00 | 0.00 | 0.00 | 1.00 | 1.00 | |
| Delay/Veh: | 0.0 | 0.0 | 0.0 | 24.1 | 0.0 | 16.7 | 27.8 | 6.4 | 0.0 | 0.0 | 5.8 | 3.2 | |
| User DelAdj: | 1.00 | 1.00 | 1.00 | 1.00 | 1.00 | 1.00 | 1.00 | 1.00 | 1.00 | 1.00 | 1.00 | 1.00 | |
| AdjDel/Veh: | 0.0 | 0.0 | 0.0 | 24.1 | 0.0 | 16.7 | 27.8 | 6.4 | 0.0 | 0.0 | 5.8 | 3.2 | |
| LOS by Move: | A | A | A | C | A | B | C | A | A | A | A | A | |
| HCM2kAvgQ: | 0 | 0 | 0 | 9 | 0 | 3 | 3 | 11 | 0 | 0 | 9 | 1 | |

Level Of Service Computation Report

2000 HCM Operations Method (Future Volume Alternative)

Intersection #5 Pole Canyon Boulevard & Business Park Drive

Cycle (sec): 60 Critical Vol./Cap.(X): 0.899

Loss Time (sec): 0 (Y+R=4.0 sec) Average Delay (sec/veh): 27.0

Optimal Cycle: OPTIMIZED Level Of Service: C

| Street Name: | Business Park Drive | | | | | | Pole Canyon Boulevard | | | | | | | | |
|--------------|---------------------|---|---|-------------|---|---|-----------------------|---|---|------------|---|---|---|---|---|
| | North Bound | | | South Bound | | | East Bound | | | West Bound | | | | | |
| Approach: | L | T | R | L | T | R | L | T | R | L | T | R | | | |
| Movement: | L | T | R | L | T | R | L | T | R | L | T | R | | | |
| Control: | Prot+Permit | | | Protected | | | Protected | | | Protected | | | | | |
| Rights: | Include | | | Include | | | Include | | | Include | | | | | |
| Min. Green: | 0 | 0 | 0 | 0 | 0 | 0 | 0 | 0 | 0 | 0 | 0 | 0 | | | |
| Lanes: | 1 | 0 | 2 | 0 | 1 | 2 | 0 | 2 | 0 | 1 | 2 | 0 | 2 | 0 | 1 |

Volume Module:

| | | | | | | | | | | | | |
|--------------|------|------|------|------|------|------|------|------|------|------|------|------|
| Base Vol: | 0 | 0 | 0 | 0 | 0 | 0 | 0 | 0 | 0 | 0 | 0 | 0 |
| Growth Adj: | 1.00 | 1.00 | 1.00 | 1.00 | 1.00 | 1.00 | 1.00 | 1.00 | 1.00 | 1.00 | 1.00 | 1.00 |
| Initial Bse: | 0 | 0 | 0 | 0 | 0 | 0 | 0 | 0 | 0 | 0 | 0 | 0 |
| Added Vol: | 197 | 172 | 371 | 422 | 477 | 633 | 388 | 665 | 275 | 748 | 940 | 167 |
| PasserByVol: | 0 | 0 | 0 | 0 | 0 | 0 | 0 | 0 | 0 | 0 | 0 | 0 |
| Initial Fut: | 197 | 172 | 371 | 422 | 477 | 633 | 388 | 665 | 275 | 748 | 940 | 167 |
| User Adj: | 1.00 | 1.00 | 1.00 | 1.00 | 1.00 | 1.00 | 1.00 | 1.00 | 1.00 | 1.00 | 1.00 | 1.00 |
| PHF Adj: | 1.00 | 1.00 | 1.00 | 1.00 | 1.00 | 1.00 | 1.00 | 1.00 | 1.00 | 1.00 | 1.00 | 1.00 |
| PHF Volume: | 197 | 172 | 371 | 422 | 477 | 633 | 388 | 665 | 275 | 748 | 940 | 167 |
| Reduct Vol: | 0 | 0 | 0 | 0 | 0 | 0 | 0 | 0 | 0 | 0 | 0 | 0 |
| Reduced Vol: | 197 | 172 | 371 | 422 | 477 | 633 | 388 | 665 | 275 | 748 | 940 | 167 |
| PCE Adj: | 1.00 | 1.00 | 1.00 | 1.00 | 1.00 | 1.00 | 1.00 | 1.00 | 1.00 | 1.00 | 1.00 | 1.00 |
| MLF Adj: | 1.00 | 1.00 | 1.00 | 1.00 | 1.00 | 1.00 | 1.00 | 1.00 | 1.00 | 1.00 | 1.00 | 1.00 |
| Final Vol.: | 197 | 172 | 371 | 422 | 477 | 633 | 388 | 665 | 275 | 748 | 940 | 167 |

Saturation Flow Module:

| | | | | | | | | | | | | |
|-------------|------|------|------|------|------|------|------|------|------|------|------|------|
| Sat/Lane: | 1900 | 1900 | 1900 | 1900 | 1900 | 1900 | 1900 | 1900 | 1900 | 1900 | 1900 | 1900 |
| Adjustment: | 0.95 | 0.95 | 0.85 | 0.92 | 0.95 | 0.85 | 0.92 | 0.95 | 0.85 | 0.92 | 0.95 | 0.85 |
| Lanes: | 1.00 | 2.00 | 1.00 | 2.00 | 2.00 | 1.00 | 2.00 | 2.00 | 1.00 | 2.00 | 2.00 | 1.00 |
| Final Sat.: | 1805 | 3610 | 1615 | 3502 | 3610 | 1615 | 3502 | 3610 | 1615 | 3502 | 3610 | 1615 |

Capacity Analysis Module:

| | | | | | | | | | | | | |
|---------------|------|------|------|------|------|------|------|------|------|------|------|------|
| Vol/Sat: | 0.11 | 0.05 | 0.23 | 0.12 | 0.13 | 0.39 | 0.11 | 0.18 | 0.17 | 0.21 | 0.26 | 0.10 |
| Crit Moves: | **** | | | **** | | | **** | | | **** | | |
| Green/Cycle: | 0.56 | 0.37 | 0.37 | 0.19 | 0.44 | 0.44 | 0.13 | 0.20 | 0.20 | 0.24 | 0.31 | 0.31 |
| Volume/Cap: | 0.37 | 0.13 | 0.63 | 0.63 | 0.30 | 0.90 | 0.84 | 0.90 | 0.83 | 0.90 | 0.84 | 0.33 |
| Uniform Del: | 6.9 | 12.7 | 15.7 | 22.3 | 11.0 | 15.7 | 25.4 | 23.2 | 22.9 | 22.2 | 19.3 | 15.9 |
| IncrementDel: | 0.4 | 0.0 | 2.2 | 1.9 | 0.1 | 14.5 | 12.8 | 13.9 | 16.1 | 12.6 | 5.7 | 0.4 |
| InitQueueDel: | 0.0 | 0.0 | 0.0 | 0.0 | 0.0 | 0.0 | 0.0 | 0.0 | 0.0 | 0.0 | 0.0 | 0.0 |
| Delay Adj: | 1.00 | 1.00 | 1.00 | 1.00 | 1.00 | 1.00 | 1.00 | 1.00 | 1.00 | 1.00 | 1.00 | 1.00 |
| Delay/Veh: | 7.4 | 12.7 | 17.8 | 24.2 | 11.1 | 30.2 | 38.2 | 37.1 | 39.0 | 34.8 | 25.0 | 16.3 |
| User DelAdj: | 1.00 | 1.00 | 1.00 | 1.00 | 1.00 | 1.00 | 1.00 | 1.00 | 1.00 | 1.00 | 1.00 | 1.00 |
| AdjDel/Veh: | 7.4 | 12.7 | 17.8 | 24.2 | 11.1 | 30.2 | 38.2 | 37.1 | 39.0 | 34.8 | 25.0 | 16.3 |
| LOS by Move: | A | B | B | C | B | C | D | D | D | C | C | B |
| HCM2kAvgQ: | 2 | 1 | 7 | 5 | 3 | 15 | 6 | 10 | 8 | 11 | 12 | 3 |

```

-----
Level Of Service Computation Report
2000 HCM Operations Method (Future Volume Alternative)
*****
Intersection #6 Ranch Lane & Business Park Drive
*****
Cycle (sec):          60          Critical Vol./Cap.(X):          0.748
Loss Time (sec):      0 (Y+R=4.0 sec)  Average Delay (sec/veh):          11.8
Optimal Cycle: OPTIMIZED          Level Of Service:          B
*****
Street Name:          Business Park Drive          Ranch Lane
Approach:             North Bound          South Bound          East Bound          West Bound
Movement:             L - T - R          L - T - R          L - T - R          L - T - R
-----|-----|-----|-----|
Control:              Permitted          Permitted          Permitted          Permitted
Rights:               Include            Include            Include            Include
Min. Green:           0   0   0           0   0   0           0   0   0           0   0   0
Lanes:                1  0  1  0  1       1  0  1  0  1       1  0  1  0  1       1  0  1  0  1
-----|-----|-----|-----|
Volume Module:
Base Vol:             0   0   0           0   0   0           0   0   0           0   0   0
Growth Adj:           1.00 1.00 1.00 1.00 1.00 1.00 1.00 1.00 1.00 1.00 1.00 1.00
Initial Bse:          0   0   0           0   0   0           0   0   0           0   0   0
Added Vol:            53 131 61 454 220 401 205 342 84 102 478 303
PasserByVol:         0   0   0           0   0   0           0   0   0           0   0   0
Initial Fut:          53 131 61 454 220 401 205 342 84 102 478 303
User Adj:             1.00 1.00 1.00 1.00 1.00 1.00 1.00 1.00 1.00 1.00 1.00 1.00
PHF Adj:              1.00 1.00 1.00 1.00 1.00 1.00 1.00 1.00 1.00 1.00 1.00 1.00
PHF Volume:           53 131 61 454 220 401 205 342 84 102 478 303
Reduct Vol:           0   0   0           0   0   0           0   0   0           0   0   0
Reduced Vol:          53 131 61 454 220 401 205 342 84 102 478 303
PCE Adj:              1.00 1.00 1.00 1.00 1.00 1.00 1.00 1.00 1.00 1.00 1.00 1.00
MLF Adj:              1.00 1.00 1.00 1.00 1.00 1.00 1.00 1.00 1.00 1.00 1.00 1.00
Final Vol.:           53 131 61 454 220 401 205 342 84 102 478 303
-----|-----|-----|-----|
Saturation Flow Module:
Sat/Lane:             1900 1900 1900 1900 1900 1900 1900 1900 1900 1900 1900 1900
Adjustment:           0.53 1.00 0.85 0.62 1.00 0.85 0.30 1.00 0.85 0.41 1.00 0.85
Lanes:                1.00 1.00 1.00 1.00 1.00 1.00 1.00 1.00 1.00 1.00 1.00 1.00
Final Sat.:           1015 1900 1615 1176 1900 1615 566 1900 1615 785 1900 1615
-----|-----|-----|-----|
Capacity Analysis Module:
Vol/Sat:              0.05 0.07 0.04 0.39 0.12 0.25 0.36 0.18 0.05 0.13 0.25 0.19
Crit Moves:          *****
Green/Cycle:          0.52 0.52 0.52 0.52 0.52 0.52 0.48 0.48 0.48 0.48 0.48 0.48
Volume/Cap:           0.10 0.13 0.07 0.75 0.22 0.48 0.75 0.37 0.11 0.27 0.52 0.39
Uniform Del:           7.4 7.5 7.3 11.4 7.9 9.3 12.5 9.7 8.4 9.2 10.7 9.8
IncrmntDel:           0.1 0.1 0.0 5.1 0.1 0.4 10.8 0.3 0.1 0.4 0.5 0.3
InitQueuDel:          0.0 0.0 0.0 0.0 0.0 0.0 0.0 0.0 0.0 0.0 0.0 0.0
Delay Adj:            1.00 1.00 1.00 1.00 1.00 1.00 1.00 1.00 1.00 1.00 1.00 1.00
Delay/Veh:            7.5 7.6 7.3 16.6 8.1 9.8 23.3 10.0 8.5 9.6 11.2 10.2
User DelAdj:          1.00 1.00 1.00 1.00 1.00 1.00 1.00 1.00 1.00 1.00 1.00 1.00
AdjDel/Veh:           7.5 7.6 7.3 16.6 8.1 9.8 23.3 10.0 8.5 9.6 11.2 10.2
LOS by Move:          A   A   A   B   A   A   C   A   A   A   B   B
HCM2kAvgQ:            1   1   1   9   2   5   5   4   1   1   7   4
*****

```

November 2, 2009

Nathan D. Shipp, Partner
DAI
1099 W. South Jordan Parkway
South Jordan, UT 84095

Subject: SR-73 Roadway Capacity for Pole Canyon Development

Nate:

Per your request, I have evaluated how much development could occur in the Pole Canyon Project using only SR-73 for access before Pole Canyon Boulevard or another roadway needs to be extended from the project east to Town Center. A two lane rural highway like SR-73 has a capacity of 1,000 vehicles per hour per lane, and operates well until the traffic volumes reach 90 percent of the capacity (900 vehicles/hour). Peak hour traffic counts completed on SR-73 south of Cedar Fort last year indicate that during the AM peak hour there were 82 vehicles traveling northbound and 45 southbound. During the PM peak hour there were 163 vehicles northbound and 121 vehicles traveling southbound. The difference between the existing traffic volume and 900 is the amount of additional traffic that can be accommodated on SR-73 before additionally roadway improvements would be required.

Cedar Fort and Fairfield both have policies that discourage significant growth, however to account for future traffic growth on SR-73 not associated with the Pole Canyon Project we have increased the existing traffic volumes by 50 percent. We propose that standard Institute of Transportation Engineers (ITE) trip generation rates be used to forecast traffic from the Pole Canyon Development and determine how much development can be constructed before additional off-site roadway improvements are required. Each direction of travel on SR-73 and both the AM and PM peak hours were analyzed, but because the PM peak hour traffic volumes and trip generation rates are higher this is the critical time period.

Based on trip generation rates in the Institute of Transportation Engineers (ITE) *Trip Generation Manual, 7th Edition* (Land Use Code 210) a single family home generates 0.75 trips during the AM peak hour (0.19 inbound and 0.56 outbound) and 1.01 trips during the PM peak hour (0.64 inbound and 0.37 outbound). Other types of residential development generate fewer trips per unit. The industrial uses planned in the Pole Canyon Development (Land Use Code 130) are expected to generate 8.55 trips per acre of development during the AM peak hour (7.10 inbound and 1.45 outbound) and 8.84 trips during the PM peak hour (1.86 inbound and 6.98 outbound). It is important to note that the peak travel direction is opposite for these two land uses, with most residential traffic leaving in the morning and returning in the evening and most industrial traffic arriving in the morning and leaving in the evening.

Table 1 presents our calculation of how many single family homes could be constructed in the Pole Canyon Development before additional off-site roadway improvements would be required. Table 2 presents a similar calculation assuming all industrial development in the project. The

smallest number in the final column in each table (which is in bold type) represents the maximum amount of development that could be constructed before additional off-site roadway improvements would be required.

Table 1 SR-73 Surplus Capacity for Residential Development (PM Peak Hour)

| Direction | Existing Volume (A) | Existing Capacity Increased 50% (B) | Surplus Capacity 900 – B (C) | Single Family Home Trips/Unit (D) | Number of Homes that could be built without road improvements C/D |
|------------|---------------------|-------------------------------------|------------------------------|-----------------------------------|-------------------------------------------------------------------|
| Northbound | 163 | 245 | 655 | 0.37 | 1,770 |
| Southbound | 121 | 182 | 718 | 0.64 | 1,121* |

* The maximum number of single family homes that could be built in Pole Canyon before off-site roadway improvements are constructed.

Table 2 SR-73 Surplus Capacity for Industrial Development (PM Peak Hour)

| Direction | Existing Volume (A) | Existing Capacity Increased 50% (B) | Surplus Capacity 900 – B (C) | Industrial Park Trips/Acre (D) | Number of acres that could be built without road improvements C/D |
|------------|---------------------|-------------------------------------|------------------------------|--------------------------------|-------------------------------------------------------------------|
| Northbound | 163 | 245 | 655 | 6.98 | 94* |
| Southbound | 121 | 182 | 718 | 1.86 | 386 |

* The maximum number of acres of industrial development that could be built in Pole Canyon before off-site roadway improvements are constructed.

A mix of industrial and residential development is anticipated in the first few phases of the Pole Canyon Project. Following the same procedure described above 800 single-family homes and 51 acres of industrial uses could be constructed before additional off-site roadway improvements are required. Slightly more residential units could be constructed if some townhouses or apartments are built because they have lower trip generation rates. This traffic analysis is a conservative because it assumes that there are no internal project trips and that all of Pole Canyon traffic will be oriented to the north on SR-73.

We recommend that the procedure outlined in this letter be used to calculate how much development can be constructed in the Pole Canyon Project before off-site transportation improvements are constructed. Please contact me at (801) 906-9218 if you have any questions or require additional traffic support.

Sincerely,



Jay L. Nelson, PE, PTOE
Senior Transportation Engineer

Exhibit 8 – Open Space and/or Trails

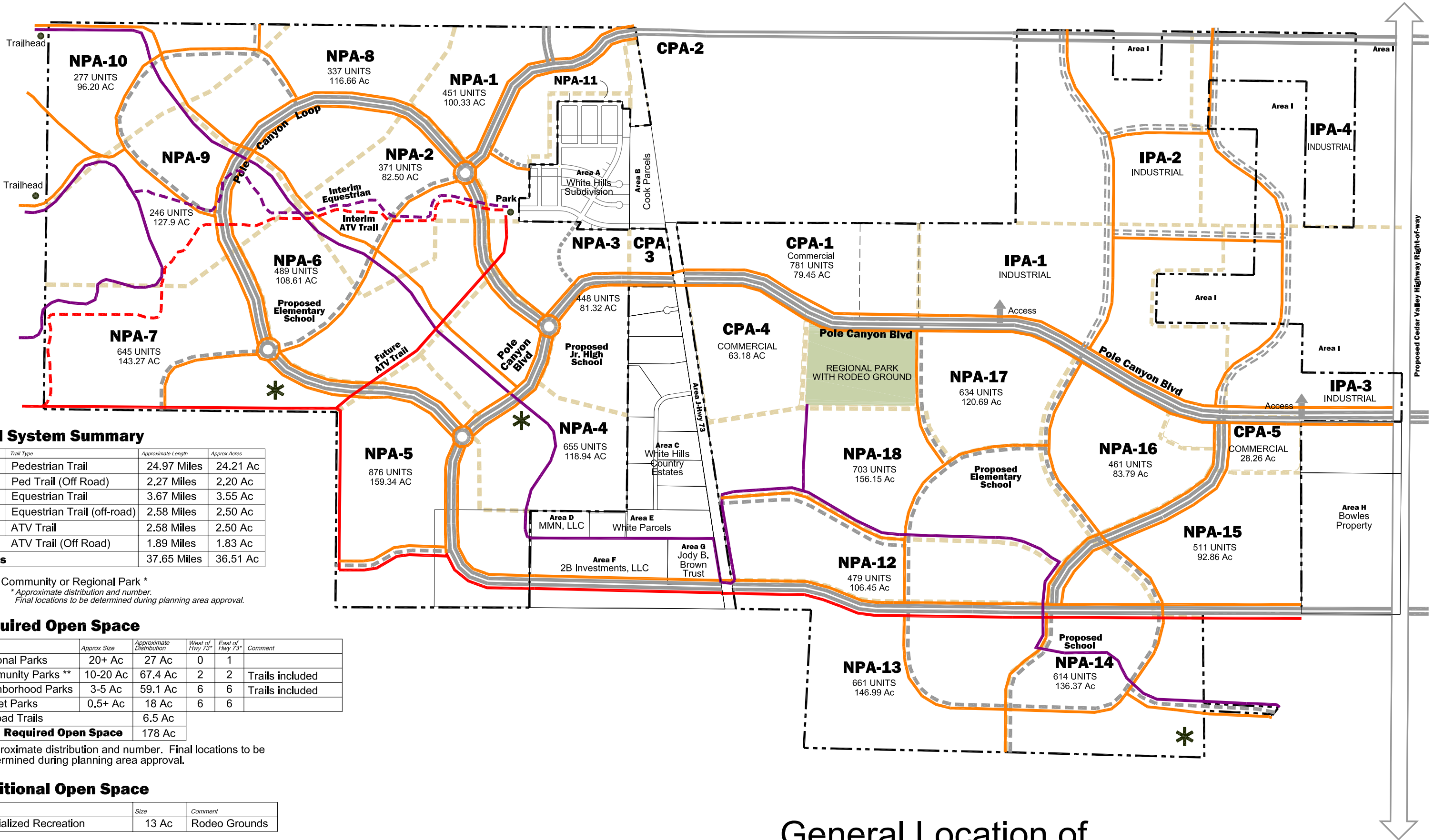

Trail System Summary

| Legend | Trail Type | Approximate Length | Approx Acres |
|---------------|-----------------------------|--------------------|-----------------|
| | Pedestrian Trail | 24.97 Miles | 24.21 Ac |
| | Ped Trail (Off Road) | 2.27 Miles | 2.20 Ac |
| | Equestrian Trail | 3.67 Miles | 3.55 Ac |
| | Equestrian Trail (off-road) | 2.58 Miles | 2.50 Ac |
| | ATV Trail | 2.58 Miles | 2.50 Ac |
| | ATV Trail (Off Road) | 1.89 Miles | 1.83 Ac |
| Totals | | 37.65 Miles | 36.51 Ac |

Community or Regional Park *
 * Approximate distribution and number.
 Final locations to be determined during planning area approval.

Required Open Space

| Type | Approx Size | Approximate Distribution | West of Hwy 73* | East of Hwy 73* | Comment |
|----------------------------------|-------------|--------------------------|-----------------|-----------------|-----------------|
| Regional Parks | 20+ Ac | 27 Ac | 0 | 1 | |
| Community Parks ** | 10-20 Ac | 67.4 Ac | 2 | 2 | Trails included |
| Neighborhood Parks | 3-5 Ac | 59.1 Ac | 6 | 6 | Trails included |
| Pocket Parks | 0.5+ Ac | 18 Ac | 6 | 6 | |
| Off-road Trails | | 6.5 Ac | | | |
| Total Required Open Space | | 178 Ac | | | |

* Approximate distribution and number. Final locations to be determined during planning area approval.

Additional Open Space

| Type | Size | Comment |
|------------------------|-------|---------------|
| Specialized Recreation | 13 Ac | Rodeo Grounds |

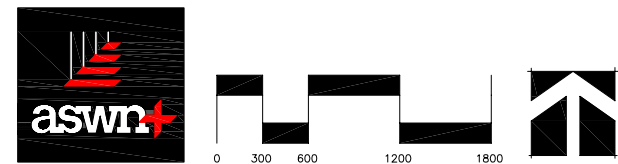

Planning Area Boundary
Planned Interim Trails *
 Interim Equestrian Trail
 Interim ATV Trail

General Location of Open Space & Trails

Exhibit 8



Proposed Cedar Valley Highway Right-of-way

Exhibit 9 – Local District Maps

BOUNDARY DESCRIPTIONS

LAND LYING IN SECTION 16, THE SOUTH 1/2 SECTION 17, SECTION 18, THE NORTH 1/2 SECTION 19, THE NW 1/4, THE NE 1/4, AND THE SE 1/4 SECTION 20, AND IN SECTION 21, TOWNSHIP 6 SOUTH, RANGE 2 WEST, SALT LAKE BASE AND MERIDIAN, AND IN THE EAST 1/2 OF SECTION 13, TOWNSHIP 6 SOUTH, RANGE 3 WEST, SALT LAKE BASE AND MERIDIAN, DESCRIBED AS FOLLOWS:

BEGINNING AT THE NORTHEAST CORNER OF SECTION 16, TOWNSHIP 6 SOUTH, RANGE 2 WEST, SALT LAKE BASE & MERIDIAN, AND RUNNING SOUTH 89°30'22" EAST, 81.03 FEET ALONG THE SECTION LINE TO THE WESTERLY RIGHT-OF-WAY LINE OF STATE ROUTE NO. 73; THENCE SOUTH 08°40'29" EAST, 175.00 FEET ALONG SAID RIGHT-OF-WAY LINE; THENCE LEAVING SAID RIGHT-OF-WAY LINE AND RUNNING ALONG THE BOUNDARY LINE OF THE WILLIAMS H. AND TERESA WILSON PROPERTY (DEVELOPMENT AGREEMENT) IN THE FOLLOWING TWO COURSES: SOUTH 81°19'31" WEST, 220.00 FEET; THENCE SOUTH 08°40'29" EAST, 731.70 FEET TO THE NORTH BOUNDARY LINE OF THE WHITE HILLS WATER CONSERVANCY PROPERTY; THENCE WEST 97.50 FEET ALONG SAID NORTH BOUNDARY LINE; THENCE NORTH 00°01'20" EAST, 21.15 FEET; THENCE NORTH 89°58'40" WEST, 1004.00 FEET; THENCE SOUTH 00°01'20" WEST, 870.00 FEET; THENCE NORTH 89°58'40" WEST, 276.00 FEET; THENCE SOUTH 00°01'20" WEST, 110.00 FEET TO THE WEST BOUNDARY LINE OF "WHITE HILLS SUBDIVISION PLAT B"; THENCE SOUTH 00°01'20" WEST, 163.52 FEET ALONG SAID WEST BOUNDARY LINE TO THE WEST BOUNDARY LINE OF "WHITE HILLS SUBDIVISION PLAT A AMENDED"; THENCE ALONG THE WEST AND SOUTH BOUNDARY OF SAID SUBDIVISION IN THE FOLLOWING NINE COURSES: SOUTH 00°01'20" WEST, 300.00 FEET; THENCE NORTH 89°58'40" W, 143.00 FEET; THENCE SOUTH 00°01'20" WEST, 321.15 FEET; THENCE SOUTH 89°28'47" EAST, 851.85 FEET; THENCE SOUTH 31°31'20" WEST, 117.29 FEET; THENCE SOUTH 89°28'47" EAST, 200.45 FEET; THENCE NORTH 00°01'20" EAST, 66.13 FEET TO A POINT ON THE ARC OF A 742.11 FOOT RADIUS CURVE TO THE LEFT, THE BEARING TO HADIUS POINT BEING NORTH 21°33'06" EAST; THENCE EASTERLY 273.40 FEET ALONG THE ARC OF SAID CURVE THROUGH A CENTRAL ANGLE OF 21°08'30" TO THE POINT OF TANGENCY; THENCE SOUTH 89°33'23" EAST, 409.98 FEET ALONG SAID SUBDIVISION BOUNDARY LINE AND THE PROLONGATION THEREFROM TO THE EASTERLY RIGHT-OF-WAY LINE OF "STATE ROUTE NO. 73"; THENCE NORTH 08°40'29" WEST, 87.54 FEET ALONG SAID RIGHT-OF-WAY LINE TO A POINT ON THE EAST-WEST CENTER SECTION LINE OF SECTION 17, TOWNSHIP 6 SOUTH, RANGE 2 WEST, SALT LAKE BASE & MERIDIAN; THENCE SOUTH 89°51'20" EAST, 2021.71 FEET ALONG SAID CENTER SECTION LINE TO THE CENTER 1/4 CORNER OF SAID SECTION 17; THENCE SOUTH 89°31'20" EAST, 512.21 FEET ALONG THE CENTER SECTION LINE TO THE WEST BOUNDARY LINE OF THE "WHITE HILLS SPECIAL SERVICE DISTRICT" PROPERTY RECORDED AS ENTRY # 040239-1986, IN THE OFFICE OF THE RECORDER FOR UTAH COUNTY, STATE OF UTAH; THENCE ALONG THE BOUNDARY LINE OF SAID PROPERTY IN THE FOLLOWING THREE COURSES: SOUTH 00°23'34" WEST, 1336.39 FEET TO THE SOUTH 1/16 LINE; THENCE SOUTH 89°40'18" EAST, 811.68 FEET ALONG THE SOUTH 1/16 LINE; THENCE NORTH 00°30'03" EAST, 1339.00 FEET TO THE CENTER SECTION LINE; THENCE SOUTH 89°51'20" EAST, 1326.43 FEET ALONG THE CENTER SECTION LINE TO THE EAST 1/4 CORNER OF SAID SECTION 17; THENCE NORTH 00°23'57" EAST, 2668.89 FEET ALONG THE SECTION LINE TO THE NORTHWEST CORNER OF SECTION 16, TOWNSHIP 6 SOUTH, RANGE 2 WEST, SALT LAKE BASE & MERIDIAN; THENCE SOUTH 89°22'57" EAST, 1433.51 FEET ALONG THE SECTION LINE TO THE WEST BOUNDARY OF THE "HANELI" PROPERTY, SERIAL NO. 58,048,007; THENCE ALONG SAID BOUNDARY IN THE FOLLOWING THREE COURSES: SOUTH 00°58'27" WEST, 667.89 FEET; THENCE SOUTH 89°22'01" EAST, 883.70 FEET; THENCE NORTH 01°11'12" EAST, 687.78 FEET TO THE SECTION LINE; THENCE SOUTH 89°22'57" EAST, 866.78 FEET TO THE NORTH 1/4 CORNER OF SAID SECTION 16; THENCE SOUTH 89°23'28" EAST, 2000.34 FEET TO THE NORTHEAST CORNER OF THE NORTHEAST 1/4 OF THE NORTHEAST 1/4 OF THE NORTHEAST 1/4 OF SAID SECTION 16; THENCE SOUTH 00°37'53" WEST, 2874.28 FEET TO THE SOUTHEAST CORNER OF THE SOUTHWEST 1/4 OF THE SOUTHEAST 1/4 OF THE NORTHEAST 1/4 OF SAID SECTION 16; THENCE NORTH 89°10'10" WEST, 818.66 FEET ALONG THE CENTER SECTION LINE TO THE SOUTHWEST CORNER OF THE SOUTHWEST 1/4 OF THE NORTHEAST 1/4 OF THE NORTHEAST 1/4 OF SAID SECTION 16; THENCE NORTH 00°54'13" EAST, 1005.11 FEET TO THE SOUTHWEST CORNER OF THE NORTHEAST 1/4 OF THE NORTHEAST 1/4 OF SAID SECTION 16; THENCE NORTH 89°22'21" WEST, 1340.09 FEET TO THE NORTHWEST CORNER OF THE SOUTHWEST 1/4 OF THE NORTHEAST 1/4 OF THE NORTHEAST 1/4 OF SAID SECTION 16; THENCE SOUTH 01°26'55" WEST, 688.01 FEET TO THE SOUTHWEST CORNER OF THE SOUTHWEST 1/4 OF THE NORTHEAST 1/4 OF THE NORTHEAST 1/4 OF SAID SECTION 16; THENCE SOUTH 89°21'18" EAST, 673.20 FEET TO THE SOUTHWEST CORNER OF THE SOUTHWEST 1/4 OF THE NORTHEAST 1/4 OF THE NORTHEAST 1/4 OF SAID SECTION 16; THENCE SOUTH 01°11'37" WEST, 670.14 FEET TO THE SOUTHEAST CORNER OF THE NORTHEAST 1/4 OF THE NORTHEAST 1/4 OF SAID SECTION 16; THENCE SOUTH 89°24'20" WEST, 682.85 FEET TO THE SOUTHWEST CORNER OF THE NORTHEAST 1/4 OF THE NORTHEAST 1/4 OF THE SOUTHWEST 1/4 OF SAID SECTION 16; THENCE NORTH 89°19'47" WEST, 651.45 FEET TO THE NORTHWEST CORNER OF THE SOUTHWEST 1/4 OF THE NORTHEAST 1/4 OF THE SOUTHWEST 1/4 OF SAID SECTION 16; THENCE SOUTH 01°11'10" WEST, 671.28 FEET TO THE SOUTHWEST CORNER OF THE SOUTHWEST 1/4 OF THE NORTHEAST 1/4 OF THE SOUTHWEST 1/4 OF SAID SECTION 16; THENCE SOUTH 89°20'26" EAST, 648.38 FEET TO THE SOUTHWEST CORNER OF THE SOUTHWEST 1/4 OF THE NORTHEAST 1/4 OF THE SOUTHWEST 1/4 OF SAID SECTION 16; THENCE SOUTH 89°22'27" EAST, 1371.10 FEET TO THE NORTHEAST CORNER OF THE NORTHEAST 1/4 OF THE SOUTHWEST 1/4 OF THE SOUTHWEST 1/4 OF SAID SECTION 16; THENCE SOUTH 00°08'10" WEST, 669.10 FEET TO THE SOUTHWEST CORNER OF THE NORTHEAST 1/4 OF THE SOUTHWEST 1/4 OF THE SOUTHWEST 1/4 OF SAID SECTION 16; THENCE SOUTH 89°34'32" EAST, 1377.10 FEET TO THE NORTHEAST CORNER OF THE SOUTHWEST 1/4 OF THE SOUTHWEST 1/4 OF THE SOUTHWEST 1/4 OF SAID SECTION 16; THENCE SOUTH 00°25'25" WEST, 667.04 FEET ALONG THE SECTION LINE TO THE SOUTHWEST CORNER OF SAID SECTION 16; THENCE NORTH 89°39'34" WEST, 1383.11 FEET ALONG THE SECTION LINE TO THE NORTHEAST CORNER OF THE NORTHEAST 1/4 OF THE NORTHEAST 1/4 OF SECTION 21, TOWNSHIP 6 SOUTH, RANGE 2 WEST, SALT LAKE BASE & MERIDIAN; THENCE SOUTH 00°07'20" EAST, 2656.89 FEET ALONG THE EAST 1/16 LINE TO THE SOUTHWEST CORNER OF THE SOUTHWEST 1/4 OF THE NORTHEAST 1/4 OF SAID SECTION 21; THENCE NORTH 89°39'48" WEST, 1358.67 FEET ALONG THE EAST-WEST CENTER SECTION LINE TO THE CENTER 1/4 OF SAID SECTION 21; THENCE SOUTH 00°37'47" EAST, 1243.03 FEET ALONG THE CENTER SECTION LINE; THENCE SOUTH 87°12'10" EAST, 1001.36 FEET TO THE WEST BOUNDARY LINE OF THE LEHI TO FAIRFIELD ROAD; THENCE SOUTH 51°20'10" EAST, 28.00 FEET TO THE CENTERLINE OF SAID ROAD; THENCE SOUTH 38°39'50" WEST, 123.17 FEET ALONG SAID CENTERLINE; THENCE NORTH 51°20'10" WEST, 28.00 FEET TO THE WEST BOUNDARY LINE OF SAID ROAD; THENCE NORTH 87°12'10" WEST, 823.22 FEET TO THE CENTER SECTION LINE; THENCE SOUTH 00°37'47" EAST, 643.56 FEET ALONG THE CENTER SECTION LINE TO THE NORTH BOUNDARY LINE OF 2800 NORTH STREET; THENCE LEAVING THE CENTER SECTION LINE AND RUNNING NORTH 89°30'22" WEST, 2684.40 FEET ALONG SAID NORTH BOUNDARY LINE TO THE WEST LINE OF THE SOUTHWEST 1/4 OF SAID SECTION 21, BEING THE EAST LINE OF THE SOUTHWEST 1/4 OF SECTION 20, TOWNSHIP 6 SOUTH, RANGE 2 WEST, SALT LAKE BASE & MERIDIAN; THENCE NORTH 89°48'05" WEST, 2853.85 FEET TO THE NORTH-SOUTH CENTER SECTION LINE OF SAID SECTION 20; THENCE NORTH 02°06'34" EAST, 1905.75 FEET ALONG THE SECTION LINE TO THE CENTER 1/4 CORNER OF SAID SECTION 20; THENCE NORTH 89°21'12" WEST, 2549.27 FEET ALONG THE EAST-WEST CENTER SECTION LINE TO THE EAST 1/4 CORNER OF SAID SECTION 20; THENCE NORTH 89°54'53" WEST, 4000.34 FEET ALONG THE EAST-WEST CENTER SECTION LINE OF SECTION 19, TOWNSHIP 6 SOUTH, RANGE 2 WEST, SALT LAKE BASE & MERIDIAN TO THE SOUTHWEST CORNER OF THE SOUTHWEST 1/4 OF THE NORTHEAST 1/4 OF SAID SECTION 19; THENCE NORTH 00°22'32" EAST, 2891.68 FEET TO THE NORTHWEST CORNER OF THE NORTHEAST 1/4 OF THE NORTHEAST 1/4 OF SAID SECTION 19; THENCE NORTH 89°30'26" WEST, 1334.74 FEET ALONG THE SECTION LINE TO THE NORTHWEST CORNER OF SAID SECTION 19; THENCE NORTH 89°25'32" WEST, 2701.52 FEET ALONG THE SOUTH LINE OF SECTION 13, TOWNSHIP 6 SOUTH, RANGE 3 WEST, SALT LAKE BASE & MERIDIAN TO THE SOUTH 1/4 CORNER OF SAID SECTION 13; THENCE NORTH 00°44'00" EAST, 5331.71 FEET ALONG THE NORTH-SOUTH CENTER SECTION LINE TO THE NORTH 1/4 CORNER OF SAID SECTION 13; THENCE SOUTH 89°28'51" EAST, 2683.99 FEET ALONG THE SECTION LINE TO THE NORTHEAST CORNER OF SAID SECTION 13; THENCE SOUTH 89°25'11" EAST, 2655.67 FEET ALONG THE NORTH LINE OF SECTION 18, TOWNSHIP 6 SOUTH, RANGE 2 WEST, SALT LAKE BASE & MERIDIAN TO THE NORTH 1/4 CORNER OF SAID SECTION 18; THENCE SOUTH 89°32'03" EAST, 2670.91 FEET ALONG THE SECTION LINE TO THE POINT OF BEGINNING, CONTAINING 2,746.51 ACRES MORE OR LESS.

LESS AND EXCEPTING FROM THE ABOVE DESCRIBED LAND, THE FOLLOWING TEN PARCELS:

PARCEL 1:
A PARCEL OF LAND LYING IN THE SOUTHWEST 1/4 OF SECTION 17, TOWNSHIP 6 SOUTH, RANGE 2 WEST, SALT LAKE BASE & MERIDIAN, DESCRIBED AS FOLLOWS:

BEGINNING AT A POINT SOUTH 00°36'11" WEST, 1204.17 FEET ALONG THE SECTION LINE, AND WEST, 1007.98 FEET FROM THE CENTER 1/4 CORNER OF SECTION 17, TOWNSHIP 6 SOUTH, RANGE 2 WEST, SALT LAKE BASE & MERIDIAN; THENCE SOUTH 08°40'29" EAST, 445.60 FEET; THENCE NORTH 81°04'31" EAST, 103.41 FEET; THENCE SOUTH 08°40'29" EAST, 86.58 FEET; THENCE SOUTH 81°04'31" WEST, 237.30 FEET TO THE EASTERLY RIGHT-OF-WAY LINE OF "STATE ROUTE NO. 73"; THENCE NORTH 08°40'29" WEST, 5321.8 FEET ALONG SAID RIGHT-OF-WAY LINE; THENCE LEAVING SAID RIGHT-OF-WAY LINE, RUNNING NORTH 81°04'31" EAST, 133.89 FEET TO THE POINT OF BEGINNING, CONTAINING 1.84 ACRES MORE OR LESS.

EXHIBIT "A"

THAT PART OF THE NORTHEAST 1/4 OF SECTION 16, TOWNSHIP 6 SOUTH, RANGE 2 WEST, SALT LAKE BASE AND MERIDIAN, DESCRIBED AS FOLLOWS:
BEGINNING AT A POINT SOUTH 89°23'28" EAST, 75.88 FEET ALONG THE SECTION LINE FROM THE NORTH 1/4 CORNER OF SECTION 16, TOWNSHIP 6 SOUTH, RANGE 2 WEST, SALT LAKE BASE AND MERIDIAN; THENCE SOUTH 89°23'28" EAST, 200.00 FEET ALONG THE SECTION LINE; THENCE SOUTH 00°25'30" WEST, 187.32 FEET; THENCE NORTH 89°23'28" WEST, 200.00 FEET; THENCE NORTH 00°25'30" EAST, 187.32 FEET TO THE POINT OF BEGINNING.

EXHIBIT "B"

LAND LYING IN THE SOUTHWEST 1/4 OF SECTION 18, AND IN THE NORTHWEST 1/4 OF SECTION 21, TOWNSHIP 6 SOUTH, RANGE 2 WEST, SALT LAKE BASE AND MERIDIAN, DESCRIBED AS FOLLOWS:
BEGINNING AT A POINT SOUTH 89°21'43" EAST, 988.23 FEET ALONG THE SECTION LINE FROM THE SOUTHWEST CORNER OF SECTION 16, TOWNSHIP 6 SOUTH, RANGE 2 WEST, SALT LAKE BASE AND MERIDIAN; THENCE NORTH 00°37'31" EAST, 82.06 FEET; THENCE SOUTH 89°22'57" EAST, 200.00 FEET; THENCE SOUTH 00°37'31" WEST, 200.00 FEET; THENCE NORTH 89°22'57" WEST, 200.00 FEET; THENCE NORTH 00°37'31" EAST, 117.04 FEET TO THE POINT OF BEGINNING.

EXHIBIT "C"

THAT PART OF THE NORTHWEST 1/4 OF SECTION 21, TOWNSHIP 6 SOUTH, RANGE 2 WEST, SALT LAKE BASE AND MERIDIAN, DESCRIBED AS FOLLOWS:
BEGINNING AT A POINT SOUTH 00°38'49" WEST, 1200.10 FEET ALONG THE SECTION LINE, AND EAST, 1011.49 FEET FROM THE NORTHWEST CORNER OF SECTION 21, TOWNSHIP 6 SOUTH, RANGE 2 WEST, SALT LAKE BASE AND MERIDIAN; THENCE SOUTH 89°22'57" EAST, 200.00 FEET; THENCE SOUTH 00°37'31" EAST, 200.00 FEET; THENCE NORTH 89°22'57" WEST, 200.00 FEET; THENCE NORTH 00°37'31" EAST, 200.00 FEET TO THE POINT OF BEGINNING.

EXHIBIT "D"

LAND LYING IN THE SOUTHWEST 1/4, AND IN THE SOUTHEAST 1/4 OF SECTION 17, TOWNSHIP 6 SOUTH, RANGE 2 WEST, SALT LAKE BASE AND MERIDIAN, DESCRIBED AS FOLLOWS:
BEGINNING AT A POINT NORTH 00°36'11" EAST, 542.32 FEET ALONG THE SECTION LINE FROM THE NORTH 1/4 CORNER OF SECTION 17, TOWNSHIP 6 SOUTH, RANGE 2 WEST, SALT LAKE BASE AND MERIDIAN; THENCE NORTH 89°30'09" WEST, 62.90 FEET; THENCE NORTH 00°35'13" EAST, 200.00 FEET; THENCE SOUTH 89°30'09" EAST, 200.00 FEET; THENCE SOUTH 00°35'13" WEST, 200.00 FEET; THENCE NORTH 89°30'09" WEST, 137.10 FEET TO THE POINT OF BEGINNING.

EXHIBIT "E"

LAND LYING IN THE SOUTHWEST 1/4, AND IN THE SOUTHEAST 1/4 OF SECTION 17, TOWNSHIP 6 SOUTH, RANGE 2 WEST, SALT LAKE BASE AND MERIDIAN, DESCRIBED AS FOLLOWS:
BEGINNING AT A POINT NORTH 00°36'11" EAST, 518.68 FEET ALONG THE SECTION LINE FROM THE SOUTH 1/4 CORNER OF SECTION 17, TOWNSHIP 6 SOUTH, RANGE 2 WEST, SALT LAKE BASE AND MERIDIAN; THENCE NORTH 89°30'09" WEST, 63.56 FEET; THENCE NORTH 00°35'13" EAST, 200.00 FEET; THENCE SOUTH 89°30'09" EAST, 200.00 FEET; THENCE SOUTH 00°35'13" WEST, 200.00 FEET; THENCE NORTH 89°30'09" WEST, 136.44 FEET TO THE POINT OF BEGINNING.

EXHIBIT "F"

THAT PART OF THE SOUTHWEST 1/4 OF SECTION 17, TOWNSHIP 6 SOUTH, RANGE 2 WEST, SALT LAKE BASE AND MERIDIAN, DESCRIBED AS FOLLOWS:
BEGINNING AT A POINT ON THE EASTERLY RIGHT-OF-WAY LINE OF STATE ROUTE NO. 73, SAID POINT BEING SOUTH 89°51'20" EAST, 828.08 FEET ALONG THE SECTION LINE, AND SOUTH, 1106.02 FEET FROM THE WEST 1/4 CORNER OF SECTION 17, TOWNSHIP 6 SOUTH, RANGE 2 WEST, SALT LAKE BASE AND MERIDIAN; THENCE NORTH 08°49'29" WEST, 32.00 FEET ALONG SAID RIGHT-OF-WAY LINE; SOUTH 89°32'22" EAST, 83.14 FEET; THENCE SOUTH 00°39'31" EAST, 32.01 FEET; THENCE NORTH 89°32'22" WEST, 83.23 FEET TO THE POINT OF BEGINNING.

EXHIBIT "G"

THAT PART OF THE SOUTHWEST 1/4 OF SECTION 17, TOWNSHIP 6 SOUTH, RANGE 2 WEST, SALT LAKE BASE AND MERIDIAN, DESCRIBED AS FOLLOWS:
BEGINNING AT A POINT ON THE EASTERLY RIGHT-OF-WAY LINE OF STATE ROUTE NO. 73, SAID POINT BEING SOUTH 89°51'20" EAST, 828.59 FEET ALONG THE SECTION LINE, AND SOUTH, 1051.20 FEET FROM THE WEST 1/4 CORNER OF SECTION 17, TOWNSHIP 6 SOUTH, RANGE 2 WEST, SALT LAKE BASE AND MERIDIAN; THENCE NORTH 08°49'29" WEST, 25.03 FEET ALONG SAID RIGHT-OF-WAY LINE; SOUTH 89°28'00" EAST, 19.71 FEET; THENCE SOUTH 11°55'17" EAST, 25.29 FEET; THENCE NORTH 89°28'00" WEST, 21.69 FEET TO THE POINT OF BEGINNING.

EXHIBIT "H"

THAT PART OF THE NORTHEAST 1/4 OF SECTION 18, TOWNSHIP 6 SOUTH, RANGE 2 WEST, SALT LAKE BASE AND MERIDIAN, DESCRIBED AS FOLLOWS:
BEGINNING AT A POINT SOUTH 00°30'14" WEST, 1039.97 FEET ALONG THE SECTION LINE, FROM THE NORTH 1/4 CORNER OF SECTION 18, TOWNSHIP 6 SOUTH, RANGE 2 WEST, SALT LAKE BASE AND MERIDIAN; THENCE NORTH 00°30'14" EAST, 208.00 FEET ALONG THE SECTION LINE; THENCE SOUTH 89°29'45" EAST, 210.00 FEET; THENCE SOUTH 00°30'14" WEST, 208.00 FEET; THENCE NORTH 89°29'45" WEST, 210.00 FEET TO THE POINT OF BEGINNING.

EXHIBIT "I"

LAND LYING IN THE NORTHEAST 1/4, AND IN THE SOUTHWEST 1/4 OF SECTION 13, TOWNSHIP 6 SOUTH, RANGE 3 WEST, SALT LAKE BASE AND MERIDIAN, DESCRIBED AS FOLLOWS:
BEGINNING AT A POINT NORTH 89°39'30" WEST, 1998.10 FEET ALONG THE SECTION LINE FROM THE EAST 1/4 CORNER OF SECTION 13, TOWNSHIP 6 SOUTH, RANGE 3 WEST, SALT LAKE BASE AND MERIDIAN; THENCE SOUTH, 178.23 FEET; THENCE WEST, 200.00 FEET; THENCE NORTH, 200.00 FEET; THENCE EAST, 200.00 FEET; THENCE SOUTH, 21.77 TO THE POINT OF BEGINNING.

Exhibit 9:

Local District

Pole Canyon Development

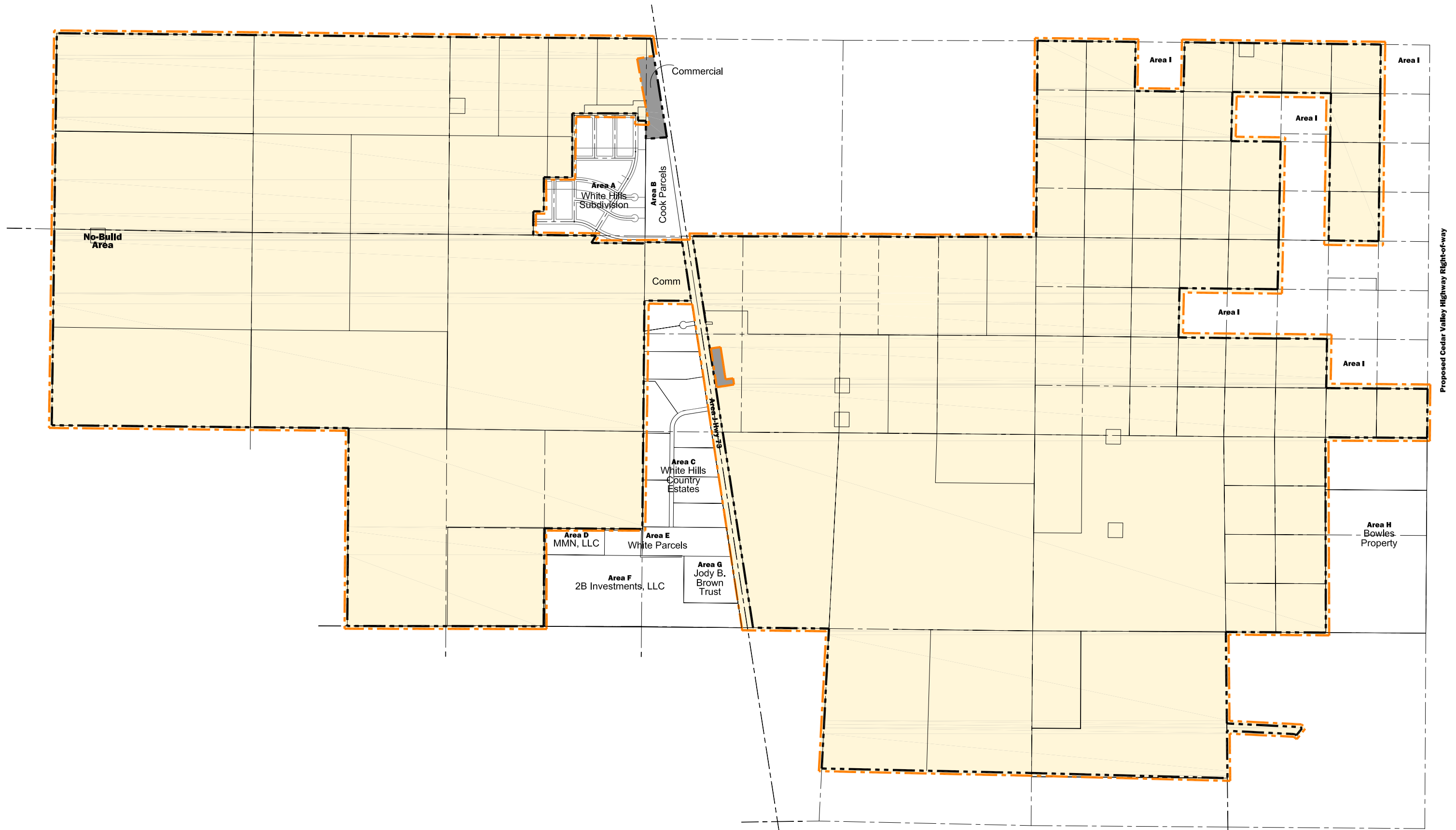

Pole Canyon Basic Local District Exhibit 9

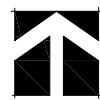
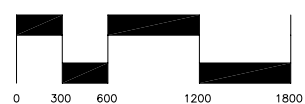

Local Area District Boundary - - - -



Exhibit 10 – WHSSD Agreement

FACILITIES AND SERVICE OBLIGATION TRANSFER AGREEMENT
 BETWEEN
 WHITE HILLS SPECIAL SERVICE DISTRICT
 -AND-
 EAGLE MOUNTAIN CITY

THIS AGREEMENT is made and entered into the 14th day of September, 2010, by and between White Hills Special Service District ("the District"), and Eagle Mountain City ("the City").

This Agreement is entered with reference to the following facts.

The City has granted Annexation Petitions which have been filed with the City requesting that the City annex, among other properties, the entire Service Area of the District, including the area occupied by the trunkline and treatment lagoon system owned by the District. The execution of this Agreement is a condition of the proposed Annexation.

The City and the District anticipate that the transfer of facilities from the District to the City and the concurrent transfer of service obligations from the District to the City will occur following the effective date of the annexation in accordance with the terms of this Agreement.

The District and the City further anticipate that following the transfer of the real property, improvements, and funds owned and under the control of the District to the City, the District will proceed to be dissolved as provided by law.

The City and the District desire to facilitate and transfer the sewer facilities and land owned by the District and the service obligations of the District to the City.

NOW, THEREFORE, in consideration of the promises and covenants hereinafter contained, the Parties agree as follows:

1. **Commencement and Termination.** This Agreement shall commence upon execution and shall continue in full force and effect after the annexation described above as long as the District is in operation within the City municipal boundaries, unless otherwise agreed by and between the Parties. Notwithstanding anything herein or elsewhere to the contrary, the provisions of this Agreement establishing the continuing obligation of the City to perpetually serve the area of the District and grant impact fee credit to parties connected to the District system shall survive in perpetuity. Otherwise, this Agreement may be terminated only by mutual agreement between the Parties.

2. **District's Representations.** The District represents to the City that it was formed by the Utah County Commission pursuant to the laws of the State of Utah and that its existence as a Special Service District of the State of Utah has continued in full force and effect from the date of its formation. The District further represents that all actions of the Administrative Control Board or the Utah County Commission have been taken in compliance with the laws of the State of Utah and that the District has the legal authority and is empowered

to execute this Agreement. The District represents to the City that the District system has never knowingly accepted regulated hazardous waste and that to the best of the knowledge of the Administrative Control Board and the Utah County Commissioners, no regulated hazardous waste is present in the collection system or the lagoons owned by the District which would require classification, remediation, transportation, or disposal of any materials in the possession of the District as regulated hazardous waste. The District represents that all funds held by the District now, and in the future, until the termination of the District, are and shall be lawfully imposed, collected and disbursed and are not subject to lawful claims for refund. The District represents that it is the judgment of the Administrative Control Board and the Utah County Commission that it is in the best interests of the public served by the District to enter into this Agreement to provide for the transfer of all of the assets of the District to Eagle Mountain City in return for the City assuming all service obligations of the District and the responsibility for the assets of the District.

3. **Representations of the City.** The City represents that it is a municipal corporation of the State of Utah legally incorporated and existing under the laws of the State of Utah and that it has the full power and legal authority to enter into this Agreement and to construct, own, and operate sewer collection and treatment facilities, including the types of facilities which are owned by the District at the date of this Agreement. The City represents that it has completed an appropriate degree of due diligence with respect to the facilities of the District and is prepared to accept the facilities and funds of the District under the terms of this Agreement. The City hereby irrevocably commits to the District and the owners of property within the District to perpetually provide wastewater collection and treatment service to the persons and properties currently served by the District upon transfer of the District system and assets to the City as required by this Agreement and in accordance with the laws of the State of Utah. The City covenants and agrees to provide perpetual wastewater collection and treatment services to the persons and properties served by the District at the date of Closing and will treat the residents of the properties and property owners in all respects as all other persons and properties in Eagle Mountain City are treated with respect to conditions of service and the payment of fees and costs for wastewater collection and treatment service, particularly in the South Service Area of the City. In particular, but not by way of limitation, all properties connected to the District's wastewater collection system as of the effective date of this Agreement and/or as of the date of Closing shall receive an impact fee and hookup fee credit and shall not be required to pay an impact fee, a hookup fee, or equivalent to the City.

4. **Property and Facilities.** The District is the owner of the wastewater collection system described generally and specifically in Exhibit 1 to this Agreement. The District also owns the land upon which the treatment lagoon system used by the District is planned, constructed and operating and described in Exhibit 2. The collection system, the land, and other assets of the District are not encumbered as collateral for the repayment of any financial obligation and the revenue stream produced by the payment of user charges to the District by those served by the District is not encumbered or pledged for the repayment of any bonds, notes, contracts or other obligations of any nature. The physical facilities of the District described on Exhibits 1 and 2 will be transferred to the City by the District upon the Closing date described in this Agreement.

5. **Financial Assets.** The District holds financial assets that, as of August 4, 2010, are fully disclosed in Exhibit 3 which reflects that the District held the amount of \$105,094.87 in

cash as of that date. At the date of Closing cash assets of the District in a minimum amount of \$90,000.00 will be transferred by the District to the City in cash and deposited in the Sewer Enterprise Fund of the City to be applied to the impact fee credit granted under this Agreement to the properties identified on Exhibit 4 in consideration of the cost for existing collection and treatment capacity incurred by the City to perpetually serve the persons and properties now served by the District. The other assets delivered to the City pursuant to this Agreement serve as additional partial consideration for the referenced impact fee credit. The parties acknowledge that the District will retain cash in an amount estimated to be sufficient to pay the costs of (i) repairs to and operation of the District's system until Closing, (ii) winding up the District's affairs, and (iii) completing the dissolution referenced in paragraph 8 below. Upon dissolution, all remaining cash held by the District will be delivered to and become the property of the City.

6. **Closing of Transfer.** At the Closing of the transaction required by this Agreement, the District will convey to the City by special warranty deed all right, title, and interest of the District in and to all easements and real property and by Bill of Sale or assignment all equipment, accounts receivable, books, records, and other tangible or intangible assets of the District, if any, by executing such deeds, assignments, and other instruments which are approved by Counsel for the Parties. The City will execute a receipt and acknowledgement in a form approved by Counsel for the Parties acknowledging receipt of the funds, properties and all other tangible or intangible assets and liabilities of the District and stating the unequivocal obligation of the City to accept the system reserving only the right of the City to seek recourse for any fraud or intentional misrepresentation resulting in inducement to the City to accept the facilities and service obligations of the District.

7. **Closing Date.** The transfer of facilities and the closing obligations of the Parties shall occur at a date mutually agreed by the Parties, but in any event, no later than fifteen (15) days following the occurrence of the first of any one of the following events:

7.1. The date the District or the City receives notice from the State of Utah Water Quality Board that the treatment system operated by the District must be shut down and the use of the treatment lagoon discontinued.

7.2. The date a trunkline is completed to connect the current District collection system to the South Service Area treatment plant owned and operated by the City.

7.3. The date the lagoon treatment system is connected to service which will require the use of eighty five (85%) percent of the treatment lagoon system designed capacity.

7.4. The Date the Administrative Control Board or the Governing Board of the District finds and gives notice to the City that it is in the public interest to transfer the District's facilities and assets to the City.

Upon the first occurrence of any of the events described above, the Parties shall schedule Closing of the transaction described in this Agreement within fifteen (15) days and complete the transfer of assets and facilities of the system to the City at Closing.

8. **Dissolution of the District.** After the transfer of assets and service obligations defined herein are completed and no further purpose exists for which the District was formed, the Legislative Body of Utah County shall proceed to initiate and conclude the process of dissolution of the District as provided by law.

9. **Counterparts.** This Agreement may be executed in counterparts by the City and the District.

10. **Governing Law.** This Agreement shall be governed by the laws of the State of Utah both as to interpretation and performance.

11. **Utah County Not a Party.** The parties agree that Utah County is not a party to this Agreement and the approval of this Agreement by the Utah County Commission shall not constitute Utah County as a party.

12. **Integration.** This Agreement embodies the entire agreement between the Parties and shall not be altered except in writing signed by both Parties.

IN WITNESS WHEREOF, the Parties have executed this Agreement on the day and year first above written.

EAGLE MOUNTAIN CITY

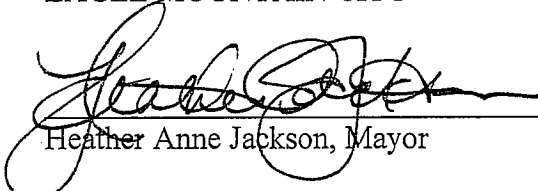
Heather Anne Jackson, Mayor

[SEAL]

Attest:

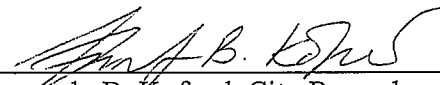
Fionnuala B. Kofoed, City Recorder



Approved as to form and compliance with applicable law:

City Attorney

Date: 9/29/10

Administrative Control Board of the
WHITE HILLS SPECIAL SERVICE
DISTRICT; a Special Service
District of the State of Utah

By:

Its Chairman

BOARD OF COMMISSIONERS OF
UTAH COUNTY, UTAH

By:

Chair

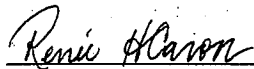

ATTEST:

Clerk - Deputy

Approved as to form and compliance
with applicable law:

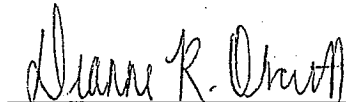
Attorney

Date: 9/14/2010

EXHIBIT

1

WHITE HILLS SPECIAL SERVICE DISTRICT COLLECTION SYSTEM DESCRIPTION

All of the wastewater collection system facilities, including pipelines, manholes, manhole covers, and other associated appurtenances owned by the White Hills Special Service District and lying under and within the public right-of-way and roads as set forth in the recorded plats of the White Hills Subdivision Plat A Amended, Plat B and Plat C including all phases, as recorded in the official plats recorded in the office of the County Recorder of Utah County, Utah.

All of the underground pipelines owned by the White Hills Special Service District lying under and within the right-of-way of State Road 73 adjacent to the intersection of SR73 and the public dedicated roads of the White Hills Subdivision Plat A Amended, according to the official plat thereof in the office of the Utah County Recorder.

All of the District's interest in the underground wastewater collection system used by the District located in the northeast quarter of Section 18, Township 6 South, Range 2 West, Salt Lake Base and Meridian adjacent to or within White Hills Subdivision Plat A, amended; White Hills Subdivision Plat B and White Hills Subdivision Plat C as recorded in the Office of the County Recorder of Utah County, Utah.

All of the interest of the District in and to the wastewater collection facilities located along and under the centerline of the property described below:

Trunkline Centerline Legal Description

BEGINNING FROM THE WEST QUARTER CORNER OF SECTION 17, TOWNSHIP 6 SOUTH, RANGE 2 WEST, SALT LAKE BASE AND MERIDIAN THENCE SOUTH 89°51'20" EAST 644.38 FEET ALONG A SECTION LINE THENCE SOUTH 08°46'45" EAST 61.95 FEET TO A CENTERLINE WHICH BEARS SOUTH 89°34'43" EAST 616.55 FEET; THENCE SOUTH 65°00'00" EAST 350.00 FEET; THENCE SOUTH 89°52'18" EAST 1589.39 FEET TO THE END OF SAID CENTERLINE.

EXHIBIT

2

EXHIBIT 2

Recorded at Request of _____
at _____ M. Fee Paid \$ _____
by _____ Dep. Book _____ Page _____ Ref. _____
Mail tax notice to _____ 40239 _____ Address _____

UTAH COUNTY RECORDERS
RECORDS
1986 NOV 21 AM 11:22
N. HALLIDAY
REC'D

40239

WARRANTY DEED
[CORPORATE FORM]

WHITE HILLS LAND COMPANY, a corporation organized and existing under the laws of the State of Utah, with its principal office at _____ of County of Salt Lake State of Utah, grantor, hereby CONVEYS AND WARRANTS to WHITE HILLS SPECIAL SERVICE DISTRICT

2449 Newcastle Drive
of Sandy, Utah 84092
TEN DOLLARS AND OTHER GOOD AND VALUABLE CONSIDERATION

Warrant for the sum of TEN DOLLARS

the following described tract of land in _____ Utah _____ County, State of Utah:

BEGINNING at a point, said point being 3.178.57 feet South 89°52'18" East from the Northwest corner of the Southwest Quarter of Section 17, Township 6 South, Range 2 West, Salt Lake Base and Meridian; and running thence South 89°52'18" East 815.00 feet, thence South 0°23'32" West 1,339.12 feet, thence North 89°32'53" West 815.00 feet, thence North 0°23'34" East 1,334.52 feet to the point of BEGINNING. (Contains 25.01 Acres.)

The officers who sign this deed hereby certify that this deed and the transfer represented thereby was duly authorized under a resolution duly adopted by the board of directors of the grantor at a lawful meeting duly held and attended by a quorum.

In witness whereof, the grantor has caused its corporate name and seal to be hereunto affixed by its duly authorized officers this 10th day of November, A. D. 1986

Attest: Gloria W. Halliday Secretary, WHITE HILLS LAND Company
By Gary H. White President

STATE OF UTAH,
County of Salt Lake

On the 20th day of November, A. D. 1986 personally appeared before me Gary H. White and Gloria W. Halliday who being by me duly sworn did say, each for himself, that he, the said Gary H. White is the president, and he, the said Gloria W. Halliday is the secretary of White Hills Land Company, and that the within and foregoing instrument was signed in behalf of said corporation by authority of a resolution of its board of directors and said Gary H. White and Gloria W. Halliday each duly acknowledged to me that said corporation executed the same and that the seal affixed is the seal of said corporation.



Gloria W. Halliday
Notary Public
My residence is Salt Lake City, Utah

NOV 23 1986

EXHIBIT

3

8:18 pm
08/04/10
Cash Basis

WHITE HILLS SPECIAL SERVICE DISTRICT
Balance Sheet
As of August 4, 2010

| | <u>Aug 4, 10</u> |
|---------------------------------------|-------------------|
| ASSETS | |
| Current Assets | |
| Checking/Savings | |
| WCB Capital Improvement | 98,170.46 |
| WCB Checking | 5,754.85 |
| WCB Savings | 1,169.56 |
| Total Checking/Savings | <u>105,094.87</u> |
| Accounts Receivable | |
| Accounts Receivable | -170.00 |
| Total Accounts Receivable | <u>-170.00</u> |
| Total Current Assets | <u>104,924.87</u> |
| TOTAL ASSETS | <u>104,924.87</u> |
| LIABILITIES & EQUITY | |
| Equity | |
| Opening Bal Equity | 122,613.59 |
| Retained Earnings | -19,552.22 |
| Net Income | 1,863.50 |
| Total Equity | <u>104,924.87</u> |
| TOTAL LIABILITIES & EQUITY | <u>104,924.87</u> |

EXHIBIT

4

Exhibit 4

Attached are Plat A (amended), Plat B and Plat C of the White Hills Subdivision. All lots having houses and installed sewer connections are reflected on the Plat maps. All previously connected lots are entitled to an impact fee credit as provided in paragraph 3 of the Agreement to which this Exhibit is attached. The only lots on which construction has not started and which, therefore, will be subject to impact fees assessed by the City are: Lots # 9 and # 10 in Plat A (amended) and Lot # 37 in Plat C. All other lots in Plat A (amended), Plat B and Plat C are entitled to receive an impact fee credit as provided in said paragraph 3 and shall not be required to pay a sewer impact fee, a sewer hookup fee, or equivalent, to the City.

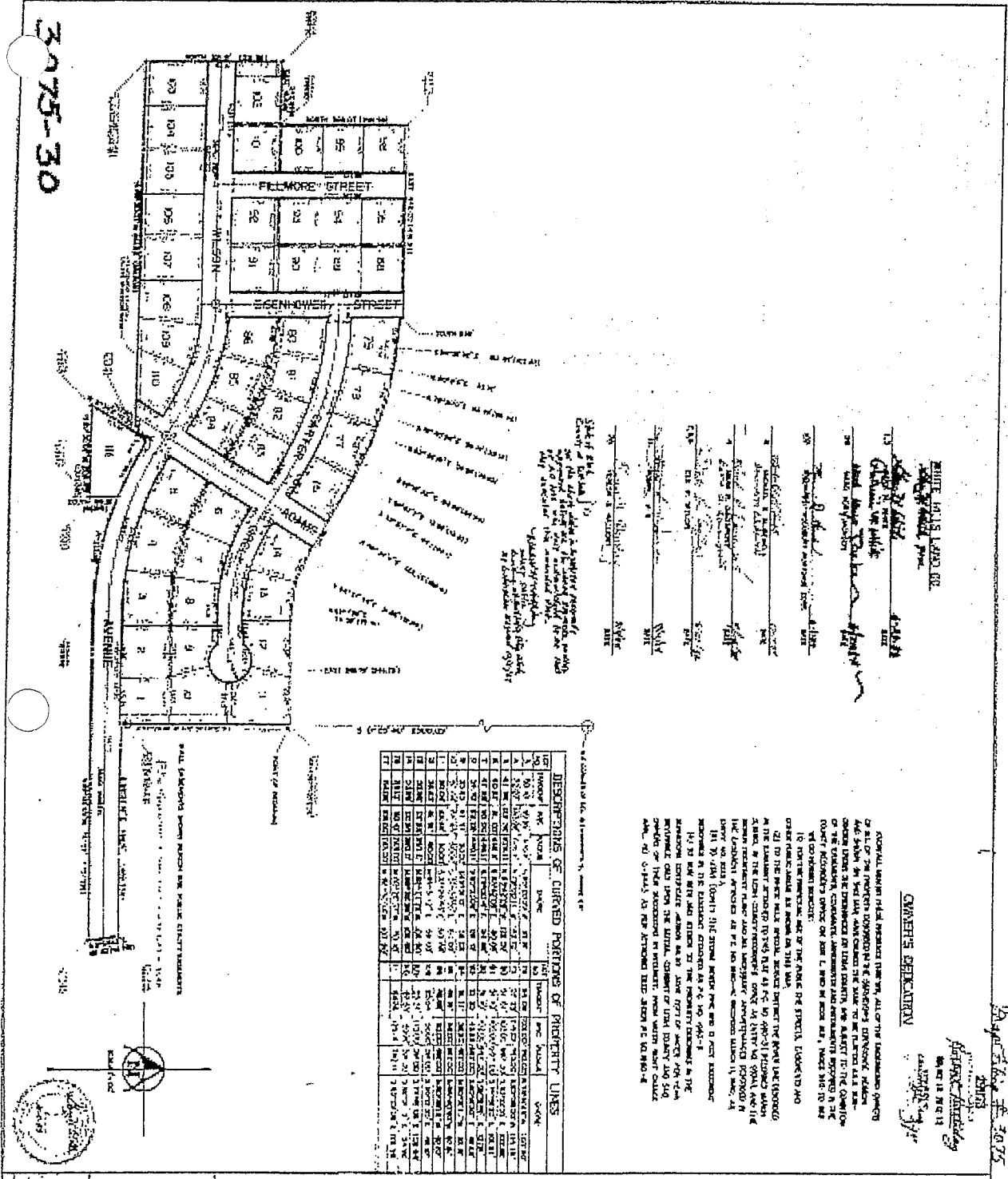

3075-30

WHITE HILLS LOTS 60-116
 60-116
 60-116

60-116
 60-116
 60-116

60-116
 60-116
 60-116

60-116
 60-116
 60-116

60-116
 60-116
 60-116

60-116
 60-116
 60-116

60-116
 60-116
 60-116

60-116
 60-116
 60-116

60-116
 60-116
 60-116

60-116
 60-116
 60-116

60-116
 60-116
 60-116

60-116
 60-116
 60-116

60-116
 60-116
 60-116

60-116
 60-116
 60-116

OWNER'S CERTIFICATE

60-116
 60-116
 60-116

60-116
 60-116
 60-116

60-116
 60-116
 60-116

60-116
 60-116
 60-116

60-116
 60-116
 60-116

60-116
 60-116
 60-116

60-116
 60-116
 60-116

60-116
 60-116
 60-116

60-116
 60-116
 60-116

60-116
 60-116
 60-116

60-116
 60-116
 60-116

60-116
 60-116
 60-116

60-116
 60-116
 60-116

60-116
 60-116
 60-116

60-116
 60-116
 60-116

60-116
 60-116
 60-116

60-116
 60-116
 60-116

60-116
 60-116
 60-116

60-116
 60-116
 60-116

60-116
 60-116
 60-116

60-116
 60-116
 60-116

60-116
 60-116
 60-116

60-116
 60-116
 60-116

60-116
 60-116
 60-116

60-116
 60-116
 60-116

60-116
 60-116
 60-116

60-116
 60-116
 60-116

60-116
 60-116
 60-116

60-116
 60-116
 60-116

60-116
 60-116
 60-116

60-116
 60-116
 60-116

60-116
 60-116
 60-116

60-116
 60-116
 60-116

60-116
 60-116
 60-116

60-116
 60-116
 60-116

60-116
 60-116
 60-116

60-116
 60-116
 60-116

60-116
 60-116
 60-116

| LOT | OWNER'S NAME | DATE | NO. OF SHARES | PER. ACQUIRED | DATE |
|-----|--------------|------|---------------|---------------|------|
| 1 | ... | ... | ... | ... | ... |
| 2 | ... | ... | ... | ... | ... |
| 3 | ... | ... | ... | ... | ... |
| 4 | ... | ... | ... | ... | ... |
| 5 | ... | ... | ... | ... | ... |
| 6 | ... | ... | ... | ... | ... |
| 7 | ... | ... | ... | ... | ... |
| 8 | ... | ... | ... | ... | ... |
| 9 | ... | ... | ... | ... | ... |
| 10 | ... | ... | ... | ... | ... |
| 11 | ... | ... | ... | ... | ... |
| 12 | ... | ... | ... | ... | ... |
| 13 | ... | ... | ... | ... | ... |
| 14 | ... | ... | ... | ... | ... |
| 15 | ... | ... | ... | ... | ... |
| 16 | ... | ... | ... | ... | ... |
| 17 | ... | ... | ... | ... | ... |
| 18 | ... | ... | ... | ... | ... |
| 19 | ... | ... | ... | ... | ... |
| 20 | ... | ... | ... | ... | ... |
| 21 | ... | ... | ... | ... | ... |
| 22 | ... | ... | ... | ... | ... |
| 23 | ... | ... | ... | ... | ... |
| 24 | ... | ... | ... | ... | ... |
| 25 | ... | ... | ... | ... | ... |
| 26 | ... | ... | ... | ... | ... |
| 27 | ... | ... | ... | ... | ... |
| 28 | ... | ... | ... | ... | ... |
| 29 | ... | ... | ... | ... | ... |
| 30 | ... | ... | ... | ... | ... |
| 31 | ... | ... | ... | ... | ... |
| 32 | ... | ... | ... | ... | ... |
| 33 | ... | ... | ... | ... | ... |
| 34 | ... | ... | ... | ... | ... |
| 35 | ... | ... | ... | ... | ... |
| 36 | ... | ... | ... | ... | ... |
| 37 | ... | ... | ... | ... | ... |
| 38 | ... | ... | ... | ... | ... |
| 39 | ... | ... | ... | ... | ... |
| 40 | ... | ... | ... | ... | ... |
| 41 | ... | ... | ... | ... | ... |
| 42 | ... | ... | ... | ... | ... |
| 43 | ... | ... | ... | ... | ... |
| 44 | ... | ... | ... | ... | ... |
| 45 | ... | ... | ... | ... | ... |
| 46 | ... | ... | ... | ... | ... |
| 47 | ... | ... | ... | ... | ... |
| 48 | ... | ... | ... | ... | ... |
| 49 | ... | ... | ... | ... | ... |
| 50 | ... | ... | ... | ... | ... |
| 51 | ... | ... | ... | ... | ... |
| 52 | ... | ... | ... | ... | ... |
| 53 | ... | ... | ... | ... | ... |
| 54 | ... | ... | ... | ... | ... |
| 55 | ... | ... | ... | ... | ... |
| 56 | ... | ... | ... | ... | ... |
| 57 | ... | ... | ... | ... | ... |
| 58 | ... | ... | ... | ... | ... |
| 59 | ... | ... | ... | ... | ... |
| 60 | ... | ... | ... | ... | ... |
| 61 | ... | ... | ... | ... | ... |
| 62 | ... | ... | ... | ... | ... |
| 63 | ... | ... | ... | ... | ... |
| 64 | ... | ... | ... | ... | ... |
| 65 | ... | ... | ... | ... | ... |
| 66 | ... | ... | ... | ... | ... |
| 67 | ... | ... | ... | ... | ... |
| 68 | ... | ... | ... | ... | ... |
| 69 | ... | ... | ... | ... | ... |
| 70 | ... | ... | ... | ... | ... |
| 71 | ... | ... | ... | ... | ... |
| 72 | ... | ... | ... | ... | ... |
| 73 | ... | ... | ... | ... | ... |
| 74 | ... | ... | ... | ... | ... |
| 75 | ... | ... | ... | ... | ... |
| 76 | ... | ... | ... | ... | ... |
| 77 | ... | ... | ... | ... | ... |
| 78 | ... | ... | ... | ... | ... |
| 79 | ... | ... | ... | ... | ... |
| 80 | ... | ... | ... | ... | ... |
| 81 | ... | ... | ... | ... | ... |
| 82 | ... | ... | ... | ... | ... |
| 83 | ... | ... | ... | ... | ... |
| 84 | ... | ... | ... | ... | ... |
| 85 | ... | ... | ... | ... | ... |
| 86 | ... | ... | ... | ... | ... |
| 87 | ... | ... | ... | ... | ... |
| 88 | ... | ... | ... | ... | ... |
| 89 | ... | ... | ... | ... | ... |
| 90 | ... | ... | ... | ... | ... |
| 91 | ... | ... | ... | ... | ... |
| 92 | ... | ... | ... | ... | ... |
| 93 | ... | ... | ... | ... | ... |
| 94 | ... | ... | ... | ... | ... |
| 95 | ... | ... | ... | ... | ... |
| 96 | ... | ... | ... | ... | ... |
| 97 | ... | ... | ... | ... | ... |
| 98 | ... | ... | ... | ... | ... |
| 99 | ... | ... | ... | ... | ... |
| 100 | ... | ... | ... | ... | ... |
| 101 | ... | ... | ... | ... | ... |
| 102 | ... | ... | ... | ... | ... |
| 103 | ... | ... | ... | ... | ... |
| 104 | ... | ... | ... | ... | ... |
| 105 | ... | ... | ... | ... | ... |
| 106 | ... | ... | ... | ... | ... |
| 107 | ... | ... | ... | ... | ... |
| 108 | ... | ... | ... | ... | ... |
| 109 | ... | ... | ... | ... | ... |
| 110 | ... | ... | ... | ... | ... |
| 111 | ... | ... | ... | ... | ... |
| 112 | ... | ... | ... | ... | ... |
| 113 | ... | ... | ... | ... | ... |
| 114 | ... | ... | ... | ... | ... |
| 115 | ... | ... | ... | ... | ... |
| 116 | ... | ... | ... | ... | ... |

DESCRIPTIONS OF CURVED PORTIONS OF PROPERTY LINES

1. THE CURVED PORTION OF THE PROPERTY LINE BETWEEN LOTS 1 AND 2 IS DESCRIBED AS FOLLOWS: A CURVED LINE WITH A RADIUS OF 100 FEET, BEING 1/4 OF A CIRCLE OF 90 DEGREES, CENTERED AT THE POINT OF INTERSECTION OF THE STRAIGHT LINES ADJACENT TO THE CURVED PORTION.

2. THE CURVED PORTION OF THE PROPERTY LINE BETWEEN LOTS 2 AND 3 IS DESCRIBED AS FOLLOWS: A CURVED LINE WITH A RADIUS OF 100 FEET, BEING 1/4 OF A CIRCLE OF 90 DEGREES, CENTERED AT THE POINT OF INTERSECTION OF THE STRAIGHT LINES ADJACENT TO THE CURVED PORTION.

...

116. THE CURVED PORTION OF THE PROPERTY LINE BETWEEN LOTS 115 AND 116 IS DESCRIBED AS FOLLOWS: A CURVED LINE WITH A RADIUS OF 100 FEET, BEING 1/4 OF A CIRCLE OF 90 DEGREES, CENTERED AT THE POINT OF INTERSECTION OF THE STRAIGHT LINES ADJACENT TO THE CURVED PORTION.

White Hills
 3075-30

PLAT A

...

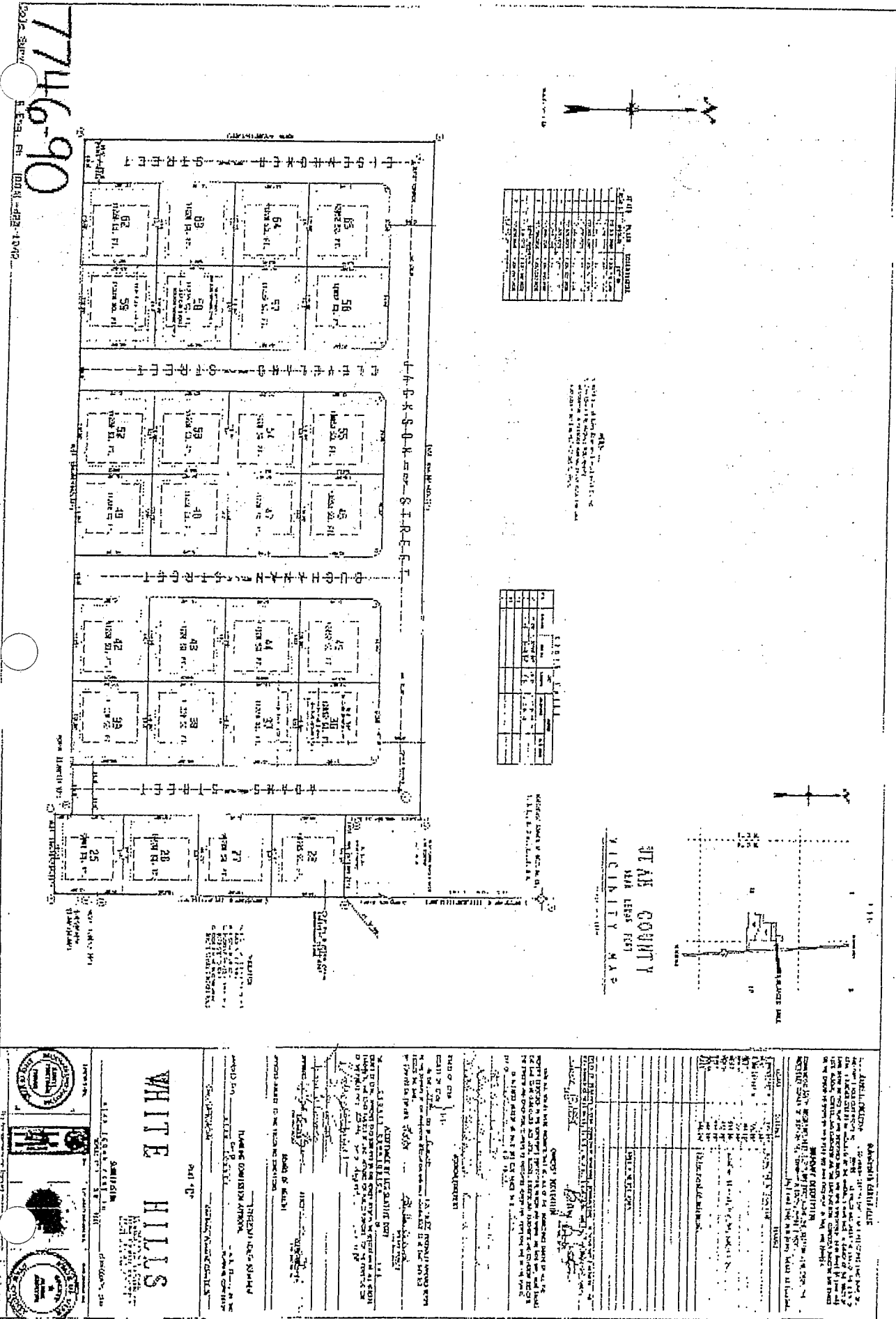

7746-90

2011-2012

FILE PLAN SUMMARY

| LOT NO. | ACRES | AREA (SQ. FT.) | PERCENTAGE OF TOTAL |
|---------|--------|----------------|---------------------|
| 25 | 0.125 | 5,455 | 0.125 |
| 26 | 0.125 | 5,455 | 0.125 |
| 27 | 0.125 | 5,455 | 0.125 |
| 28 | 0.125 | 5,455 | 0.125 |
| 29 | 0.125 | 5,455 | 0.125 |
| 30 | 0.125 | 5,455 | 0.125 |
| 31 | 0.125 | 5,455 | 0.125 |
| 32 | 0.125 | 5,455 | 0.125 |
| 33 | 0.125 | 5,455 | 0.125 |
| 34 | 0.125 | 5,455 | 0.125 |
| 35 | 0.125 | 5,455 | 0.125 |
| 36 | 0.125 | 5,455 | 0.125 |
| 37 | 0.125 | 5,455 | 0.125 |
| 38 | 0.125 | 5,455 | 0.125 |
| 39 | 0.125 | 5,455 | 0.125 |
| 40 | 0.125 | 5,455 | 0.125 |
| 41 | 0.125 | 5,455 | 0.125 |
| 42 | 0.125 | 5,455 | 0.125 |
| 43 | 0.125 | 5,455 | 0.125 |
| 44 | 0.125 | 5,455 | 0.125 |
| 45 | 0.125 | 5,455 | 0.125 |
| 46 | 0.125 | 5,455 | 0.125 |
| 47 | 0.125 | 5,455 | 0.125 |
| 48 | 0.125 | 5,455 | 0.125 |
| 49 | 0.125 | 5,455 | 0.125 |
| 50 | 0.125 | 5,455 | 0.125 |
| 51 | 0.125 | 5,455 | 0.125 |
| 52 | 0.125 | 5,455 | 0.125 |
| 53 | 0.125 | 5,455 | 0.125 |
| 54 | 0.125 | 5,455 | 0.125 |
| 55 | 0.125 | 5,455 | 0.125 |
| 56 | 0.125 | 5,455 | 0.125 |
| 57 | 0.125 | 5,455 | 0.125 |
| 58 | 0.125 | 5,455 | 0.125 |
| 59 | 0.125 | 5,455 | 0.125 |
| 60 | 0.125 | 5,455 | 0.125 |
| 61 | 0.125 | 5,455 | 0.125 |
| 62 | 0.125 | 5,455 | 0.125 |
| 63 | 0.125 | 5,455 | 0.125 |
| 64 | 0.125 | 5,455 | 0.125 |
| 65 | 0.125 | 5,455 | 0.125 |
| TOTAL | 15.625 | 706,875 | 100.000 |

NOTICE: The above plat is subject to the following conditions:

1. The plat is subject to the provisions of the plat of the White Hills.
2. The plat is subject to the provisions of the plat of the White Hills.
3. The plat is subject to the provisions of the plat of the White Hills.

FILE PLAN SUMMARY

| LOT NO. | ACRES | AREA (SQ. FT.) | PERCENTAGE OF TOTAL |
|---------|--------|----------------|---------------------|
| 25 | 0.125 | 5,455 | 0.125 |
| 26 | 0.125 | 5,455 | 0.125 |
| 27 | 0.125 | 5,455 | 0.125 |
| 28 | 0.125 | 5,455 | 0.125 |
| 29 | 0.125 | 5,455 | 0.125 |
| 30 | 0.125 | 5,455 | 0.125 |
| 31 | 0.125 | 5,455 | 0.125 |
| 32 | 0.125 | 5,455 | 0.125 |
| 33 | 0.125 | 5,455 | 0.125 |
| 34 | 0.125 | 5,455 | 0.125 |
| 35 | 0.125 | 5,455 | 0.125 |
| 36 | 0.125 | 5,455 | 0.125 |
| 37 | 0.125 | 5,455 | 0.125 |
| 38 | 0.125 | 5,455 | 0.125 |
| 39 | 0.125 | 5,455 | 0.125 |
| 40 | 0.125 | 5,455 | 0.125 |
| 41 | 0.125 | 5,455 | 0.125 |
| 42 | 0.125 | 5,455 | 0.125 |
| 43 | 0.125 | 5,455 | 0.125 |
| 44 | 0.125 | 5,455 | 0.125 |
| 45 | 0.125 | 5,455 | 0.125 |
| 46 | 0.125 | 5,455 | 0.125 |
| 47 | 0.125 | 5,455 | 0.125 |
| 48 | 0.125 | 5,455 | 0.125 |
| 49 | 0.125 | 5,455 | 0.125 |
| 50 | 0.125 | 5,455 | 0.125 |
| 51 | 0.125 | 5,455 | 0.125 |
| 52 | 0.125 | 5,455 | 0.125 |
| 53 | 0.125 | 5,455 | 0.125 |
| 54 | 0.125 | 5,455 | 0.125 |
| 55 | 0.125 | 5,455 | 0.125 |
| 56 | 0.125 | 5,455 | 0.125 |
| 57 | 0.125 | 5,455 | 0.125 |
| 58 | 0.125 | 5,455 | 0.125 |
| 59 | 0.125 | 5,455 | 0.125 |
| 60 | 0.125 | 5,455 | 0.125 |
| 61 | 0.125 | 5,455 | 0.125 |
| 62 | 0.125 | 5,455 | 0.125 |
| 63 | 0.125 | 5,455 | 0.125 |
| 64 | 0.125 | 5,455 | 0.125 |
| 65 | 0.125 | 5,455 | 0.125 |
| TOTAL | 15.625 | 706,875 | 100.000 |

STATE OF ARIZONA
YAVAPAI COUNTY
VICINITY MAP

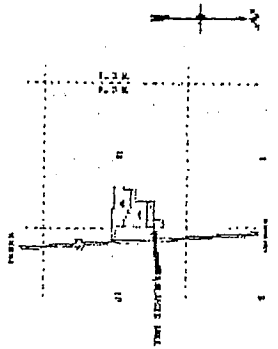

NOTICE: The above plat is subject to the following conditions:

1. The plat is subject to the provisions of the plat of the White Hills.
2. The plat is subject to the provisions of the plat of the White Hills.
3. The plat is subject to the provisions of the plat of the White Hills.

WHITE HILLS



Exhibit 11 – Local District Agreement

INTERLOCAL COOPERATION AGREEMENT
BETWEEN
POLE CANYON LOCAL DISTRICT

-AND-

EAGLE MOUNTAIN CITY

THIS AGREEMENT is made and entered into the 21 day of December, 2009, by and between Eagle Mountain City ("City"), and Pole Canyon Local District ("the District"), a basic local District of the State of Utah.

WITNESSETH:

WHEREAS, the City and the District desire to facilitate the improvement of the area to be annexed to the City concurrent with the execution of this Agreement and located in Eagle Mountain City, Utah, commonly known as "Pole Canyon", by providing a mechanism for the installation of various improvements; and

WHEREAS, the City and the District acknowledge that significant on-site and off-site public infrastructure and other related improvements, including but not limited to roads, sewer, water and storm drainage systems, utilities systems, and public recreation and other facilities and public improvements (collectively "Public Improvements") may be required in connection with the development of the Pole Canyon area; and

WHEREAS, the District and the City have agreed pursuant hereto to cooperate in good faith to consider the financing, installation and provision of certain Public Improvements within the legal authority of the District which are limited to transportation, sewer, water and storm drainage systems, electric utilities systems, and public recreation, in an effort to ensure a timely implementation, as provided more fully herein; and

WHEREAS, in light of the public benefits and costs associated with the Public Improvements, the acquisition and/or construction of the Public Improvements will be financed consistent with the terms of this Agreement, which Agreement contemplates among other things, as more fully set forth below, the issuance of public and/or special assessment bonds, and other forms of public financing; and

WHEREAS, the District was established as a mechanism to facilitate residents and property owners in a certain portion of the Cedar Valley, Utah County, Utah area, which certain property is more fully depicted in Exhibit A attached hereto and incorporated herein (the "District Area"), to finance the needed infrastructure installation, and was not established and does not exist to own and operate the completed infrastructure, unless, at its sole discretion, the City defers operation of any particular improvement back to the District; and

WHEREAS, the City has agreed to the ultimate ownership and responsibility of the Public Improvements in order to ensure its continued viability and proper maintenance; and

WHEREAS, both parties are public agencies authorized by 11-13-101 et seq of the Utah State Code to make the most efficient use of their powers by enabling them to operate with each other on a basis of mutual advantage and thereby provide services and facilities in a manner and under forms of governmental organization that will accord best with geographic, economic, and other factors influencing the needs of this growing community;

NOW, THEREFORE, in consideration of the promises and covenants hereinafter contained, the parties agree as follows:

1. **Commencement and Termination.** This agreement shall commence upon execution and shall continue in full force and effect as long as the District is in operation within municipal boundaries, unless otherwise agreed by and between the parties. Otherwise, this Agreement may be terminated only by mutual agreement between the parties.

2. **Scope of Agreement.**

A. This Agreement sets forth the terms and conditions under which the District and the City will coordinate and facilitate the financing and installation of various Public Improvements within or to benefit the District Area as well as other property located beyond the geographic limits of the District Area, pursuant to the standards and requirements set forth by the City. In general, with respect the financing of the Public Improvements that will be coordinated by the City and the District pursuant to this Agreement, the District acknowledges that it will have primary responsibility to consider financing such Public Improvements (through Special Assessment Area ("SAA") bonds or otherwise) which service and/or benefit only the District Area or a portion thereof (the "District Specific Public Improvements"). If the District is unable to locate adequate financing for such District Specific Public Improvements, the City may consider assisting the District with bonding for such District Specific Public Improvements

within the Property, when reasonable and determined by the City to be in its interest to do so. In the event that the necessary Public Improvements benefit property owners and property beyond the geographic limits of the District Area in addition to benefitting the District Area (the "Additional Property Public Improvements"), then the City agrees to consider providing assessment bonding or other financing for such specific Additional Property Public Improvements. In the event that the District is unable to locate adequate financing for the District Specific Public Improvements (and the City elects not to assist the District in obtaining such financing), and further, if the City is unable to procure financing for such Additional Property Public Improvements or otherwise elects not to provide such financing, then the City and the District acknowledge that financing for such Public Improvements may be required to be provided through alternative sources. In the event that the financing comes from private sources (i.e., development financing), the City acknowledges that appropriate impact fee credits and/or reimbursements shall be provided, in accordance with and subject to the Utah Impact Fees Act, Utah Code Ann. §§ 11-36-101 *et seq.* (the "Impact Fees Act").

With respect to those District Specific Public Improvements to be financed by the District, the District shall solely bear the cost of such Public Improvements by utilizing the funds generated by the District through the collection of property taxes and the creation of SAAs and/or other public financing mechanisms available to the District under applicable law, Interlocal Agreements, and other mechanisms it deems necessary, until such time as the Improvements are turned over to the City.

B. The District shall notify the City when it finds that each proposed improvement is considered for construction and nominate at least two qualified engineering firms for consideration by the City. After approval by the City of the engineer for the proposed project, the District shall supervise and develop the appropriate engineered plans for the District Specific Public Improvements financed by the District, coordinate the review of draft plans by the City and shall present the engineering plans and designs to the City for approval. Upon obtaining the City's approval, the District shall bid the project design approved by the City and construct and install the District Specific Public Improvements subject to the City's inspection and approval.

C. The City's role including pre-bid meetings with contractors and post contract award preconstruction conferences with contractors and the periodic inspection of the

construction of such improvements financed by the District, and the costs of same, shall be governed by the City's customary policies and procedures governing other projects and developers within the City.

D. Within 90 days of completion of the District Specific Public Improvements and final written acceptance of the improvements by the City, the right, title and interest to such Improvements shall pass to the City by record dedication acceptable to the City and the City shall take ownership and operation and maintenance obligations of such District Specific Public Improvements.

3. **Cost and Financing.** As set forth above, the District will likely finance the costs of the construction and installation of the District Specific Public Improvements. This shall be done at the sole risk and responsibility of the District. The Parties agree and understand that the City shall take ownership of the District Specific Public Improvements financed by the District free and clear of any debt incurred to finance the cost of construction. Such costs shall continue to be borne by the District and shall be covered by the service fees and other agreement fees generated by the improvements. Notwithstanding the foregoing, the City acknowledges that under the Impact Fees Act, the property owners which have serviced the bond obligations associated with the District Specific Public Improvements may be entitled to impact fee credits and/or reimbursements for the payments made by such owners. In consideration of the mutual services performed under this Agreement, the City and the District shall provide for their various and mutually exclusive services at no cost to the other.

4. **Phase One Public Improvements.** Notwithstanding the foregoing, the District and the City acknowledge and agree that certain Public Improvements have been planned by the District, the City and private property owners as initial "phase one" improvements to be provided as soon as reasonably possible (the "Phase One Improvements"). The Phase One Improvements are more particularly identified on Exhibit B attached hereto and incorporated herein, and designate both District Specific Public Improvements and Additional Property Public Improvements. The City and the District agree that they will each initiate the process of establishing and issuing SAA or other acceptable bonds for the financing of the applicable Phase One Improvements identified on Exhibit B, provided that nothing herein shall alter or limit the legally mandated public process required to establish such bonding.

5. Other Issues.

A. It is the sole responsibility of the District to facilitate and set up any necessary special service areas as individual neighborhood planning areas covered by the District are approved by the City. The City is responsible for special service areas outside of the Districts areas and the District shall have no responsibilities for such areas.

B. The District is not authorized to provide services for other utilities such as over head power, natural gas and telecommunications. The City shall be responsible to facilitate special service areas to provide for the implementation of the infrastructure for those services.

6. Governmental Immunity. The District and the City are governmental entities and subject to the Governmental Immunity Act of Utah, Utah Code Ann. §§ 63-30d-1, et seq. ("Act"). Subject to the provisions of the Act, each of the Parties agree to indemnify and hold harmless the other party, its agents, officers and employees from and against any and all actions, claims, lawsuits, proceedings, liability damages, losses and expenses (including attorney's fees and costs) arising out of or resulting from the performance of this Agreement to the extent the same are caused by any negligent or wrongful act or omission of that party, its officers, agents and employees. Nothing in this Agreement shall be deemed a waiver of any rights, statutory limitations on liability, or defenses applicable to the Parties under the Act.

7. Interlocal Agreement. In satisfaction of the requirements of the Interlocal Cooperation Act, Title 11, Chapter 13, Utah Code Annotated 1953, as amended ("Interlocal Act"), in connection with this Agreement, the City and The District agree as follows:

- (a) This Agreement shall be approved by each party, Pursuant to § 11-13-202.5 of the Interlocal Act;
- (b) This Agreement shall be reviewed as to proper form and compliance with applicable law by a duly authorized attorney on behalf of each party, pursuant to Section 11-13-202.5 of the Interlocal Act ;
- (c) A duly executed original counterpart of the Agreement shall be filed with the keeper of records of each party, pursuant to § 11-13-209 of the Interlocal Act;
- (d) Each party shall be responsible for its own costs of any action done pursuant to this Agreement, and for any financing of such costs; and

(e) No separate legal entity is created by the terms of this Agreement. To the extent that this Agreement requires administration other than as set forth herein, it shall be administered by the City Recorder of the City and the Executive Director of The District, acting as a joint board. No real or personal property shall be acquired jointly by the parties as a result of this Agreement. To the extent that a party acquires, holds, and disposes of any real or personal property for use in the joint or cooperative undertaking contemplated by this Agreement, such party shall do so in the same manner that it deals with other property of such party.

8. **Counterparts.** This Agreement may be executed in counterparts by the City and The District.

9. **Governing Law.** This Agreement shall be governed by the laws of the State of Utah both as to interpretation and performance.

10. **Integration.** This Agreement embodies the entire agreement between the parties and shall not be altered except in writing signed by both parties.

[Signatures on Next Page.]

IN WITNESS WHEREOF, the parties have executed this Agreement on the day
and year first above written.

EAGLE MOUNTAIN CITY

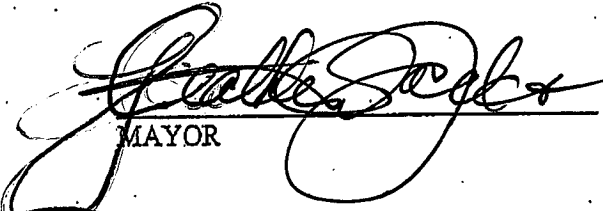
MAYOR

[SEAL]

Attest:

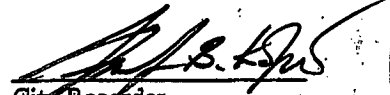
City Recorder

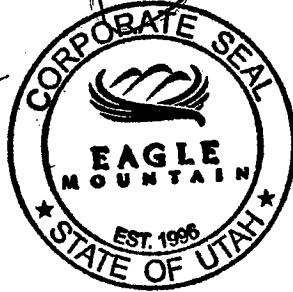

Approved as to form and compliance
with applicable law:

City Attorney

Date: 12-21-09

POLE CANYON LOCAL DISTRICT

By [Signature]
Its President

STATE OF UTAH)

County of Salt Lake)

On this 21 day of December 2009, personally appeared before me NATHAN D. STUBBS who being duly sworn, did say that (s)he is the President of Pole Canyon Local District, and that the foregoing instrument was signed on behalf of the District, by authority of law.



[Signature]
NOTARY PUBLIC
Residing in Salt Lake County, Utah

Approved as to form and compliance
with applicable law:

Attorney
Date: _____

EXHIBIT “A”

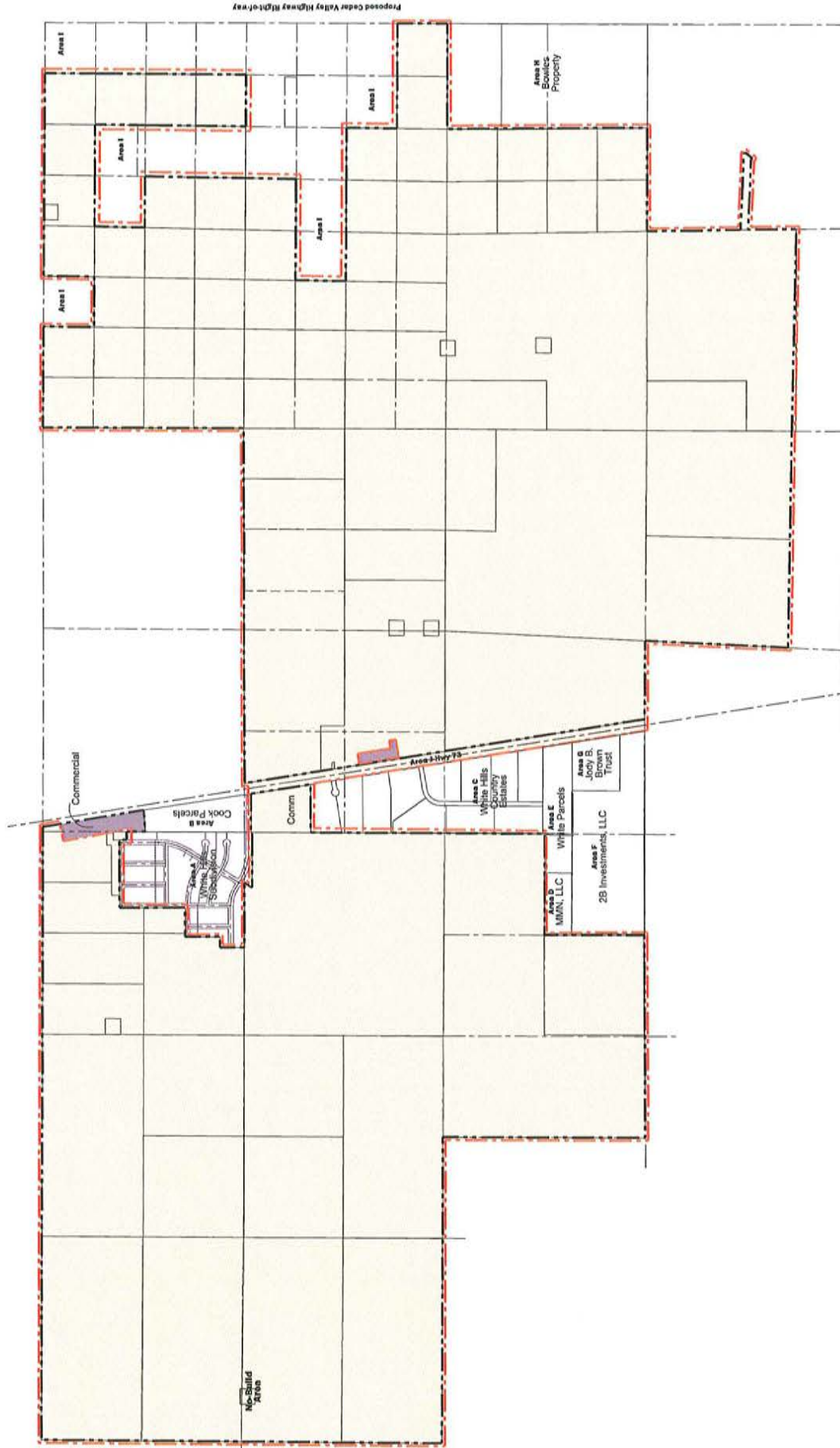

Pole Canyon Basic Local District



ASWT

Local Area District Boundary

BOUNDARY DESCRIPTIONS

LAND LYING IN SECTION 16, THE SOUTH 1/4 SECTION 17, SECTION 18, THE NORTH 1/4 SECTION 19, THE NW 1/4, THE NE 1/4 AND THE SE 1/4 SECTION 20 AND IN SECTION 21, TOWNSHIP 6 SOUTH, RANGE 2 WEST, SALT LAKE BASE AND MERIDIAN, AND IN THE EAST 1/2 OF SECTION 13, TOWNSHIP 6 SOUTH, RANGE 3 WEST, SALT LAKE BASE AND MERIDIAN, DESCRIBED AS FOLLOWS:

BEGINNING AT THE NORTHEAST CORNER OF SECTION 18, TOWNSHIP 6 SOUTH, RANGE 2 WEST, SALT LAKE BASE & MERIDIAN, AND RUNNING SOUTH 89°30'22" EAST, 61.03 FEET ALONG THE SECTION LINE TO THE WESTERLY RIGHT-OF-WAY LINE OF STATE ROUTE NO. 73; THENCE SOUTH 08°40'29" EAST, 178.00 FEET ALONG SAID RIGHT-OF-WAY LINE; THENCE LEAVING SAID RIGHT-OF-WAY LINE AND RUNNING ALONG THE BOUNDARY LINE OF THE WILLIAM H. AND TERESA WILSON PROPERTY (DEVELOPMENT AGREEMENT) IN THE FOLLOWING TWO COURSES: SOUTH 81°19'31" WEST, 220.00 FEET; THENCE SOUTH 08°40'29" EAST, 731.76 FEET TO THE NORTH BOUNDARY LINE OF THE WHITE HILLS WATER CONSERVANCY PROPERTY; THENCE WEST 97.58 FEET ALONG SAID NORTH BOUNDARY LINE; THENCE NORTH 00°01'20" EAST, 23.15 FEET; THENCE NORTH 89°58'40" WEST, 1004.00 FEET; THENCE SOUTH 00°01'20" WEST, 870.00 FEET; THENCE NORTH 89°58'40" WEST, 278.00 FEET; THENCE SOUTH 00°01'20" WEST, 110.00 FEET TO THE WEST BOUNDARY LINE OF "WHITE HILLS SUBDIVISION PLAT B"; THENCE SOUTH 00°01'20" WEST, 163.52 FEET ALONG SAID WEST BOUNDARY LINE TO THE WEST BOUNDARY LINE OF "WHITE HILLS SUBDIVISION PLAT A AMENDED"; THENCE ALONG THE WEST AND SOUTH BOUNDARY OF SAID SUBDIVISION IN THE FOLLOWING NINE COURSES: SOUTH 00°01'20" WEST, 300.00 FEET; THENCE NORTH 89°58'40" W, 143.00 FEET; THENCE SOUTH 00°01'20" WEST, 321.15 FEET; THENCE SOUTH 89°28'47" EAST, 851.85 FEET; THENCE SOUTH 31°31'20" WEST, 117.29 FEET; THENCE SOUTH 89°28'47" EAST, 209.45 FEET; THENCE NORTH 00°01'20" EAST, 66.13 FEET TO A POINT ON THE ARC OF A 742.11 FOOT RADIUS CURVE TO THE LEFT, THE BEARING TO RADIUS POINT BEING NORTH 21°33'08" EAST; THENCE EASTERLY 273.40 FEET ALONG THE ARC OF SAID CURVE THROUGH A CENTRAL ANGLE OF 21°06'30" TO THE POINT OF TANGENCY; THENCE SOUTH 89°33'23" EAST, 809.98 FEET ALONG SAID SUBDIVISION BOUNDARY LINE AND THE PROLONGATION THEREOF TO THE EASTERLY RIGHT-OF-WAY LINE OF "STATE ROUTE NO. 73"; THENCE NORTH 08°40'29" WEST, 87.84 FEET ALONG SAID RIGHT-OF-WAY LINE TO A POINT ON THE EAST-WEST CENTER SECTION LINE OF SECTION 17, TOWNSHIP 6 SOUTH, RANGE 2 WEST, SALT LAKE BASE & MERIDIAN; THENCE SOUTH 89°51'20" EAST, 2021.71 FEET ALONG SAID CENTER SECTION LINE TO THE CENTER 1/4 CORNER OF SAID SECTION 17; THENCE SOUTH 89°51'20" EAST, 512.21 FEET ALONG THE CENTER SECTION LINE TO THE WEST BOUNDARY LINE OF THE "WHITE HILLS SPECIAL SERVICE DISTRICT" PROPERTY RECORDED AS ENTRY # 040239-1986, IN THE OFFICE OF THE RECORDER FOR UTAH COUNTY, STATE OF UTAH; THENCE ALONG THE BOUNDARY LINE OF SAID PROPERTY IN THE FOLLOWING THREE COURSES: SOUTH 00°23'34" WEST, 1336.39 FEET TO THE SOUTH 1/16 LINE; THENCE SOUTH 89°40'18" EAST, 811.68 FEET ALONG THE SOUTH 1/16 LINE; THENCE NORTH 00°30'03" EAST, 1339.00 FEET TO THE CENTER SECTION LINE; THENCE SOUTH 89°51'20" EAST, 1326.43 FEET ALONG THE CENTER SECTION LINE TO THE EAST 1/4 CORNER OF SAID SECTION 17; THENCE NORTH 00°23'57" EAST, 2688.89 FEET ALONG THE SECTION LINE TO THE NORTHWEST CORNER OF SECTION 16, TOWNSHIP 6 SOUTH, RANGE 2 WEST, SALT LAKE BASE & MERIDIAN; THENCE SOUTH 89°22'57" EAST, 1333.51 FEET ALONG THE SECTION LINE TO THE WEST BOUNDARY OF THE "SARIEL" PROPERTY, SERIAL NO. 59-048-0072; THENCE ALONG SAID BOUNDARY IN THE FOLLOWING THREE COURSES: SOUTH 00°55'27" WEST, 667.59 FEET; THENCE SOUTH 89°22'01" EAST, 663.70 FEET; THENCE NORTH 01°11'12" EAST, 667.79 FEET TO THE SECTION LINE; THENCE SOUTH 89°22'57" EAST, 666.76 FEET TO THE NORTH 1/4 CORNER OF SAID SECTION 16; THENCE SOUTH 89°23'26" EAST, 2000.84 FEET TO THE NORTHEAST CORNER OF THE NORTHEAST 1/4 OF THE NORTHEAST 1/4 OF THE NORTHEAST 1/4 OF SAID SECTION 16; THENCE SOUTH 00°37'53" WEST, 2874.28 FEET TO THE SOUTHEAST CORNER OF THE SOUTHWEST 1/4 OF THE SOUTHEAST 1/4 OF THE NORTHEAST 1/4 OF SAID SECTION 16; THENCE NORTH 89°19'10" WEST, 679.55 FEET ALONG THE CENTER SECTION LINE TO THE SOUTHWEST CORNER OF THE SOUTHWEST 1/4 OF THE SOUTHEAST 1/4 OF THE NORTHEAST 1/4 OF SAID SECTION 16; THENCE NORTH 00°54'13" EAST, 2095.11 FEET TO THE SOUTHEAST CORNER OF THE NORTHEAST 1/4 OF THE NORTHWEST 1/4 OF THE NORTHEAST 1/4 OF SAID SECTION 16; THENCE NORTH 89°22'21" WEST, 1340.05 FEET TO THE NORTHWEST CORNER OF THE SOUTHWEST 1/4 OF THE NORTHWEST 1/4 OF THE NORTHEAST 1/4 OF SAID SECTION 16; THENCE SOUTH 01°26'55" WEST, 688.01 FEET TO THE SOUTHWEST CORNER OF THE SOUTHWEST 1/4 OF THE NORTHWEST 1/4 OF THE NORTHEAST 1/4 OF SAID SECTION 16; THENCE SOUTH 89°21'16" EAST, 673.20 FEET TO THE SOUTHEAST CORNER OF THE SOUTHWEST 1/4 OF THE NORTHWEST 1/4 OF THE NORTHEAST 1/4 OF SAID SECTION 16; THENCE SOUTH 01°10'34" WEST, 1336.36 FEET TO THE SOUTHEAST CORNER OF THE SOUTHWEST 1/4 OF THE SOUTHWEST 1/4 OF THE NORTHEAST 1/4 OF SAID SECTION 16; THENCE SOUTH 01°11'37" WEST, 670.14 FEET TO THE SOUTHWEST CORNER OF THE NORTHWEST 1/4 OF THE NORTHWEST 1/4 OF THE NORTHEAST 1/4 OF SAID SECTION 16; THENCE NORTH 89°24'20" WEST, 682.55 FEET TO THE SOUTHWEST CORNER OF THE NORTHWEST 1/4 OF THE NORTHWEST 1/4 OF THE NORTHEAST 1/4 OF SAID SECTION 16; THENCE SOUTH 01°11'10" WEST, 671.29 FEET TO THE SOUTHWEST CORNER OF THE SOUTHWEST 1/4 OF THE NORTHEAST 1/4 OF THE NORTHEAST 1/4 OF SAID SECTION 16; THENCE SOUTH 89°20'26" EAST, 646.38 FEET TO THE SOUTHWEST CORNER OF THE SOUTHWEST 1/4 OF THE NORTHEAST 1/4 OF THE SOUTHWEST 1/4 OF SAID SECTION 16; THENCE SOUTH 89°22'27" EAST, 1371.10 FEET TO THE NORTHEAST CORNER OF THE NORTHEAST 1/4 OF THE SOUTHWEST 1/4 OF THE SOUTHWEST 1/4 OF SAID SECTION 16; THENCE SOUTH 00°00'14" WEST, 864.10 FEET TO THE SOUTHWEST CORNER OF THE NORTHEAST 1/4 OF THE SOUTHWEST 1/4 OF THE SOUTHWEST 1/4 OF SAID SECTION 16; THENCE SOUTH 89°34'32" EAST, 1377.10 FEET TO THE NORTHEAST CORNER OF THE SOUTHWEST 1/4 OF THE SOUTHWEST 1/4 OF THE SOUTHWEST 1/4 OF SAID SECTION 16; THENCE SOUTH 00°25'25" WEST, 667.04 FEET ALONG THE SECTION LINE TO THE SOUTHWEST CORNER OF SAID SECTION 16; THENCE NORTH 89°39'34" WEST, 1383.11 FEET ALONG THE SECTION LINE TO THE NORTHEAST CORNER OF THE NORTHWEST 1/4 OF THE NORTHEAST 1/4 OF SECTION 21, TOWNSHIP 6 SOUTH, RANGE 2 WEST, SALT LAKE BASE & MERIDIAN; THENCE SOUTH 00°07'26" EAST, 2655.86 FEET ALONG THE EAST 1/16 LINE TO THE SOUTHWEST CORNER OF THE SOUTHWEST 1/4 OF THE NORTHEAST 1/4 OF SAID SECTION 21; THENCE NORTH 89°38'49" WEST, 1359.07 FEET ALONG THE EAST-WEST CENTER SECTION LINE TO THE CENTER 1/4 OF SAID SECTION 21; THENCE SOUTH 00°37'47" EAST, 1243.93 FEET ALONG THE CENTER SECTION LINE; THENCE SOUTH 87°12'10" EAST, 1001.36 FEET TO THE WEST BOUNDARY LINE OF THE LEH TO FAIRFIELD ROAD; THENCE SOUTH 51°20'10" EAST, 28.00 FEET TO THE CENTERLINE OF SAID ROAD; THENCE SOUTH 38°30'50" WEST, 123.17 FEET ALONG SAID CENTERLINE; THENCE NORTH 51°20'10" WEST, 28.00 FEET TO THE WEST BOUNDARY LINE OF SAID ROAD; THENCE NORTH 87°12'10" WEST, 823.22 FEET TO THE CENTER SECTION LINE; THENCE SOUTH 00°37'47" EAST, 643.56 FEET ALONG THE CENTER SECTION LINE TO THE NORTH BOUNDARY LINE OF 2500 NORTH STREET; THENCE LEAVING THE CENTER SECTION LINE AND RUNNING NORTH 88°30'22" WEST, 2684.40 FEET ALONG SAID NORTH BOUNDARY LINE TO THE WEST LINE OF THE SOUTHWEST 1/4 OF SAID SECTION 21, BEING THE EAST LINE OF THE SOUTHWEST 1/4 OF SECTION 20, TOWNSHIP 6 SOUTH, RANGE 2 WEST, SALT LAKE BASE & MERIDIAN; THENCE NORTH 88°40'08" WEST, 2853.85 FEET TO THE NORTH-SOUTH CENTER SECTION LINE OF SAID SECTION 20; THENCE NORTH 02°26'34" EAST, 1905.75 FEET ALONG THE SECTION LINE TO THE CENTER 1/4 CORNER OF SAID SECTION 20; THENCE NORTH 89°21'12" WEST, 2549.27 FEET ALONG THE EAST-WEST CENTER SECTION LINE TO THE EAST 1/4 CORNER OF SAID SECTION 20; THENCE NORTH 89°54'53" WEST, 4000.34 FEET ALONG THE EAST-WEST CENTER SECTION LINE OF SECTION 19, TOWNSHIP 6 SOUTH, RANGE 2 WEST, SALT LAKE BASE & MERIDIAN TO THE SOUTHWEST CORNER OF THE SOUTHWEST 1/4 OF THE NORTHWEST 1/4 OF SAID SECTION 19; THENCE NORTH 00°22'32" EAST, 2691.68 FEET TO THE NORTHWEST CORNER OF THE NORTHEAST 1/4 OF THE NORTHWEST 1/4 OF SAID SECTION 19; THENCE NORTH 89°30'26" WEST, 1334.74 FEET ALONG THE SECTION LINE TO THE NORTHWEST CORNER OF SAID SECTION 19; THENCE NORTH 89°25'32" WEST, 2701.52 FEET ALONG THE SOUTH LINE OF SECTION 13, TOWNSHIP 6 SOUTH, RANGE 3 WEST, SALT LAKE BASE & MERIDIAN TO THE SOUTH 1/4 CORNER OF SAID SECTION 13; THENCE NORTH 00°44'00" EAST, 5331.71 FEET ALONG THE NORTH-SOUTH CENTER SECTION LINE TO THE NORTH 1/4 CORNER OF SAID SECTION 13; THENCE SOUTH 89°28'51" EAST, 2683.99 FEET ALONG THE SECTION LINE TO THE NORTHEAST CORNER OF SAID SECTION 13; THENCE SOUTH 89°25'11" EAST, 2665.87 FEET ALONG THE NORTH LINE OF SECTION 18, TOWNSHIP 6 SOUTH, RANGE 2 WEST, SALT LAKE BASE & MERIDIAN TO THE NORTH 1/4 CORNER OF SAID SECTION 18; THENCE SOUTH 89°32'03" EAST, 2670.91 FEET ALONG THE SECTION LINE TO THE POINT OF BEGINNING, CONTAINING 2,746.51 ACRES MORE OR LESS.

LESS AND EXCEPTING FROM THE ABOVE DESCRIBED LAND, THE FOLLOWING TEN PARCELS:

PARCEL 1:
A PARCEL OF LAND LYING IN THE SOUTHWEST 1/4 OF SECTION 17, TOWNSHIP 6 SOUTH, RANGE 2 WEST, SALT LAKE BASE & MERIDIAN, DESCRIBED AS FOLLOWS:

BEGINNING AT A POINT SOUTH 00°36'11" WEST, 1294.17 FEET ALONG THE SECTION LINE, AND WEST, 1687.98 FEET FROM THE CENTER 1/4 CORNER OF SECTION 17, TOWNSHIP 6 SOUTH, RANGE 2 WEST, SALT LAKE BASE & MERIDIAN; THENCE SOUTH 08°49'29" EAST, 445.60 FEET; THENCE NORTH 81°03'31" EAST, 103.41 FEET; THENCE SOUTH 08°49'29" EAST, 46.58 FEET; THENCE SOUTH 81°03'31" WEST, 237.30 FEET TO THE EASTERLY RIGHT-OF-WAY LINE OF "STATE ROUTE NO. 73"; THENCE NORTH 08°49'29" WEST, 532.18 FEET ALONG SAID RIGHT-OF-WAY LINE; THENCE LEAVING SAID RIGHT-OF-WAY LINE RUNNING NORTH 81°03'31" EAST, 133.89 FEET TO THE POINT OF BEGINNING, CONTAINING 1.84 ACRES MORE OR LESS.

EXHIBIT "A"

THAT PART OF THE NORTHEAST 1/4 OF SECTION 16, TOWNSHIP 6 SOUTH, RANGE 2 WEST, SALT LAKE BASE AND MERIDIAN, DESCRIBED AS FOLLOWS:
BEGINNING AT A POINT SOUTH 89°23'26" EAST, 75.88 FEET ALONG THE SECTION LINE FROM THE NORTH 1/4 CORNER OF SECTION 16, TOWNSHIP 6 SOUTH, RANGE 2 WEST, SALT LAKE BASE AND MERIDIAN; THENCE SOUTH 89°23'26" EAST, 200.00 FEET ALONG THE SECTION LINE; THENCE SOUTH 00°25'30" WEST, 167.32 FEET; THENCE NORTH 89°23'26" WEST, 200.00 FEET; THENCE NORTH 00°25'30" EAST, 167.32 FEET TO THE POINT OF BEGINNING.

EXHIBIT "B"

LAND LYING IN THE SOUTHWEST 1/4 OF SECTION 16, AND IN THE NORTHWEST 1/4 OF SECTION 21, TOWNSHIP 6 SOUTH, RANGE 2 WEST, SALT LAKE BASE AND MERIDIAN, DESCRIBED AS FOLLOWS:
BEGINNING AT A POINT SOUTH 89°21'43" EAST, 948.25 FEET ALONG THE SECTION LINE FROM THE SOUTHWEST CORNER OF SECTION 16, TOWNSHIP 6 SOUTH, RANGE 2 WEST, SALT LAKE BASE AND MERIDIAN; THENCE NORTH 00°37'31" EAST, 82.05 FEET; THENCE SOUTH 89°22'57" EAST, 200.00 FEET; THENCE NORTH 00°37'31" WEST, 200.00 FEET; THENCE NORTH 89°22'57" WEST, 200.00 FEET; THENCE NORTH 00°37'31" EAST, 117.94 FEET TO THE POINT OF BEGINNING.

EXHIBIT "C"

THAT PART OF THE NORTHWEST 1/4 OF SECTION 21, TOWNSHIP 6 SOUTH, RANGE 2 WEST, SALT LAKE BASE AND MERIDIAN, DESCRIBED AS FOLLOWS:
BEGINNING AT A POINT SOUTH 00°38'49" WEST, 1200.10 FEET ALONG THE SECTION LINE, AND EAST, 1011.49 FEET FROM THE NORTHWEST CORNER OF SECTION 21, TOWNSHIP 6 SOUTH, RANGE 2 WEST, SALT LAKE BASE AND MERIDIAN; THENCE SOUTH 89°22'57" EAST, 200.00 FEET; THENCE SOUTH 00°37'31" WEST, 200.00 FEET; THENCE NORTH 89°22'57" WEST, 200.00 FEET; THENCE NORTH 00°37'31" EAST, 200.00 FEET TO THE POINT OF BEGINNING.

EXHIBIT "D"

LAND LYING IN THE SOUTHWEST 1/4, AND IN THE SOUTHWEST 1/4 OF SECTION 17, TOWNSHIP 6 SOUTH, RANGE 2 WEST, SALT LAKE BASE AND MERIDIAN, DESCRIBED AS FOLLOWS:
BEGINNING AT A POINT NORTH 00°56'11" EAST, 542.32 FEET ALONG THE SECTION LINE FROM THE SOUTH 1/4 CORNER OF SECTION 17, TOWNSHIP 6 SOUTH, RANGE 2 WEST, SALT LAKE BASE AND MERIDIAN; THENCE NORTH 89°30'09" WEST, 62.80 FEET; THENCE NORTH 00°55'13" EAST, 200.00 FEET; THENCE SOUTH 89°30'09" EAST, 200.00 FEET; THENCE SOUTH 00°55'13" WEST, 200.00 FEET; THENCE NORTH 89°30'09" WEST, 137.10 FEET TO THE POINT OF BEGINNING.

EXHIBIT "E"

LAND LYING IN THE SOUTHWEST 1/4, AND IN THE SOUTHWEST 1/4 OF SECTION 17, TOWNSHIP 6 SOUTH, RANGE 2 WEST, SALT LAKE BASE AND MERIDIAN, DESCRIBED AS FOLLOWS:
BEGINNING AT A POINT NORTH 00°56'11" EAST, 81.86 FEET ALONG THE SECTION LINE FROM THE SOUTH 1/4 CORNER OF SECTION 17, TOWNSHIP 6 SOUTH, RANGE 2 WEST, SALT LAKE BASE AND MERIDIAN; THENCE NORTH 89°30'09" WEST, 63.56 FEET; THENCE NORTH 00°55'13" EAST, 200.00 FEET; THENCE SOUTH 89°30'09" EAST, 200.00 FEET; THENCE SOUTH 00°55'13" WEST, 200.00 FEET; THENCE NORTH 89°30'09" WEST, 136.44 FEET TO THE POINT OF BEGINNING.

EXHIBIT "F"

THAT PART THE SOUTHWEST 1/4 OF SECTION 17, TOWNSHIP 6 SOUTH, RANGE 2 WEST, SALT LAKE BASE AND MERIDIAN, DESCRIBED AS FOLLOWS:
BEGINNING AT A POINT ON THE EASTERLY RIGHT-OF-WAY LINE OF STATE ROUTE NO. 73, SAID POINT BEING SOUTH 89°51'20" EAST, 828.08 FEET ALONG THE SECTION LINE, AND SOUTH, 1198.02 FEET FROM THE WEST 1/4 CORNER OF SECTION 17, TOWNSHIP 6 SOUTH, RANGE 2 WEST, SALT LAKE BASE AND MERIDIAN; THENCE NORTH 08°49'29" WEST, 32.00 FEET ALONG SAID RIGHT-OF-WAY LINE; SOUTH 89°22'27" EAST, 93.14 FEET; THENCE SOUTH 89°30'31" EAST, 32.01 FEET; THENCE NORTH 89°33'32" WEST, 93.23 FEET TO THE POINT OF BEGINNING.

EXHIBIT "G"

THAT PART THE SOUTHWEST 1/4 OF SECTION 17, TOWNSHIP 6 SOUTH, RANGE 2 WEST, SALT LAKE BASE AND MERIDIAN, DESCRIBED AS FOLLOWS:
BEGINNING AT A POINT ON THE EASTERLY RIGHT-OF-WAY LINE OF STATE ROUTE NO. 73, SAID POINT BEING SOUTH 89°51'20" EAST, 805.59 FEET ALONG THE SECTION LINE, AND SOUTH, 1051.20 FEET FROM THE WEST 1/4 CORNER OF SECTION 17, TOWNSHIP 6 SOUTH, RANGE 2 WEST, SALT LAKE BASE AND MERIDIAN; THENCE NORTH 08°49'29" WEST, 28.00 FEET ALONG SAID RIGHT-OF-WAY LINE; SOUTH 89°28'00" EAST, 19.21 FEET; THENCE SOUTH 11°55'17" EAST, 25.29 FEET; THENCE NORTH 89°28'00" WEST, 21.09 FEET TO THE POINT OF BEGINNING.

EXHIBIT "H"

THAT PART THE NORTHEAST 1/4 OF SECTION 18, TOWNSHIP 6 SOUTH, RANGE 2 WEST, SALT LAKE BASE AND MERIDIAN, DESCRIBED AS FOLLOWS:
BEGINNING AT A POINT SOUTH 00°30'14" WEST, 1029.97 FEET ALONG THE SECTION LINE FROM THE NORTH 1/4 CORNER OF SECTION 18, TOWNSHIP 6 SOUTH, RANGE 2 WEST, SALT LAKE BASE AND MERIDIAN; THENCE NORTH 00°30'14" EAST, 208.00 FEET ALONG THE SECTION LINE; THENCE SOUTH 89°29'46" EAST, 210.00 FEET; THENCE SOUTH 00°30'14" WEST, 208.00 FEET; THENCE NORTH 89°29'46" WEST, 210.00 FEET TO THE POINT OF BEGINNING.

EXHIBIT "I"

LAND LYING IN THE NORTHEAST 1/4, AND IN THE SOUTHWEST 1/4 OF SECTION 13, TOWNSHIP 6 SOUTH, RANGE 3 WEST, SALT LAKE BASE AND MERIDIAN, DESCRIBED AS FOLLOWS:
BEGINNING AT A POINT NORTH 88°39'30" WEST, 1998.10 FEET ALONG THE SECTION LINE FROM THE EAST 1/4 CORNER OF SECTION 13, TOWNSHIP 6 SOUTH, RANGE 3 WEST, SALT LAKE BASE AND MERIDIAN; THENCE SOUTH, 178.23 FEET; THENCE WEST, 200.00 FEET; THENCE NORTH, 200.00 FEET; THENCE EAST, 200.00 FEET; THENCE SOUTH, 21.77 TO THE POINT OF BEGINNING.

EXHIBIT “B”

Exhibit 12 – WHWC Transition Agreement

White Hills Water Company Transition and Acquisition Agreement
with
Eagle Mountain City

The White Hills Water Company, Inc. a Utah for-profit corporation, and Eagle Mountain City, a municipal corporation of the State of Utah, for valuable consideration, enter into this White Hills Water Company Transition and Acquisition Agreement with Eagle Mountain City ("Agreement") this 19 day of JANUARY, 2000, and agree as follows:

RECITALS

Parties. White Hills Water Company, Inc., a Utah for-profit corporation owns and operates the culinary water system for the White Hills Subdivision located in Cedar Valley in unincorporated Utah County. White Hills Water Company, Inc. is a "C-Corporation and is owned by Cedar Valley Water, LLC, which is owned by Oquirrh Wood Holdings, LLC ("WHWC"). Eagle Mountain City is a municipal corporation of the State of Utah ("City").

Annexation. Certain real properties owned by, Oquirrh Wood Ranch, LLC, and others as identified in the draft "Annexation and Pole Canyon Master Development Agreement" have petitioned Eagle Mountain City for annexation. Located within the boundaries of the property under consideration for annexation is the White Hills Water Company, Inc.

White Hills Water Company, Inc. WHWC is currently a water utility regulated by the Utah Public Service Commission to provide service to the White Hills Subdivision in Utah County, Utah. WHWC owns certain assets of real property, culinary and irrigation water rights, and water system infrastructure and equipment, including but not limited to wells, pump houses, storage tank(s), pipelines, valves, fire hydrants, water system capacity, and other assets as more fully described in Exhibit A, except the irrigation water rights which are more fully described in Exhibit B. WHWC also owns certain cash, account receivables and other financial assets as more fully described in Exhibit C. WHWC is a party to certain Agreements, Contracts, Insurance Policies and other written instruments as more fully described in Exhibit D.

Transition of WHWC Ownership and Operation. After completion of the annexation, the parties desire to transfer the ownership and operation of the WHWC culinary water system and other assets to Eagle Mountain City after the required improvements have been completed. The required improvements must be completed before any part of the Project within Oquirrh Wood Ranch receives a building permit

from the City. WHWC has completed a number of upgrades to the system and infrastructure, and shall perform additional upgrades before the City accepts and operates the water system. The terms and conditions of the transfer, transition and acquisition are as set forth below.

AGREEMENT

1. The transfer from WHWC and acquisition of assets by the City shall occur by WHWC donating, transferring and conveying or assigning the specific assets listed on Exhibit A to the City. The balance of the assets not a part of the existing system, required to provide water service which are described in Exhibit B shall be transferred as directed in Paragraph 8, below. No transfer of stock in WHWC to the City shall occur, however, the stock certificates representing all of the outstanding shares in WHWC shall be delivered to the City to insure that the owners of shares in WHWC comply with the transfer of ownership restrictions of this Agreement. The parties agree that the transition and acquisition shall be conducted to mutually benefit the parties.

- a. After the approval and effective date of the Annexation described in Paragraph 2 above, WHWC shall retain ownership, operation and control of the water system serving the White Hills Subdivision and shall complete the improvements and repairs described in this Agreement prior to the First Closing. The First Closing shall occur before any part of the Oquirrh Wood Ranch Project receives a building permit from the City, but not later than on or before January 1, 2011. The sole remedy for not completing the required improvements and the First Closing on or before January 1, 2011, shall be that no building permits may be issued by the City until the First Closing occurs. WHWC shall cause engineered plans and specifications to be prepared for the required improvements and shall submit the plans to the City for review, comment and approval before work commences after the date of this Agreement. To accommodate City inspection of construction, notice shall be provided to the office of the City Engineer, to the person designated by the City, of selection of the proposed contractor or equipment vendor, including copies of all relevant materials describing the work, and all pre construction meetings and other activities as requested by the City during the course of construction.
- b. As security for the completion of the improvements and repairs required by this Agreement, WHWC shall deliver to the City the stock certificates representing their ownership interest in the WHWC. The City shall hold the WHWC stock certificates required by this Agreement in its possession until

a final release letter is issued by the City to WHWC when all the required repairs or improvements are completed, inspected and approved by the City, whereupon the stock certificates shall be returned to WHWC.

- c. During the period between Annexation and the First Closing when the WHWC water system for the White Hills Subdivision assets described in Exhibit A are donated, transferred, and conveyed or assigned to the City, WHWC covenants not to:
- (1) encumber the stock or other assets of WHWC;
 - (2) transfer ownership of any asset of WHWC, except that WHWC may convey and sell portions of the irrigation water rights;
 - (3) extend water service beyond those existing or prepaid water connections;
 - (4) exercise the power of eminent domain.

2. Transition Actions.

- a. Prior to transfer of the water system to the City and either before or after this Agreement is executed, and subject to the review and approval of all improvements by the City Engineer, WHWC or others shall improve the water system, after approval of all plans and specifications for improvements and with provision for ongoing inspection of the work in progress by the City, as follows:
- (1) Chlorinate and flush the One Million Gallon Storage Tank and upper pipeline, and begin storing water in the tank in compliance with state regulations, in preparation to service the Cook Well;
 - (2) Upgrade the Cook Well by installing a completely new pump system, including pump, pump column, and pump motor, downhole transducer, pitless adapter, drawdown sensor, and flow meter, as more fully defined in the recommendation of the City Engineer;
 - (3) Provide the City water quality sampling data for the WHWC water system. Chlorination equipment will be added if water samples require chlorination;
 - (4) Provide copies of any water system as built drawing(s), survey(s) and/or legal description of the well site(s) to be dedicated to the City;
 - (5) Retain Corrosion Control Technologies (or another similar company) to evaluate the water storage tanks and make recommendations for a plan to maintain, improve and/or upgrade the existing storage tanks, including re-painting, and ultimately re-lining the storage tanks;

- (6) Construct an additional state-approved Drinking Water Well, (16-inch diameter, approximately 350 feet deep, estimated to produce a sustainable yield of at least 1200 gpm). The new well shall be in close proximity to the Cook Well. The City and WHWC shall cooperatively file a temporary change application for the well based on WHWC water rights. Ultimately, a permanent change application adding the new well will be filed (\$240,000 estimate).
- (7) Construct a new Control House to serve both the existing Cook Well and the New Well, including any and all electrical panels and controls, valves automation equipment, chlorination equipment, if necessary. At the time the new Control House is constructed, a new soft starter will be installed.
- (8) Re-paint storage tanks.
- (9) Replace all the manual read meters with electronic read meters. The electronic read meters will be installed by the City.
- (10) Take action(s) to maintain and/or upgrade the storage tanks and to extend their useful life and/or increase their capacity, pursuant to plan(s) developed based on Corrosion Control Technologies' recommendations, including but not limited to providing inner relining as recommended. In exchange for any and all improvements to the storage tanks not paid for by the City, OWR/PCIG shall have impact fee credits for extending the storage capacity life as set forth in paragraph 15.

3. First Closing. At the First Closing WHWC shall donate, transfer and convey or assign to the City the assets of WHWC described below and which are more fully described in Exhibit A without encumbrance or reservation or condition:

- a. Real Property. Improved Real Property, as more specifically described in the attached Exhibit A, consisting of several parcels of property where wells and tanks, etc. are located, will be conveyed by Special Warranty Deed free and clear of all encumbrances including delinquent or pending property taxes or other financial encumbrances. Such conveyances will include all water system improvements and infrastructure used or constructed to be used in providing water service to the White Hills Subdivision wherever located but located on such property, including but not limited to wells, pump houses, storage tanks, pipelines, etc.
- b. Easements. Easements, as more fully described in the attached Exhibit A, for existing and future waterlines shall be conveyed by assignment and/or appropriate deed with warranty of transferability and status in good

standing. The parties specifically agree that to the extent pipelines are moved in the future, and existing easements are no longer needed, such easements will be abandoned, relinquished and reconveyed to the Grantor(s) or neighboring property owners as directed by WHWC.

- c. Culinary Water System Water Rights. Water rights, as more fully described in the attached Exhibit A, consisting of water rights that have already been approved for culinary and domestic use, shall be conveyed by Special Warranty Water Rights Deed(s).
- d. Water System Improvements, Infrastructure and Equipment. The vast majority of the water system improvements and infrastructure improvements are attached to real property that will be conveyed by deed, as set forth above. To the extent any water system infrastructure or equipment is personal property not attached to real property to be conveyed, it will be assigned and/or conveyed via appropriate Bill of Sale.
- e. Financial Assets
 - (1) Accounts Receivable and Payable. Accounts receivable and payable for the WHWC shall be closed as of the First Closing date. The parties agree that accounts receivable due and owing to WHWC are to include water usage billings, standby fees, and other customer reimbursables invoiced by WHWC after closing for water usage or services rendered prior to closing. No cash will be transferred to the City except as expressly provided otherwise in this Agreement. The parties agree that accounts payable by WHWC are to include employee wages, salary and payroll taxes and expenses if any, invoices for contractors, suppliers and electric utilities invoiced after the closing for purchases and services of every kind provided prior to closing. The City will not assume any liability of the WHWC and the WHWC represents that at closing it will have no liability for any other payables not expressly stated in this paragraph.
 - (2) Impact Fees. There are no Impact Fees or related fees collected by WHWC that have not previously been spent for appropriate improvements or operations. Therefore, no impact fees will be transferred to the City upon transfer of the water system improvements.

4. Second and Subsequent Closing(s) on the one year anniversary date and subsequent one year intervals. One year from the date of the first closing and or on each subsequent anniversary date thereafter, as necessary, WHWC at its sole discretion may donate, convey and assign to the City any, all, or no portion of the remaining assets as determined by WHWC, including portions of the Irrigation Water Rights described in Exhibit B and any associated change applications. The conveyance shall be by a Special Warranty Water Rights Deed, the form of which is attached as Exhibit F acceptable to counsel for the City. The transfer of any Irrigation Water Rights to the City shall be with the express reservation of WHWC to use the water for irrigation on the heretofore lands authorized to be irrigated under the water rights until such time that the City requires the water for municipal purposes.

5. Change Application.

- a. The WHWC may file a change application with the State Engineer to change the nature of use, place of use and points of diversion for some or all of the Culinary and Irrigation Water Rights to be used for municipal purposes within the service area of the City prior to the First Closing. A copy of the change application (if filed with the State Engineer) is attached as Exhibit G.
- b. If the change application is not filed as of the date of this Agreement, WHWC and the City shall work cooperatively in preparing and filing the change application to identify the proper points of diversion for the hereafter wells. All the existing points of diversion for the Water Rights shall continue as authorized wells under the change application in addition to City wells identified by the City.
- c. WHWC shall be responsible for all costs associated with, and for obtaining approval of, the change application. The City shall cooperate with WHWC in obtaining approval.
- d. Until the Water Rights are needed by the City to service the Oquirrh Wood Ranch and the Pole Canyon Project, Oquirrh Wood Ranch shall have the right to continue to put the water under the Water Rights to full beneficial use, including irrigation, stockwater and other agricultural uses at the sole cost and expense of Oquirrh Wood Ranch utilizing sources and wells not owned by the City or used in the operation of the water system.

- e. The filing of the change application shall not prevent WHWC or assigns to sell at their sole discretion portions or all of the Irrigation Water Rights to third parties.
- f. The timing of when the Culinary Water Rights will be conveyed to the City, and when and if the Irrigation Water Rights will be conveyed to the City, and the quantity of the Culinary and Irrigation Water Rights conveyed to the City shall be in accordance with the terms of this Agreement.

6. Transfer of Management and Operation of Water System. At the First Closing, the City shall accept the described assets, and thereafter shall assume responsibility for operation of the water system, including delivery of culinary water to White Hills Residents, as well as for all future development in the Pole Canyon Project. The said transfer is not an exaction subject to challenge by WHWC or others.

7. Due Diligence and Inspection Period. Upon the effective date of this Agreement the City shall have a 30-day due diligence period with full inspection rights to evaluate and inspect each of the identified groups of assets.

8. Representations or Warranties. WHWC represents and warrants to the City that (i) WHWC has good and marketable title to the assets transferred to the City pursuant to this Agreement, free and clear of any lien or encumbrance, (ii) WHWC is duly authorized to enter into this transaction with the City and to consummate the transactions contemplated hereby, (iii) WHWC has obtained all governmental and/or third party consents and approvals required to consummate the transactions contemplated by this Agreement, (iv) the transactions contemplated by this Agreement do not violate any federal, state or local laws or ordinances, and (v) to the knowledge of the officers of WHWC, and except as otherwise disclosed to the City by an inspection report or other report delivered by WHWC to the City prior to the date of this Agreement, the assets transferred pursuant to this Agreement are in good condition and repair, ordinary wear and tear excepted. Except as specified in this section, any transfer under this Agreement shall be on an "As Is Where Is" basis with all faults and defects that may exist now and in the future, without representations or warranties by WHWC. The foregoing representations and warranties provided by this Agreement shall continue for a period of one year following the date of when each portion of the water system is acquired, including the wells, water tanks, water, distribution systems and the other portions of the water system. Also, any manufacturer, contractor or other third party warranty granted in favor of WHWC will survive this Agreement for the full period of the warranty, and are hereby assigned to the City.

9. Public Service Commission. The culinary water service provided by WHWC to the White Hills Subdivision is regulated as a water utility by the Utah Public Service Commission ("PSC"). Upon transfer of the assets and operation of the WHWC to the City, the parties agree that the PSC shall have no further jurisdiction and regulatory authority over the assets, rates and operation of the water system. WHWC shall meet any PSC requirements and upon transfer of the operation of the WHWC to the City, WHWC shall obtain an acknowledgment from the PSC that the water system is no longer regulated as a public water utility.

10. Water Rights Banking. The parties expressly agree that any and all water rights conveyed to the City in excess of those water rights necessary to serve the existing White Hills Subdivision will be accepted and banked by the City for the use and benefit of Oquirrh Wood Ranch, LLC ("OWR"), pursuant to the City's applicable water banking ordinance.

11. Estimated Excess Water System Capacity ERUs. In addition to excess water rights, the parties acknowledge that the donated water system has and will have a substantial amount of excess water storage, water source, and water distribution system capacities. The culinary water system currently serves 121 residential connections and includes two (2) banked or future connections. Based on an engineering analysis of the existing water system capacity conducted by Aqua Engineers and reviewed by the city's engineers (Horrocks), and depending on the condition of the assets there may be an estimated excess water system capacity beyond existing demands of the system. Excess capacity will be evaluated in the preparation of the Capital Facilities Plan for impact fee analysis to be prepared by the City. The amount and value of any excess capacity in the system shall be determined by the engineering analysis in the Capital Facilities Plan and the impact fees laws of the State of Utah. The parties acknowledge that WHWC has undertaken or will undertake substantial system upgrades and improvements after the Aqua/Horrocks studies were completed, and any assessment and credit given for excess capacities should factor these additional system upgrades and improvements into the equation for calculating excess capacity credits.

12. Credits or Reimbursement for Water System Capacity. The City agrees that WHWC may assign such rights to impact fee credit or reimbursement for excess capacity, if any, held by WHWC at the date of the final closing to the property owner entitled thereto as permitted under the terms of the impact fee law of the State of Utah.

13. Pole Canyon Basic Local District and Central Water Project Water. The Pole Canyon Basic Local District ("PCBLD") has requested from the Central Utah Water Conservancy District an allocation of at least 5,500 acre-feet of water from the Central Water Project ("CWP Water"). The parties to this Agreement anticipate that the CWP

Water will ultimately be allocated to the City for the benefit of the Pole Canyon Project and others. The delivery of the CWP Water to the Pole Canyon Project would require the construction of a pipeline to deliver water to the west side of the City where the Pole Canyon Project is located. The existing WHWC water system infrastructure is located at the base of the Pole Canyon Project. The City agrees that before any pipeline is constructed for the delivery of CWP water to the west side of the City that the City shall study and consider whether or not it is more or less cost effective to construct a pipeline to deliver CWP water to the Pole Canyon project, expand and develop the sources under the ownership and control of the WHWC, or it's successor's in interest, or provide water by exchange using the CWP contract water to provide water to other areas of the City.

14. Mutual Indemnification. WHWC indemnifies the City for the time period the water system was owned and operated by WHWC, and the City indemnifies WHWC beginning on ____ [date] _____ when the City owns and operates the water system.

15. Alternative Dispute Resolution, Legal Action & Attorneys Fees. In the event any dispute(s) should arise between the parties, based on this Agreement or their actions pursuant to this Agreement, they expressly agree to employ their best efforts to resolve any and all such dispute(s) by good-faith negotiations between themselves. In the event they are unsuccessful in reaching a satisfactory resolution, however, they expressly agree to solicit the assistance of a qualified, neutral, independent, third party mediator, to assist in mediating and resolving any such dispute(s). Only in the event such efforts at alternative dispute resolution are unsuccessful will the parties resort to litigation as a means of attempting to resolve any such disputes, in which case the prevailing part(ies) shall be entitled to recover from the other all of their costs and reasonable attorneys fees incurred in connection with any such action(s). Otherwise, the parties shall each be responsible for their own attorneys fees associated with this transaction, including preparation and review of documents to support it.

16. Miscellaneous Provisions.

- a. The parties expressly agree to execute any and all other documents and instruments, and to take any and all other actions as may be necessary to carry out the express intentions of the parties, and shall use their good faith and diligent efforts to accomplish, close and fully consummate the transaction contemplated by this Agreement.
- b. In the event any of the terms, conditions or covenants contained in this Agreement are held to be invalid, any such invalidity shall not affect any other term or condition contained herein, and the remaining valid portion(s) of the

Agreement shall remain in full force and effect.

- c. This Agreement and all terms, conditions, rights, entitlements and obligations hereof shall survive the Closing, and not be deemed merged and/or terminated at Closing.
- d. This Agreement supersedes any and all previous agreements, written or verbal, by and between the parties, and any and all such agreements are deemed merged herein. No modification of this Agreement shall be enforceable unless such modification is in writing, signed by the parties affected by the modification. This Agreement may be executed in any number of counterparts; and when so executed, all of such counterparts shall constitute a single instrument binding upon all parties hereto, notwithstanding the fact that all parties are not signatory to the original or to the same counterpart.

WHITE HILLS WATER COMPANY, INC.

By:  Nathan Shipp

Its: President

STATE OF UTAH)

ss.

COUNTY OF UTAH)

On the 20th of January, ~~2009~~²⁰¹⁰ personally appeared before me, Nathan Shipp who duly acknowledged to me that the foregoing instrument was executed on behalf of WHITE HILLS WATER COMPANY, INC.

My Commission Expires: 10-20-2013

Julie A. Hirsch
Notary Public

Residing at: Salt Lake Co

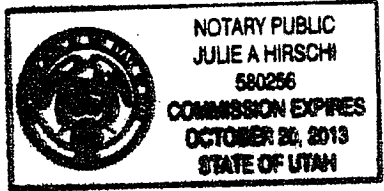

CEDAR VALLEY WATER, LLC

By: Nathan Shipp

Its: Manager

STATE OF UTAH)

ss.

COUNTY OF UTAH)

On the 20th of January, ~~2009~~ ²⁰¹⁰ personally appeared before me, Nathan Shipp who duly acknowledged to me that the foregoing instrument was executed on behalf of CEDAR VALLEY WATER, LLC

My Commission Expires: 10-20-2013 Julie A. Hirschi
Notary Public

Residing at: Salt Lake Co.

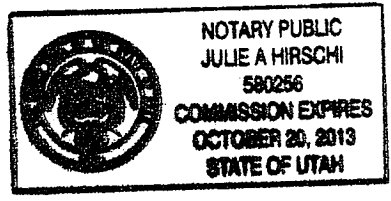

EAGLE MOUNTAIN CITY

By: Leah Jacobs
Its: Mayor

ATTEST:

Fionnuala B. Kofoed
Fionnuala B. Kofoed, City Recorder



EXHIBIT A

LIST OF ASSETS OF WHITE HILLS WATER COMPANY, INC.

Real Property and Easements

Improved real property consisting of several parcels of property where wells and tanks and other water system improvements are located and easements for existing and future pipelines and other water system improvements where the land is not owned by WHWC. Legal descriptions will be written after the properties are surveyed by a certified land surveyor. WHWC will pay all of the costs of the survey, preparation of description and cost of survey plats showing the properties in which the WHWC has title to the land or easement or other right of use.

Culinary Water Rights

Sufficient water rights to provide culinary and irrigation water to cover existing demands and uses within the White Hills Subdivision. The sufficient water rights shall be calculated using the City required standards for service. At least the 404 domestic uses as a portion of Water Right No. 54-36 and a portion of approved change application number a15643 shall be donated and conveyed.

Water System

Wells and pump houses:

- Cook Well or Primary Well, fully equipped, including but not limited to, pump, casing, piping, electrical connections, electronic controls, and upgraded well house.
- Backup Well or Cook Well, fully equipped, including but not limited to, pump, casing piping, electrical connections, electronic controls, and pump house
- Booster Pump(s), fully equipped, including but not limited to, pumps, piping, electrical connections, electronic controls, and upgraded pump house.

Water treatment facilities and equipment

Storage Tank(s)

- One (1) fully installed, equipped and connected 1,000,000 gallon water storage tank
- One (1) fully installed, equipped and connected 550,000 gallon water storage tank
- One (1) fully installed, equipped and connected 220,000 gallon water storage tank

Water distribution pipelines
Valves, fire hydrants, etc.

Vehicles. Equipment. Furniture

Exhibit B

**White Hills Water Company Transition and Acquisition Agreement
with Eagle Mountain City
January 19, 2010**

White Hills Water Company Irrigation Water Rights

| Water Right No. |
|------------------------|
| 54-34 |
| 54-37 |
| 54-77 |
| 54-80 |
| 54-1267 |
| 54-1268 |

EXHIBIT C

**FINANCIAL INFORMATION OF
WHITE HILLS WATER COMPANY, INC.
as determined under Paragraph 3.e. to be provided
at First Closing**

EXHIBIT D

AGREEMENTS, INSURANCE POLICIES AND OTHER WRITTEN INSTRUMENTS

- General liability insurance policy
- Commitments to provide a total of 131 water connections in the White Hills Water Company water system broken down as follows:
 - 121 existing connections
 - 2 prepaid connections
 - 8 committed connections for 8 vacant lots in White Hills

EXHIBIT F

SAMPLE WATER RIGHT DEED

WHEN RECORDED, RETURN TO:

Gerald H. Kinghorn
PARSONS KINGHORN HARRIS
A PROFESSIONAL CORPORATION
111 E. Broadway, 11th Floor
Salt Lake City, Utah 84111

WATER RIGHT DEED

_____, Grantor, hereby conveys and warrants to EAGLE MOUNTAIN CITY, a municipal corporation, Grantee, of 1650 E. Stagecoach Run, Utah County, Utah 84005, for TEN DOLLARS (\$10.00) and other valuable consideration the following described water right registered in the Office of the State Engineer of the State of Utah as follows:

Water Right Number: _____
Change Application Number: _____
Quantity in Acre Feet: _____ acre feet

IN WITNESS WHEREOF, the Grantor has executed this Deed the _____ day of _____, 2010.

GRANTOR:

By: _____

STATE OF UTAH)
)ss.
COUNTY OF _____)

ACKNOWLEDGMENT

On this _____ day of _____, 2010 personally appeared before me _____ who acknowledged to me that he executed the foregoing document on behalf of the Grantor.

My Commission Expiration: _____
Notary Public

EXHIBIT G

CHANGE APPLICATION

No change application has yet been filed with the State Engineer,
but a change application will be prepared pursuant to
the provisions of paragraph 9.

Exhibit 13 – Additional Exhibits/Maps

- 13.1 Circulation Plan**
- 13.2 Site Conditions**
- 13.3 Animal Rights Areas**
- 13.4 Entry Monuments**
- 13.5 Fire Access Plan**
- 13.6 Zone Classification Map (Wildland Interface Code)**
- 13.7 Soil Data**
- 13.8 White Hills Park**
- 13.9 Eagle Mountain Rodeo Grounds at Pole Canyon
(3 renderings)**
- 13.10 Equestrian Trail Cross-sections**
- 13.11 ATV Trail Cross-sections**
- 13.12 Development Process**

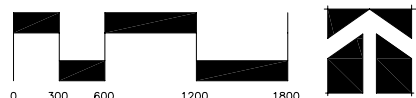
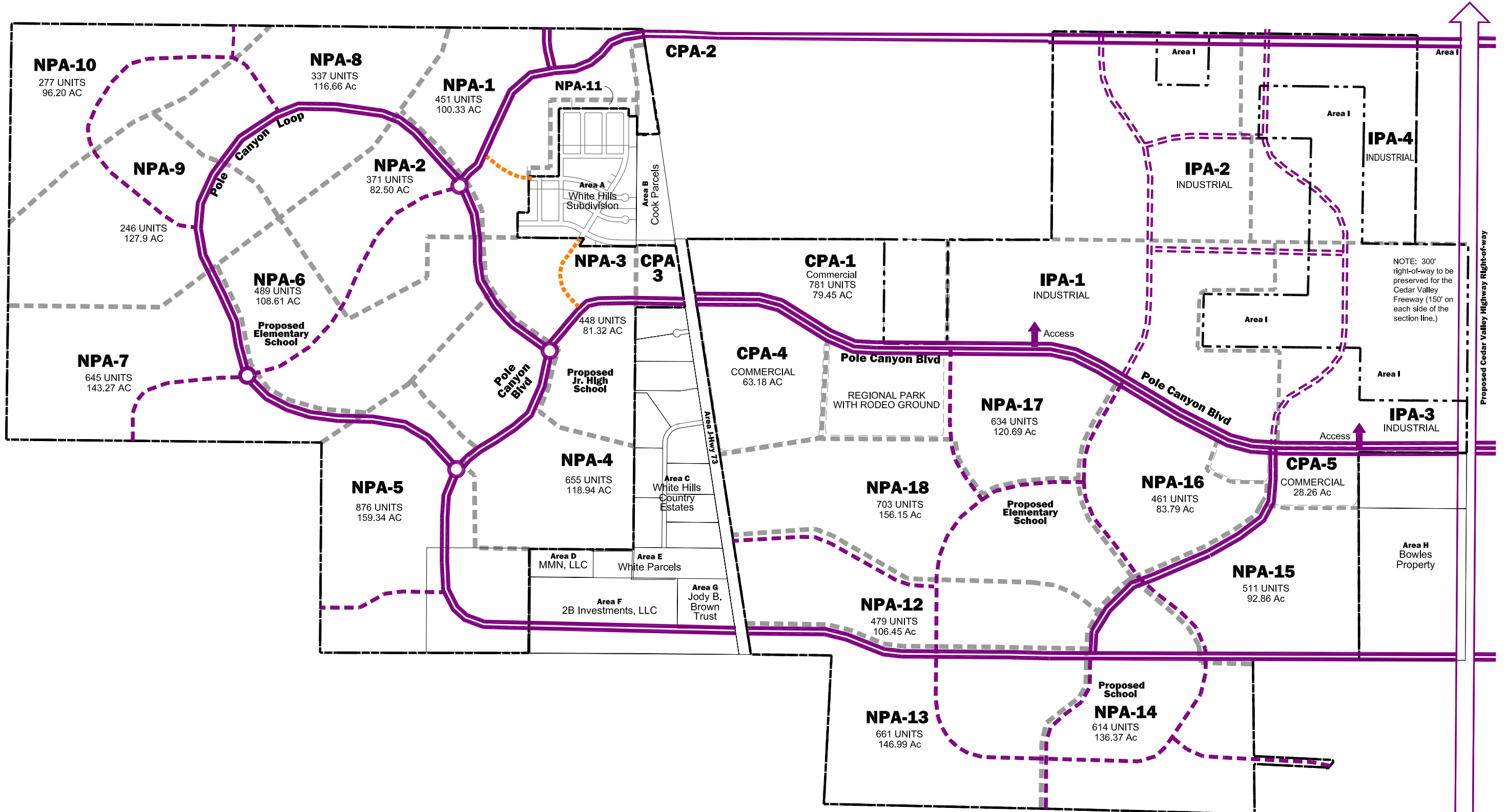

Circulation Plan Exhibit 13.1



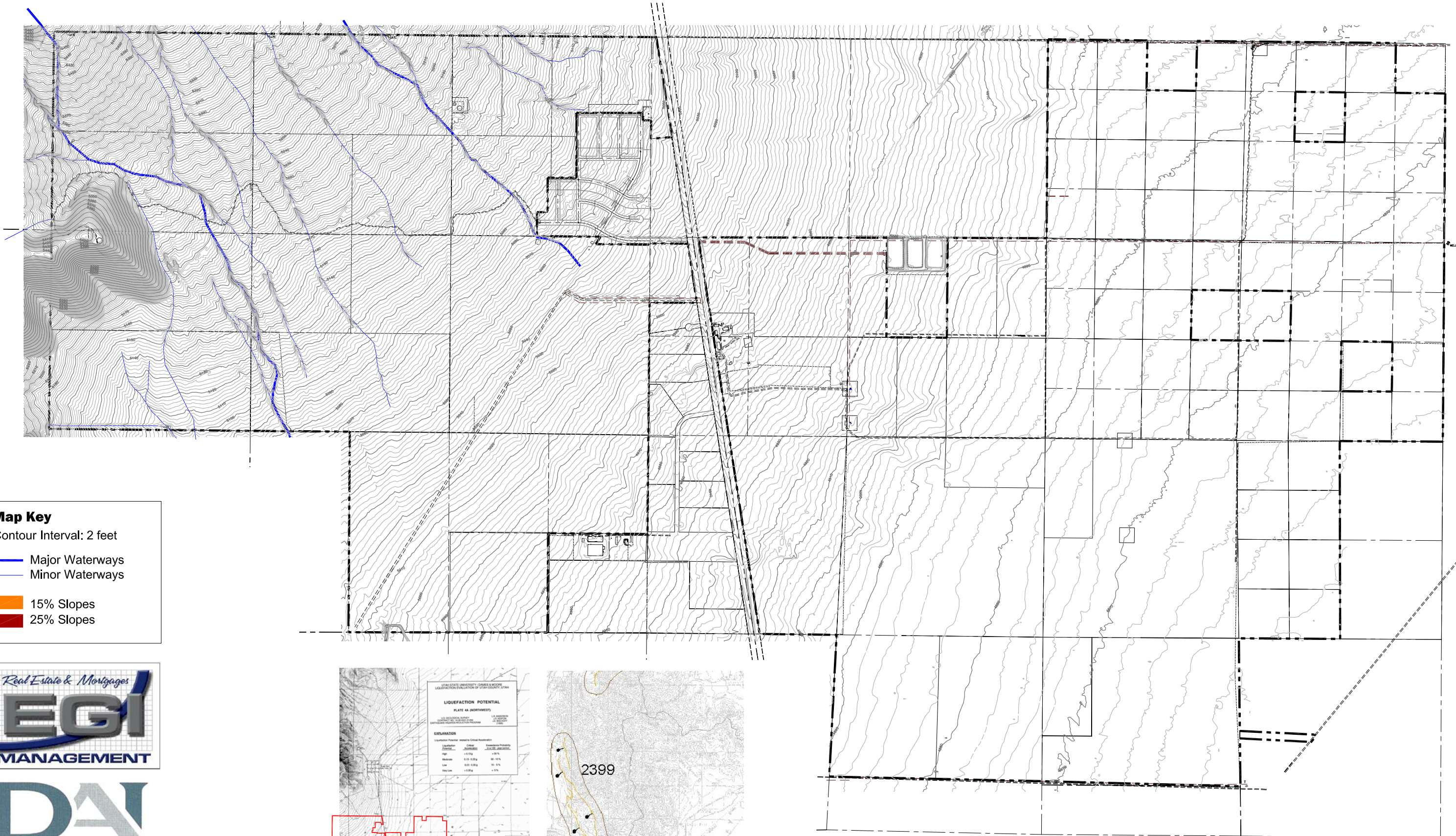

Map Key
 Contour Interval: 2 feet

- Major Waterways
- Minor Waterways
- 15% Slopes
- 25% Slopes

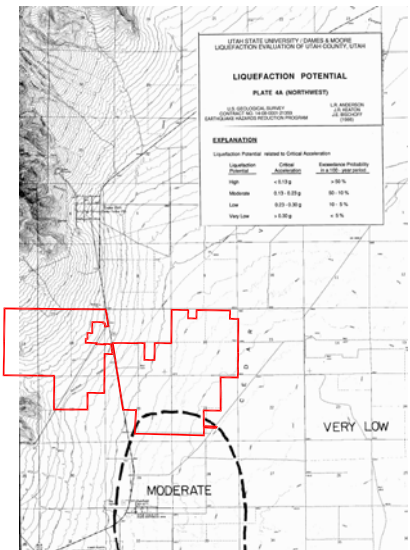
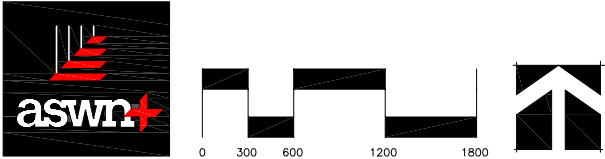

Liquefaction Potential
 Very Low to Moderate

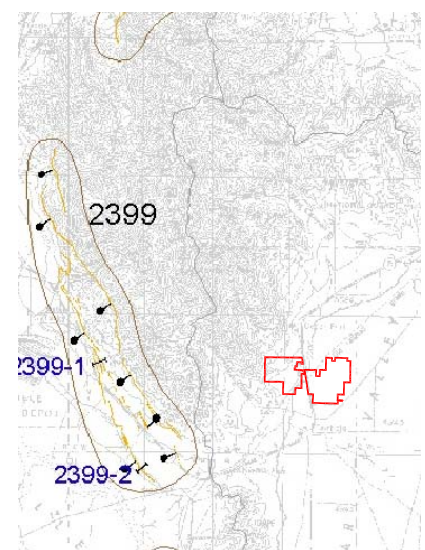

Major Faults
 None

Site Conditions

Exhibit 13.2

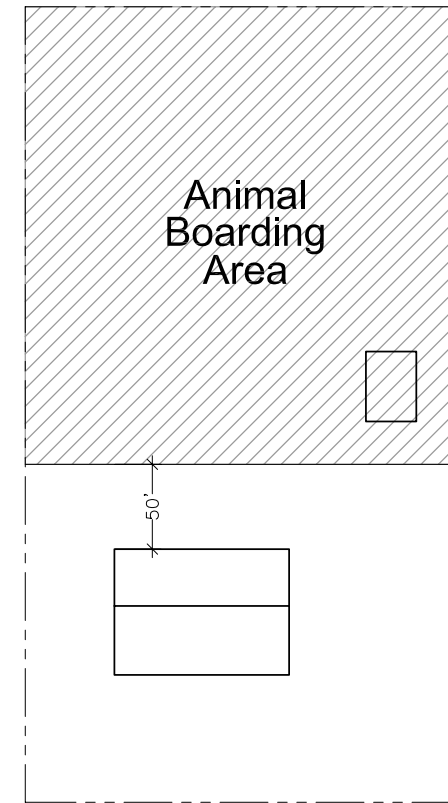
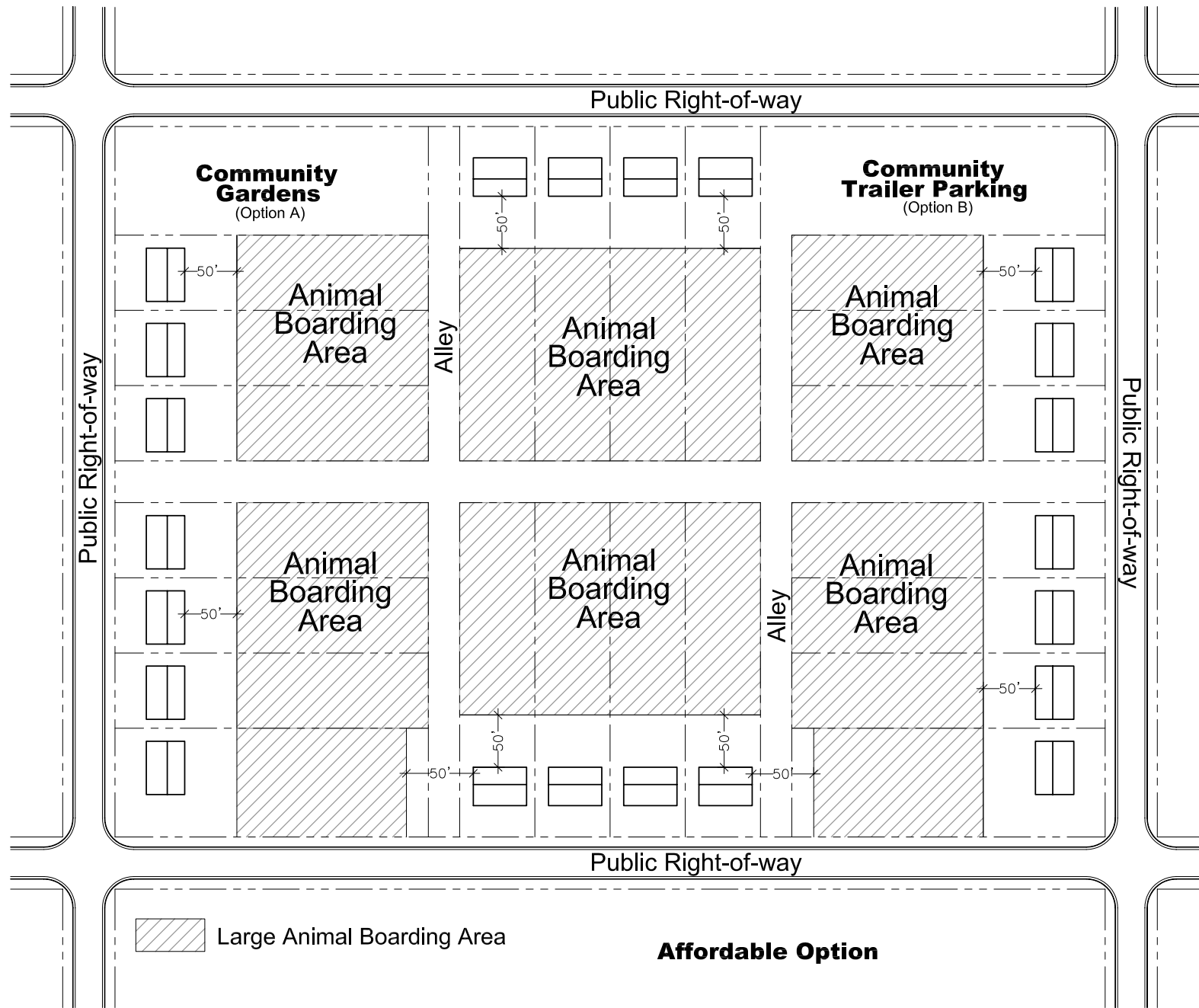

Typical 1/2-acre Lot

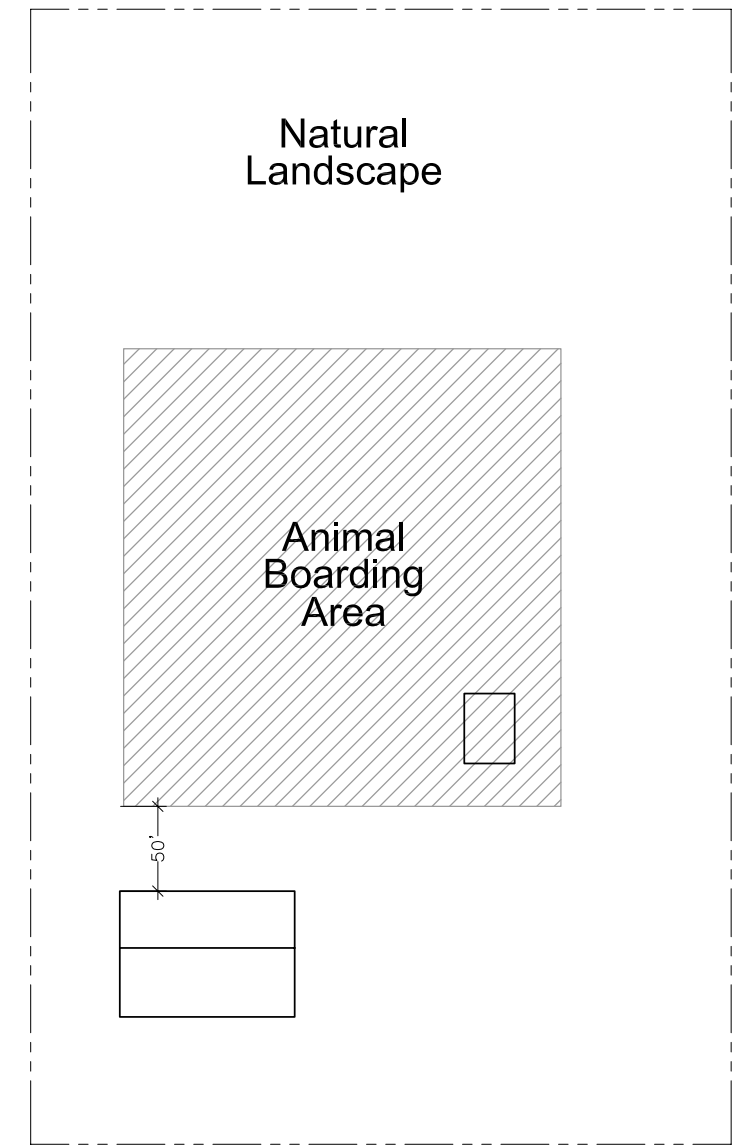

Typical 2+ acre Lot

Other Options

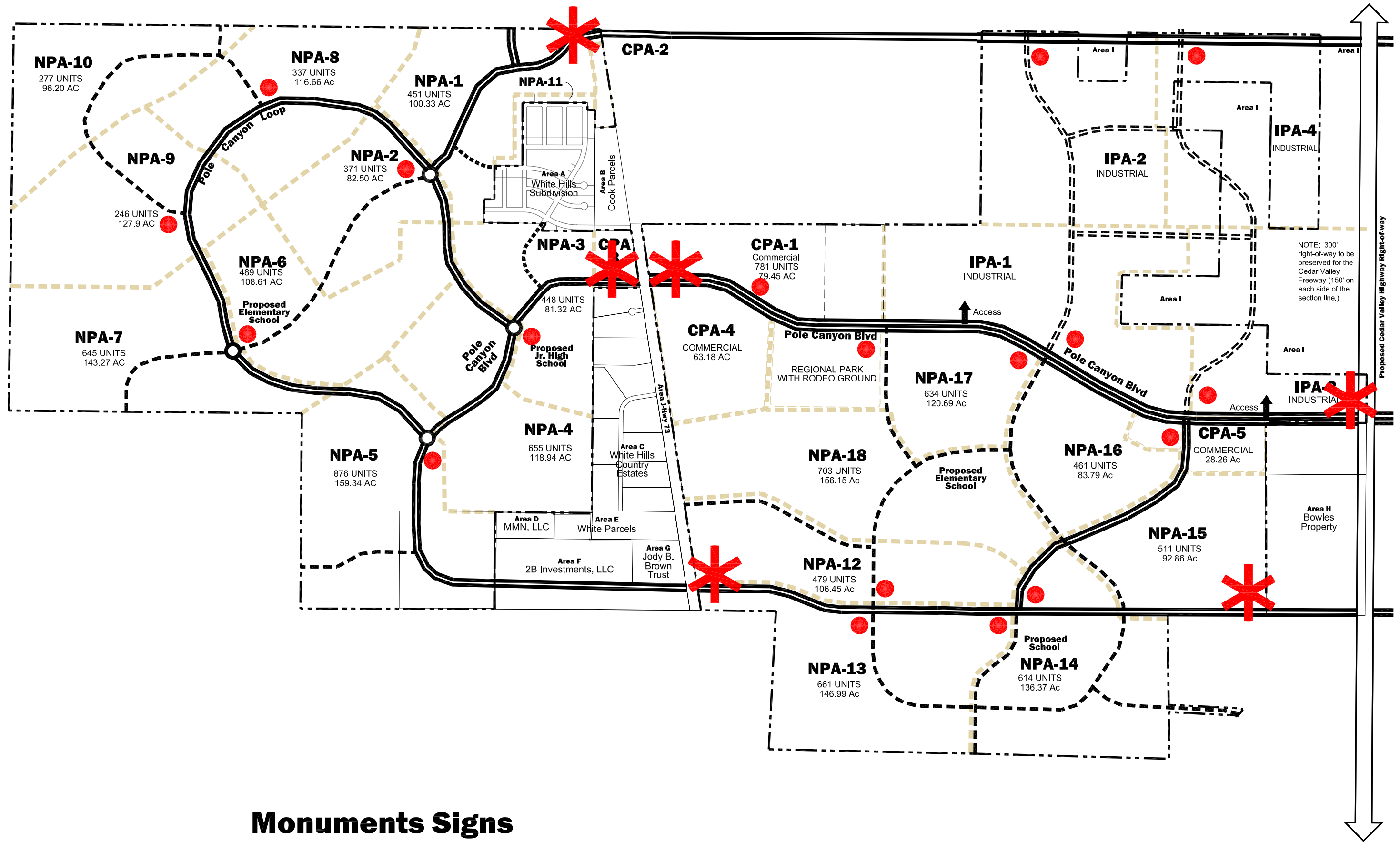

Monuments Signs

-  Major Project Monuments
-  Planning Area Monuments
(Locations may vary based on submitted concept plan)

Entry Monuments Exhibit 13.4



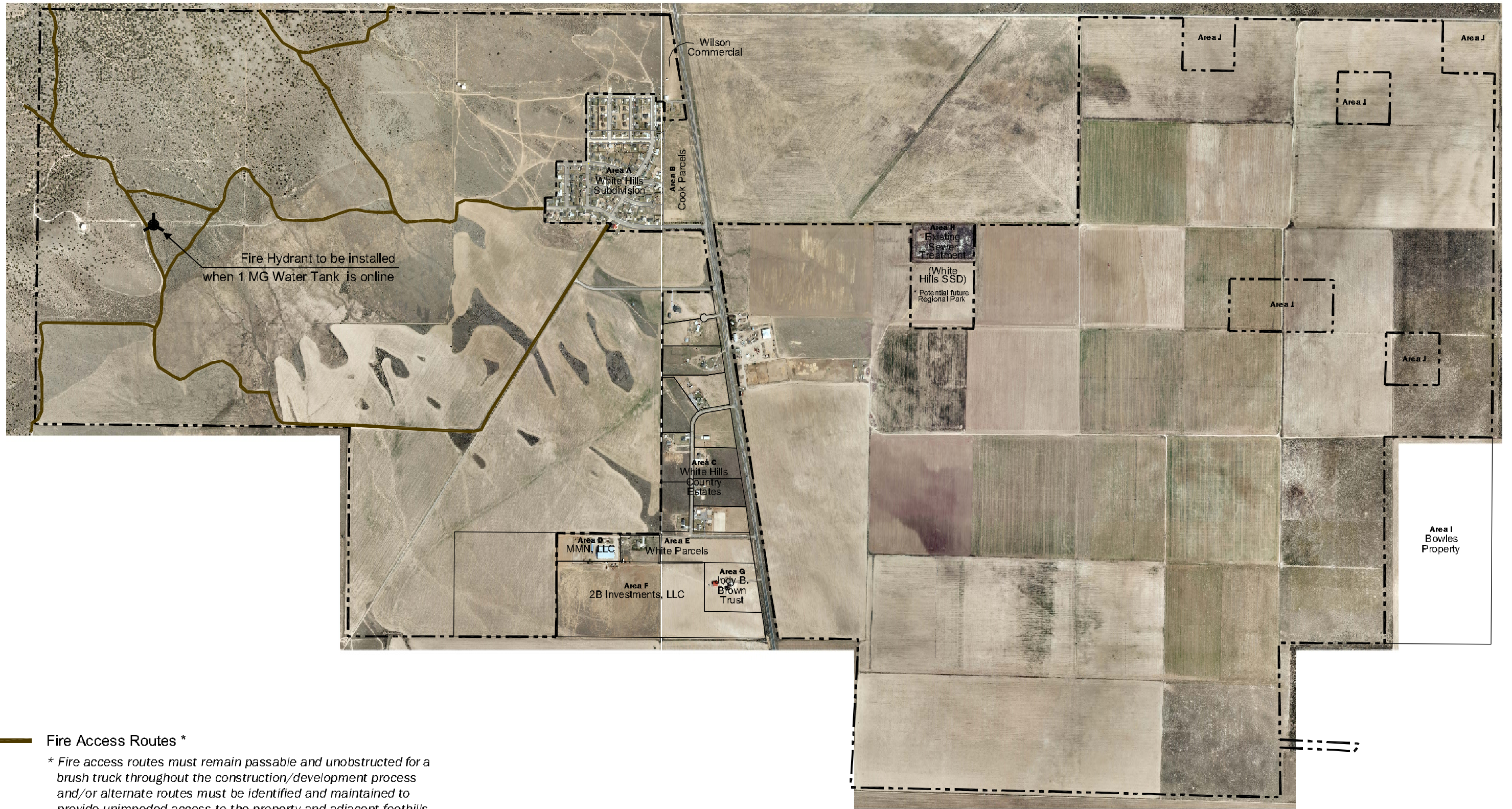

— Fire Access Routes *

* Fire access routes must remain passable and unobstructed for a brush truck throughout the construction/development process and/or alternate routes must be identified and maintained to provide unimpeded access to the property and adjacent foothills. Where fire access routes pass through agricultural areas where fences are needed, gates must be installed and maintained so that fire personnel may maintain continuous access through the property.

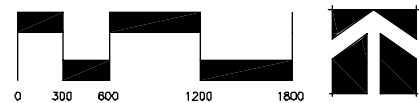



Fire Access Plan

Exhibit 13.5

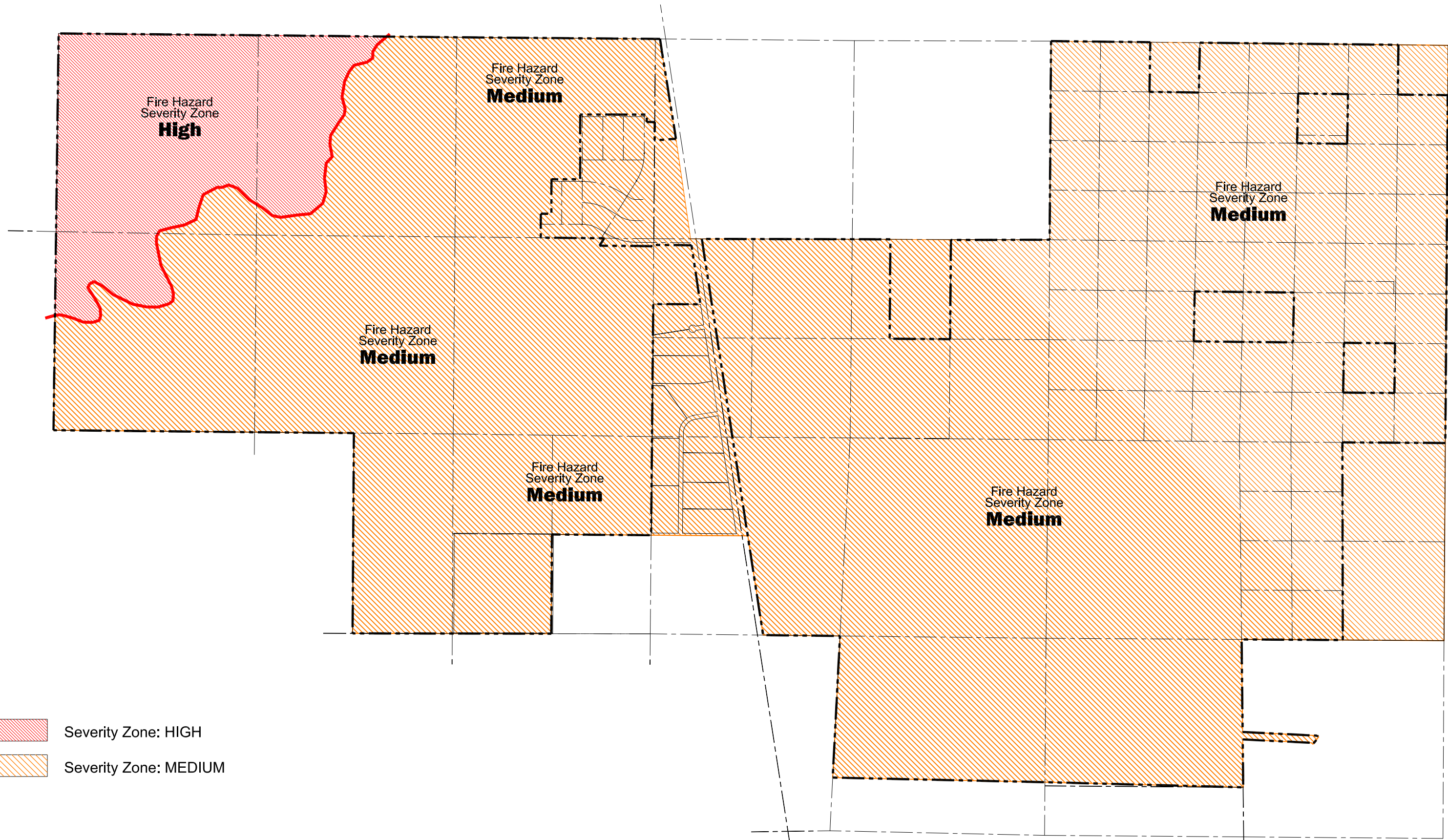



-  Severity Zone: HIGH
-  Severity Zone: MEDIUM

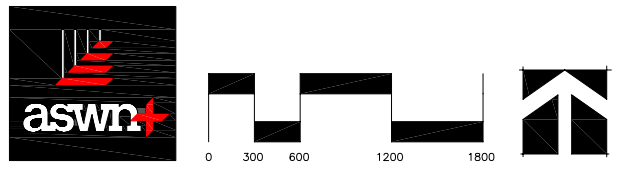

Zone Classification Map

Wildland Interface Code

Exhibit 13.6



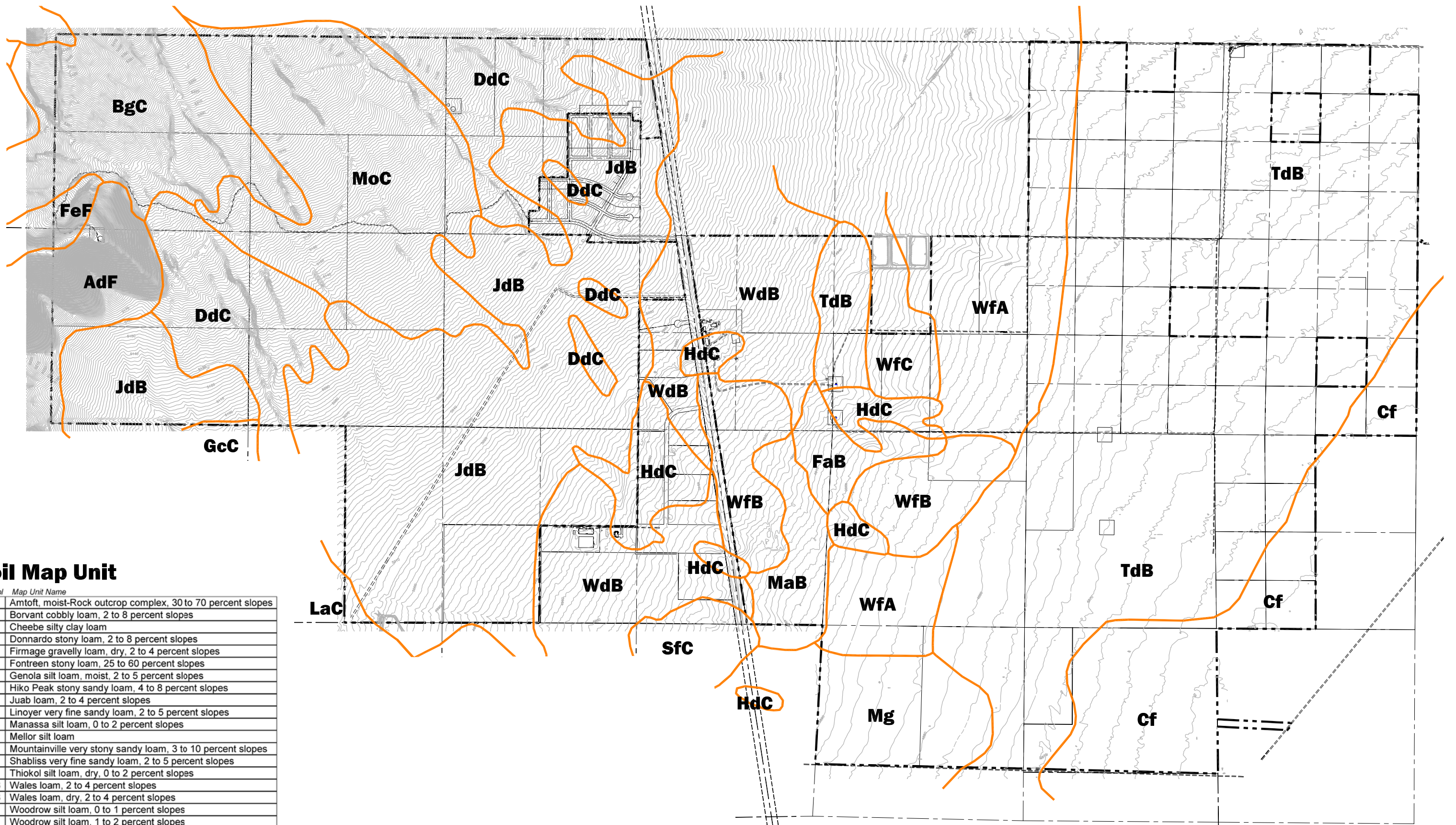

Soil Map Unit

| Symbol | Map Unit Name |
|--------|-------------------------------------------------------------|
| AdF | Amtoft, moist-Rock outcrop complex, 30 to 70 percent slopes |
| BgC | Borvant cobbly loam, 2 to 8 percent slopes |
| Cf | Cheebe silty clay loam |
| DdC | Donnardo stony loam, 2 to 8 percent slopes |
| FaB | Firmage gravelly loam, dry, 2 to 4 percent slopes |
| FeF | Fontreen stony loam, 25 to 60 percent slopes |
| GcC | Genola silt loam, moist, 2 to 5 percent slopes |
| HdC | Hiko Peak stony sandy loam, 4 to 8 percent slopes |
| JbB | Juab loam, 2 to 4 percent slopes |
| LaC | Linoyer very fine sandy loam, 2 to 5 percent slopes |
| MaB | Manassa silt loam, 0 to 2 percent slopes |
| Mg | Mellor silt loam |
| MoC | Mountainville very stony sandy loam, 3 to 10 percent slopes |
| SfC | Shabliss very fine sandy loam, 2 to 5 percent slopes |
| TdB | Thiokol silt loam, dry, 0 to 2 percent slopes |
| WaB | Wales loam, 2 to 4 percent slopes |
| WbB | Wales loam, dry, 2 to 4 percent slopes |
| WfA | Woodrow silt loam, 0 to 1 percent slopes |
| WfB | Woodrow silt loam, 1 to 2 percent slopes |
| WfC | Woodrow silt loam, 2 to 5 percent slopes |

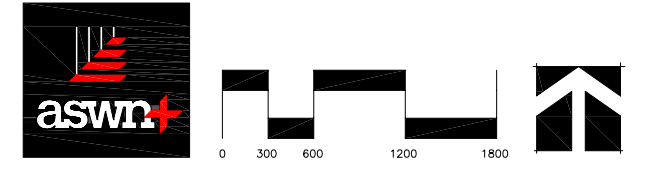

Soil Data

Exhibit 13.7



Public Safety Facility

Station Access

Parking Area

**ATV Loading/
Trailhead**

Phase 1
Approx 1.5 Acres

Existing
White Hills
Subdivision

Soccer Field

Play

Pavilion

ATV Trail Access

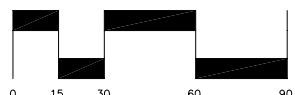

White Hills Park

Exhibit 13.8

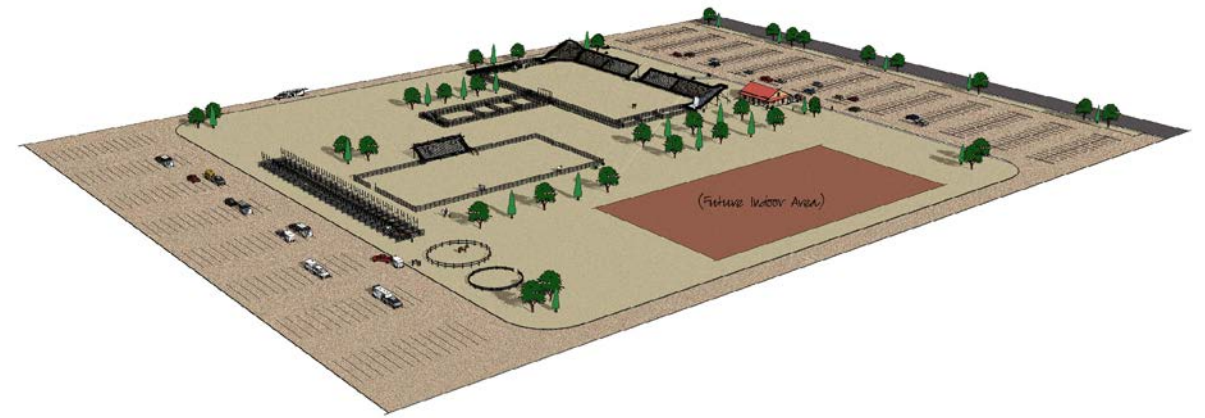
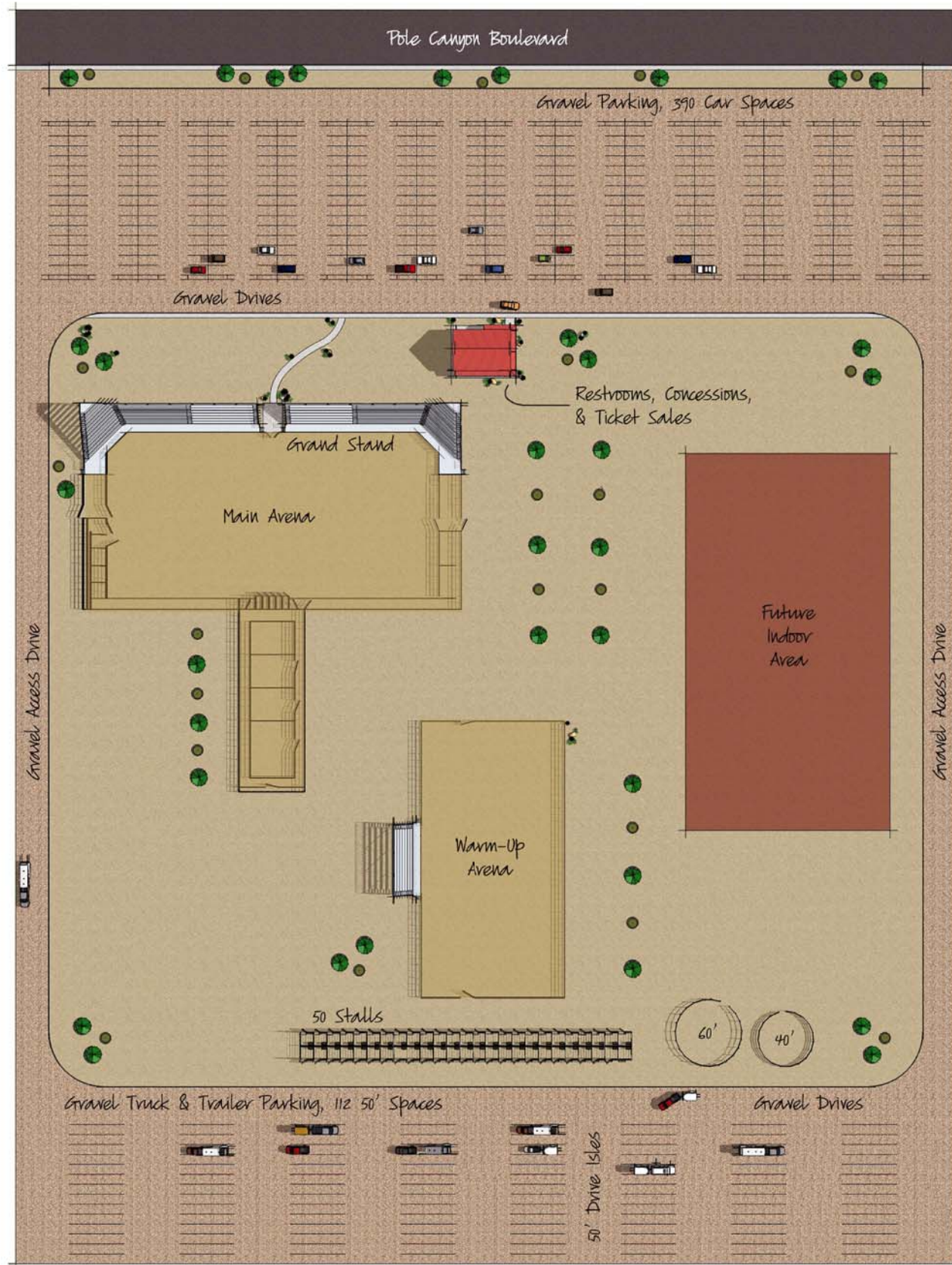

Eagle Mountain Rodeo Grounds at Pole Canyon

Exhibit 13.9



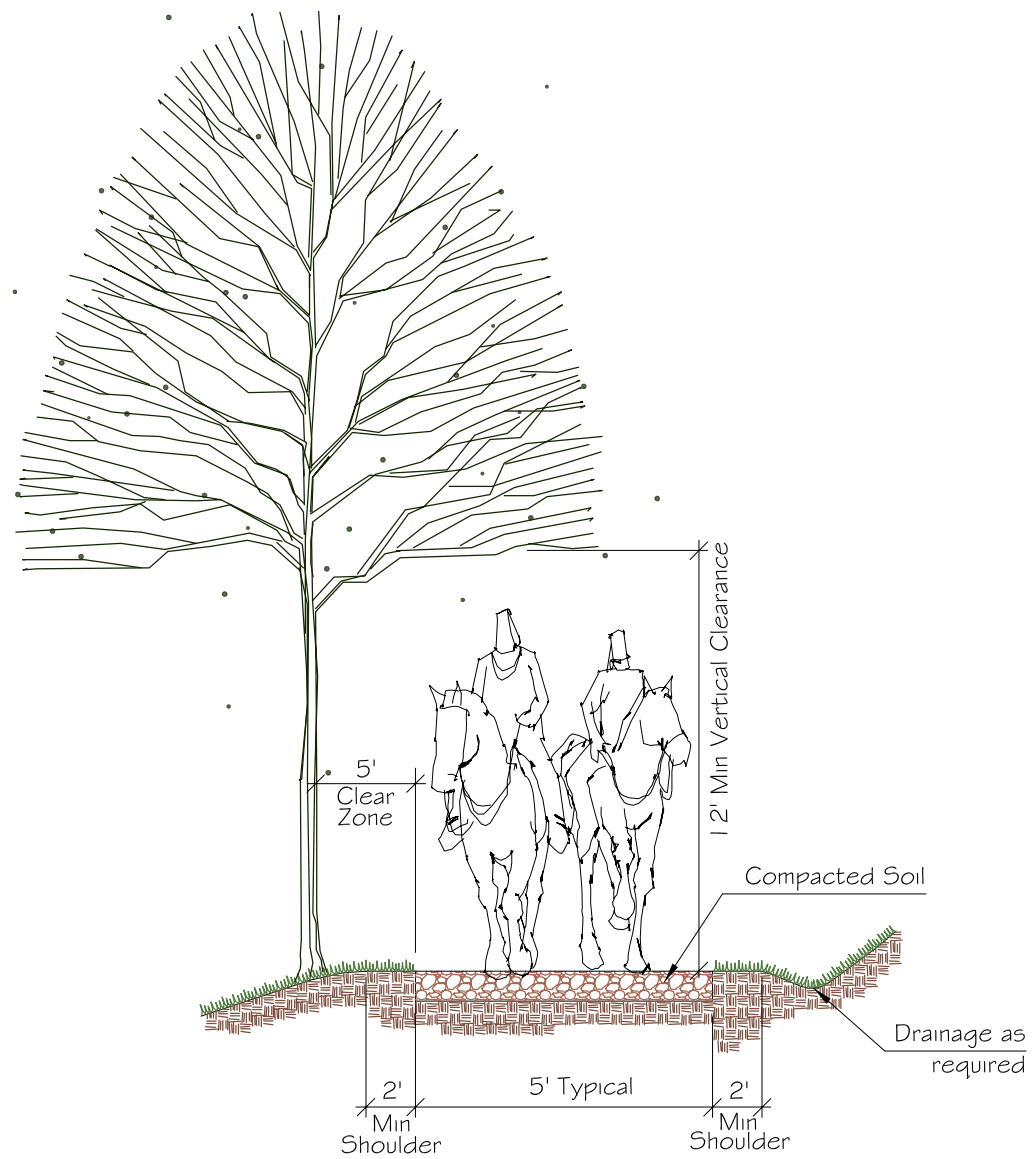

Off-road Equestrian Trail

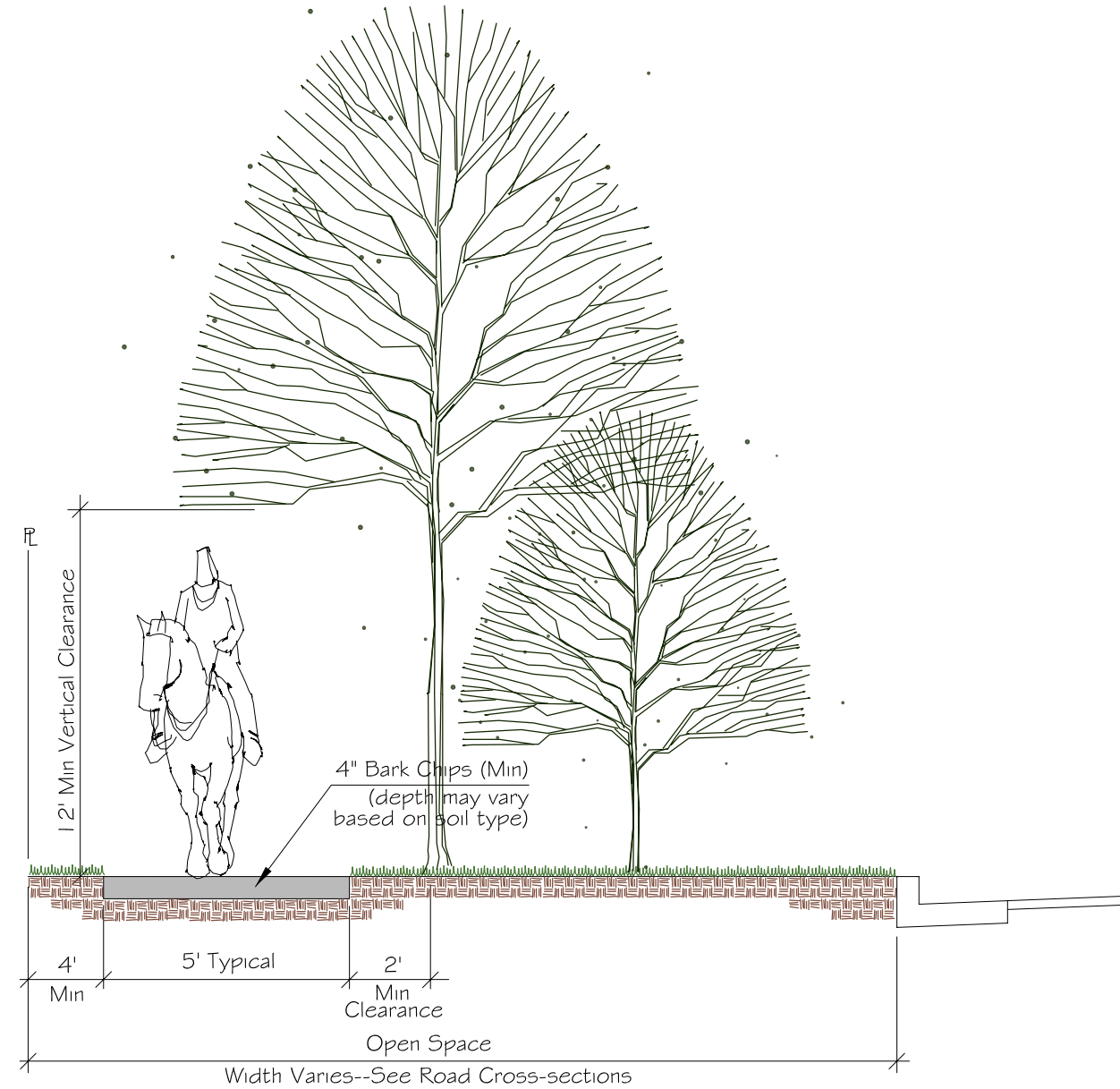

Roadway Equestrian Trail

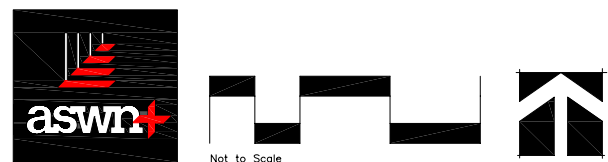

**Equestrian Trail
Cross-sections
Exhibit 13.10**



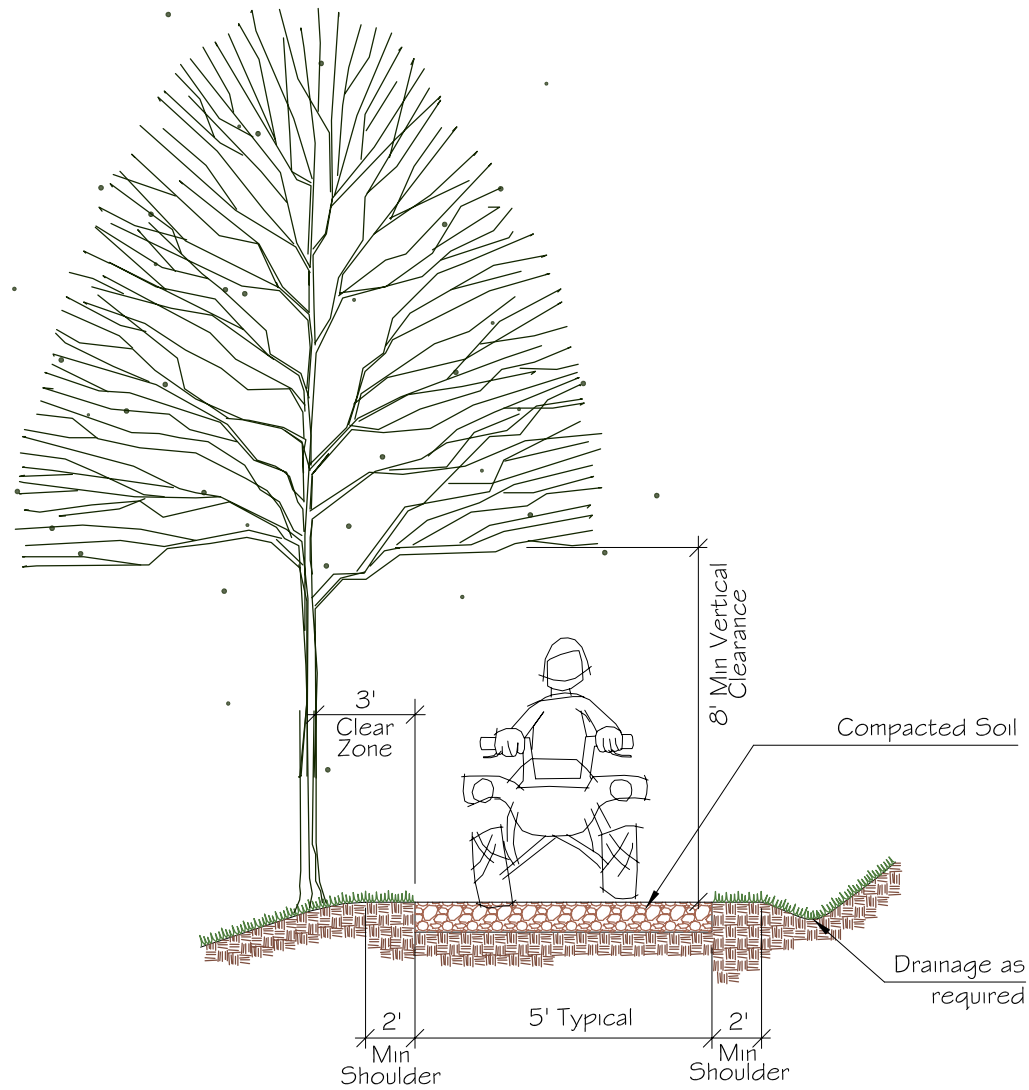

Off-road ATV Trail

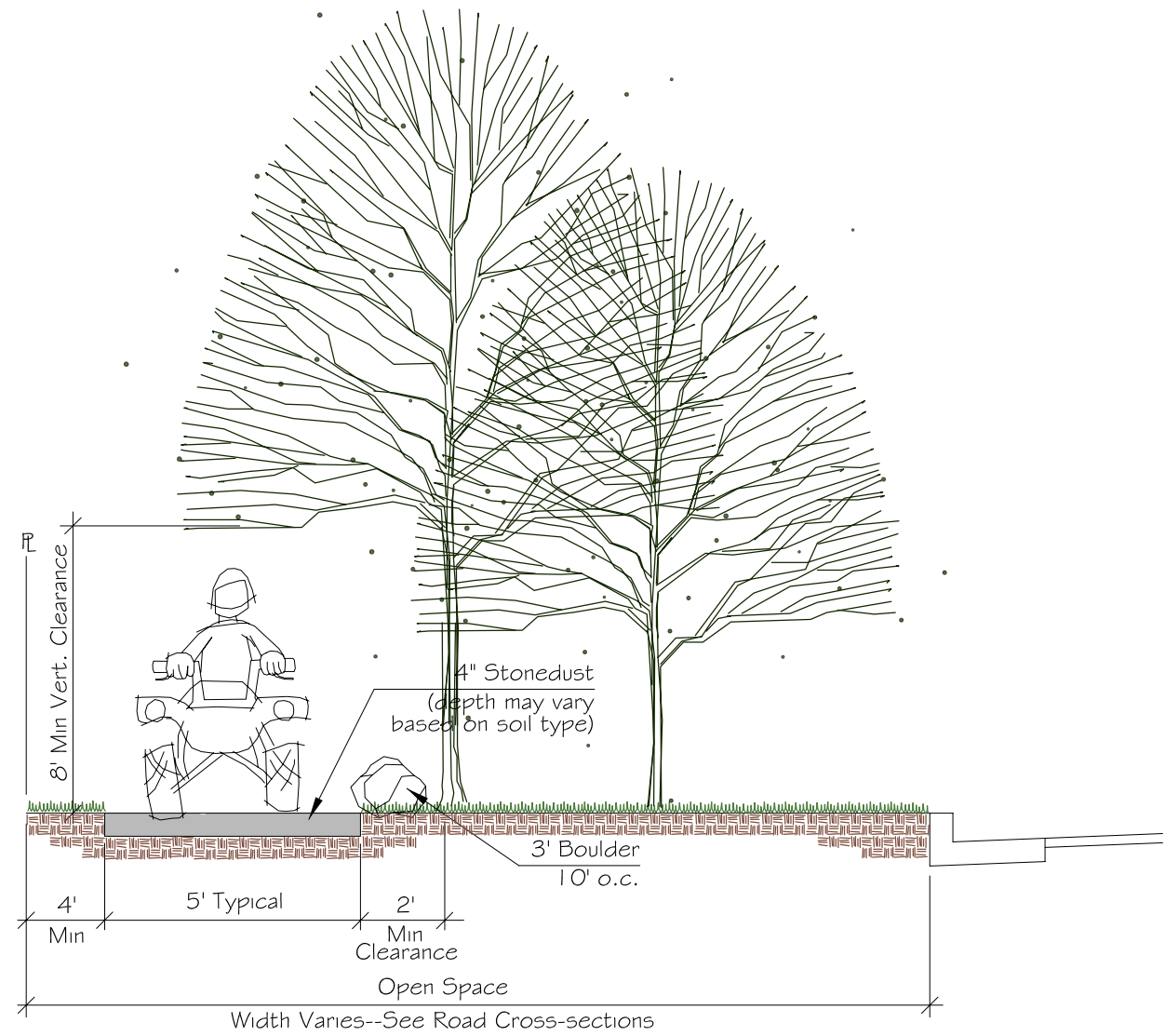

Roadway ATV Trail



**ATV Trail
Cross-sections
Exhibit 13.11**



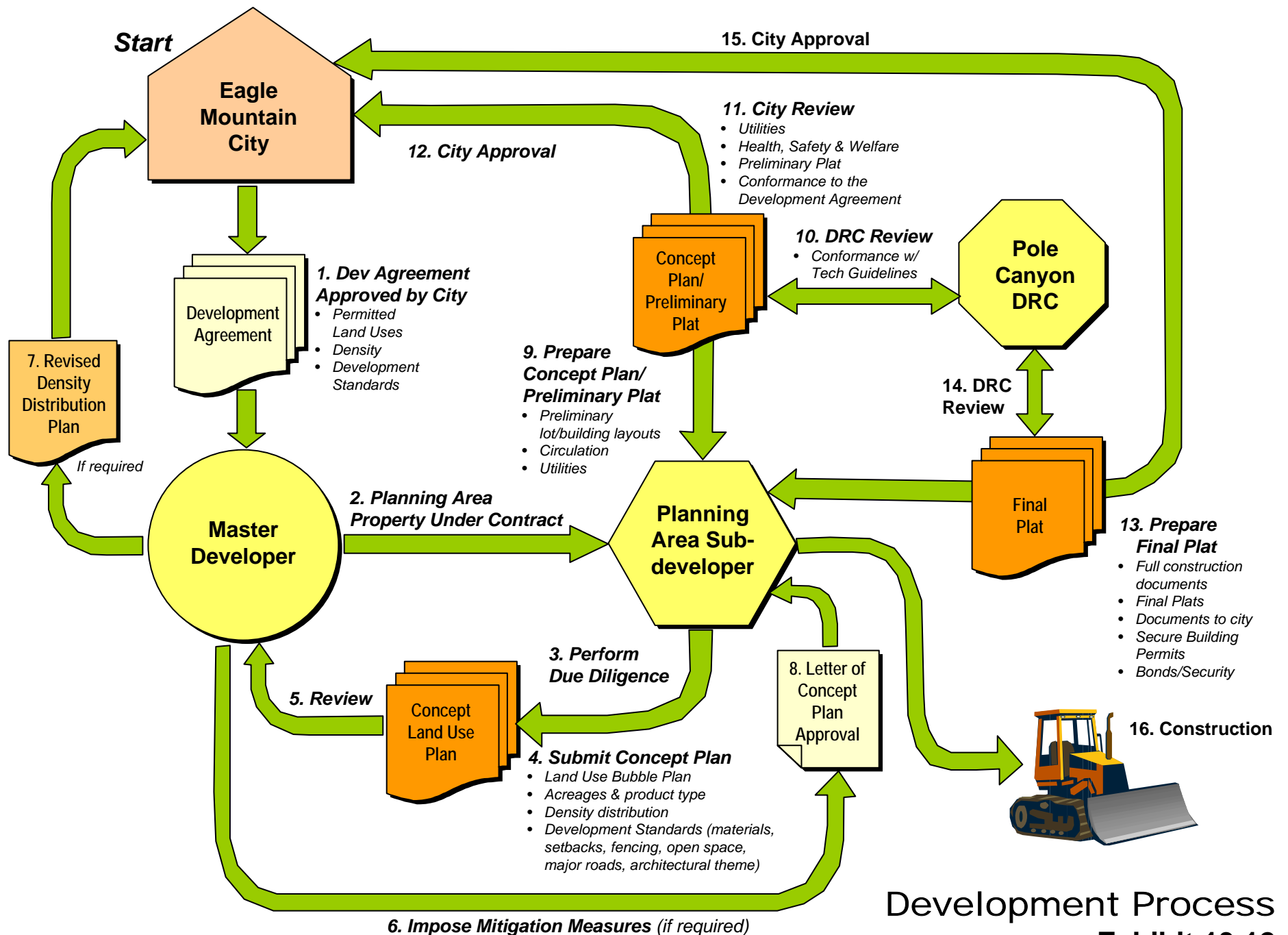

Development Process
Exhibit 13.12

Exhibit 14 – Short-Form Notice of Agreement

WHEN RECORDED RETURN TO:

Oquirrh Wood Ranch, LLC
Attention: Nathan D. Shipp
1099 West South Jordan Parkway
South Jordan, Utah 84095

MEMORANDUM OF POLE CANYON ANNEXATION AND
MASTER DEVELOPMENT AGREEMENT

THIS MEMORANDUM OF POLE CANYON ANNEXATION AND MASTER DEVELOPMENT AGREEMENT ("Memorandum") is made and entered into effective as of the ____ day of December, 2009, by and between EAGLE MOUNTAIN CITY, a Utah municipal corporation (the "City"), and those certain undersigned parties referred to herein as the "Pole Canyon Investment Group" or "PCIG".

The PCIG and the City have entered into that certain "Pole Canyon Annexation and Master Development Agreement" dated as of the ____ day of December, 2009 (the "Agreement"), regarding the real property commonly known as "Pole Canyon," which property is more particularly described on Exhibit A attached hereto. Copies of the Agreement are on file in the offices of the City of Eagle Mountain.

This Memorandum is executed and recorded in the Utah County Recorder's Office in order to provide third parties with notice of the Agreement.

[Remainder of Page Intentionally Left Blank.]

IN WITNESS WHEREOF, the parties have executed this Memorandum by their authorized representatives effective as of the date first written above.

CITY:

EAGLE MOUNTAIN CITY, a Utah
municipal corporation

ATTEST:

By: _____
Heather Jackson, Mayor

By: _____
City Clerk

POLE CANYON INVESTMENT GROUP:

OQUIRRH WOOD RANCH, LLC, a Utah
limited liability company

GSJFJV, LLC, a Utah limited liability company

By: Shipp Ventures, Inc., a Utah
corporation, its Manager

By: OQUIRRH WOOD RANCH, LLC, a Utah
limited liability company, its Manager

By: Shipp Ventures, Inc., a Utah
corporation, its Manager

By: _____
Nathan D. Shipp, President

By: _____
Nathan D. Shipp, President

STATE OF UTAH)
 : ss.
COUNTY OF _____)

On _____, 20____, before me, _____, a Notary Public personally appeared Mayor Heather Jackson, personally known to me (or proved to me on the basis of satisfactory evidence) to be the person whose name is subscribed to the within instrument and acknowledged to me that she executed the same in her authorized capacity, and that by her signature on the instrument the person, or the entity upon behalf of which the person acted, executed the instrument.

WITNESS my hand and official seal.

Signature _____(Seal)

STATE OF UTAH)
 : ss.
COUNTY OF _____)

On _____, 20____, before me, _____, a Notary Public personally appeared Nathan D. Shipp, personally known to me (or proved to me on the basis of satisfactory evidence) to be the person whose name is subscribed to the within instrument and acknowledged to me that he executed the same in his authorized capacity, and that by his signature on the instrument the person, or the entity upon behalf of which the person acted, executed the instrument.

WITNESS my hand and official seal.

Signature _____(Seal)

STATE OF UTAH)
 : ss.
COUNTY OF _____)

On _____, 20____, before me, _____, a Notary Public personally appeared Nathan D. Shipp, personally known to me (or proved to me on the basis of satisfactory evidence) to be the person whose name is subscribed to the within instrument and acknowledged to me that he executed the same in his authorized capacity, and that by his signature on the instrument the person, or the entity upon behalf of which the person acted, executed the instrument.

WITNESS my hand and official seal.

Signature _____(Seal)

1061074

EXHIBIT A

PROPERTY DESCRIPTION

[TO BE ATTACHED.]